

134

168

# Dispersed, Decentralized and Renewable Energy Sources:

## Alternatives to National Vulnerability and War

Energy and Defense Project

FEMA WORK UNIT #2314-F

DCPA 01-79-C-0320

Final Report

December 1980

APPROVED FOR PUBLIC RELEASE: DISTRIBUTION UNLIMITED

134

168

DISPERSED, DECENTRALIZED AND RENEWABLE  
ENERGY SOURCES:  
ALTERNATIVES TO NATIONAL VULNERABILITY AND WAR

FINAL REPORT

BY

THE ENERGY AND DEFENSE PROJECT

FOR

FEDERAL EMERGENCY MANAGEMENT AGENCY  
WASHINGTON, D.C. 20472

Contract DCPA 01-79-C-0320  
FEMA Work Unit #2314-F

DECEMBER 1980

FEMA REVIEW NOTICE:

"This report has been reviewed in the Federal Emergency Management Agency and approved for publication. Approval does not signify that the contents necessarily reflect the views and policies of the Federal Emergency Management Agency."

APPROVED FOR PUBLIC RELEASE: DISTRIBUTION UNLIMITED



DISPERSED, DECENTRALIZED AND RENEWABLE  
ENERGY SOURCES:  
ALTERNATIVES TO NATIONAL VULNERABILITY AND WAR

Executive Summary

The Problem

U.S. reliance on imported fuel and centralized systems for energy production present problems for national security and emergency preparedness in the event of a major nuclear crisis or war. Energy supply and demand planning should be linked to civil defense planning in order to decrease vulnerability and maximize survival and recovery capabilities. The development of alternative energy systems such as cogeneration, wind, biomass, solar, small hydro, and the like can reduce U.S. dependence on imported fuels and strategic materials and thus vulnerability to disruptions in those supplies. Renewable and dispersed energy systems for fuel and electricity offer the best potential for survival and recovery if implemented at the local level.

To explore the ramifications of this situation, the Federal Emergency Management Agency has funded the present study to examine the use of unconventional energy sources and alternative approaches to vulnerable centralized energy supply systems.

Objectives

The objectives of this study were as follows:

1. To investigate, review and categorize alternative approaches to centralized energy supplies which are vulnerable and could be considerably affected by enemy attack.
2. To survey a number of alternative, renewable energy systems and to provide a treatment of the technical, applied, developmental, and cost factors related to these energy technologies and their potential for localized energy self-sufficiency.
3. To examine the use of present centralized energy technologies and to investigate the possibilities of simplification in design and operation in order to permit independent local operation.
4. To investigate strategies for sufficiency, storage, communications and planning for community survival and recovery based on renewable energy resources.

## Procedure

The procedures followed were:

1. Background information on centralized energy systems, national vulnerability due to dependence on imported fuels and centralized energy production, and the relationships between energy planning and existing civil defense programs was extensively researched, characterized and reported.
2. Alternative energy resources and systems, including conservation, load management and energy storage, cogeneration, fuel cells, small hydroelectric power, solar/heating, solar/thermal electric, solar photovoltaic, biomass conversion, geothermal, wind, and wave energy were identified and ranked in terms of their technological characteristics, developmental factors, their strategic capabilities (to reduce vulnerability), local and regional availability, current and projected costs, and overall flexibility to meet current and potential post-attack energy demands.
3. Matrices for evaluation of these technologies by local and emergency planners were provided, with qualitative criteria for their development.
4. Strategies for energy sufficiency and planning for community survival and recovery were provided which outline the concept of the "Defense Energy Districts" (DEDs).
5. Specific recommendations for the use of localized energy approaches for emergency response and recovery based on Project findings were provided.

## Major Findings

The major findings of the report are:

1. Current U.S. energy systems (fuels and electricity) are highly vulnerable, due to requirements for imported resources and due to the centralized nature of the systems themselves.
2. Dispersed, decentralized and renewable energy sources can reduce national vulnerability and the likelihood of war by substituting for vulnerable centralized resources.
3. National policies and goals need to be developed to strengthen current inadequate energy emergency contingency planning and incorporate decentralized and renewable energy supplies into those plans.
4. Local policies and goals need to be developed to implement the range of programs described in the concept of the Defense Energy District.

5. National energy self-sufficiency programs (including synfuel development and Strategic Petroleum Reserve) are highly centralized, thus highly vulnerable. A better strategic opportunity is the development of dispersed local and regional approaches.
6. Current funding levels (both private and public) for decentralized and renewable energy are inadequate. National priorities should reflect the strategic value and importance of the decentralist/renewable energy opportunity.

## FOREWORD

Section 1, Energy and Vulnerability and Section 2, Energy: Existing Systems and Trends characterize the nation's energy vulnerability in terms of our dependence on imported energy supplies and strategic materials and in terms of the centralized nature of U.S. energy systems. The effects of supply disruptions and hostile actions, ranging from terrorist attacks and sabotage, to a nuclear crisis or war can be prevented or mitigated by strategies which promote energy supply independence by developing domestic, renewable resources, and by emphasizing smaller, dispersed and community-based energy production and distribution systems.

Section 3, Dispersed and Renewable Energy Systems provides a detailed technical treatment of a number of alternative energy technologies which can contribute to national energy security by shifting responsibility to the regional and community level for development and utilization of domestic energy resources. The alternatives range from conventionally fueled cogeneration projects to construction of facilities fueled by renewable resources such as solar, wind, biomass, etc.

The instability inherent in foreign-import dependence and system centralization can be considered a precursor to conflict and war. In the long run, full-scale development of dispersed and renewable energy systems to achieve local and regional self-sufficiency can contribute to a stronger, more secure national economy.

Section 4, Dispersed Energy Sources and Community Survival outlines specific strategies for combining civil defense planning with energy resource development for community self-sufficiency and survival.

## TABLE OF CONTENTS

### SECTION 1 - ENERGY AND VULNERABILITY

	<u>Page</u>
Introduction and Overview (1.1) . . . . .	1
Strategic Materials and Vulnerability (1.2) . . . . .	5
Centralization of Energy Systems and Vulnerability (1.3) . . . . .	10
Terrorism and Vulnerability (1.4) . . . . .	14
Natural Disasters and Vulnerability (1.5) . . . . .	17
Energy and War: Historical Lessons (1.6) . . . . .	19
Nuclear Weapons and Their Effects (1.7) . . . . .	30
Defense Preparedness and Vulnerability (1.8) . . . . .	37
Conclusions . . . . .	50
Footnotes . . . . .	51

### SECTION 2 - ENERGY: EXISTING SYSTEMS AND TRENDS

Introduction and Overview (2.1) . . . . .	59
Conventional Energy Systems (2.2) . . . . .	63
Energy Distribution Systems (2.3) . . . . .	90
Factors Influencing Centralization (2.4) . . . . .	92
Centralized Alternatives: Synthetic Fuels (2.5) . . . . .	97
Forecasting Electricity (2.6) . . . . .	113
Energy Systems and Economies of Scale (2.7) . . . . .	114
The Trend to Small Power Plants (2.8) . . . . .	120
Footnotes . . . . .	125

### SECTION 3 - DISPERSED AND RENEWABLE ENERGY SYSTEMS

Introduction and Overview (3.1) . . . . .	137
Energy Conservaton (3.2) . . . . .	139
Load Management and Energy Storage (3.3) . . . . .	153
Cogeneration (3.4) . . . . .	162
Fuel Cells (3.5) . . . . .	174
Small Hydroelectric Power (3.6) . . . . .	178
Solar Heating and Cooling (3.7) . . . . .	185
Solar Thermal Electricity (3.8) . . . . .	196
Ocean Thermal Energy Conversion (OTEC)(3.9) . . . . .	203
Solar Photovoltaics (3.10) . . . . .	207
Biomass Energy (3.11) . . . . .	216
Geothermal Energy (3.12) . . . . .	234
Wind Energy (3.13) . . . . .	245
Wave Energy (3.14) . . . . .	266
Conclusions (3.15) . . . . .	270
Footnotes . . . . .	275

### SECTION 4 - DISPERSED ENERGY SOURCES AND COMMUNITY SURVIVAL

Introduction and Overview (4.1) . . . . .	293
Community Survival and Recovery: Background (4.2) . . . . .	297
Selection of Alternative Fuels and Electric Power Sources (4.3) . . . . .	307
Conclusions and Recommendations (4.4) . . . . .	319
Footnotes . . . . .	325

---

BY THE COMPTROLLER GENERAL

# Report To The Congress

OF THE UNITED STATES

---

## Federal Electrical Emergency Preparedness Is Inadequate

If saboteurs, terrorists, or an enemy attacked the Nation's electric power system, would the Federal Government be prepared to handle the resulting energy disruptions?

Probably not, because the Department of Energy has failed to prepare required electric emergency preparedness plans. A national plan to cope with the problems caused by a loss of electricity--which would virtually halt communication, transportation, and distribution systems--is essential, because utilities and the States cannot be expected to deal with such emergencies on their own.

The Department of Energy should work with the utility industry, the States, and the Federal Emergency Management Agency to develop and maintain detailed electrical emergency plans.



EMD-81-50  
MAY 12, 1981



Request for copies of GAO reports should be sent to:

U.S. General Accounting Office  
Document Handling and Information  
Services Facility  
P.O. Box 6015  
Gaithersburg, Md. 20760

Telephone (202) 275-6241

The first five copies of individual reports are free of charge. Additional copies of bound audit reports are \$3.25 each. Additional copies of unbound report (i.e., letter reports) and most other publications are \$1.00 each. There will be a 25% discount on all orders for 100 or more copies mailed to a single address. Sales orders must be prepaid on a cash, check, or money order basis. Check should be made out to the "Superintendent of Documents".



COMPTROLLER GENERAL OF THE UNITED STATES  
WASHINGTON D.C. 20548

B- 200596

To the President of the Senate and the  
Speaker of the House of Representatives

This report discusses the vulnerability of the Nation's electric power systems to disruptions from acts of war, sabotage, and terrorism and analyzes the Federal rôle in dealing with major, long-term electrical emergencies resulting from such acts.

We made this review because of the importance of electricity to the Nation, to inform the Congress of the adequacy of Federal electrical emergency preparedness and planning, and to recommend improvements.

Copies of this report are being sent to the Director, Office of Management and Budget, the Secretary of Energy, Director of the Federal Emergency Management Agency and the House and Senate committees and subcommittees having oversight responsibilities for the matters discussed in the report.

A handwritten signature in cursive script that reads "Shelton J. Arosler".

Acting Comptroller General  
of the United States



COMPTROLLER GENERAL'S  
REPORT TO THE CONGRESS

FEDERAL ELECTRICAL  
EMERGENCY PREPAREDNESS  
IS INADEQUATE

D I G E S T

The Federal Government is not now prepared to handle a long-term national or regional disruption in electric power, from an act of war, sabotage, or terrorism. Inadequate preparedness for such emergencies is not new. About 3 years ago, the Congress found that Federal programs dealing with electrical power emergencies were deficient.

The consequences of such a power outage are staggering. Electric power is essential to maintaining the Nation's military readiness. Without adequate or reliable power, most industrial activity would be disrupted. Power outages can disrupt the operation of computers, commercial business, water and sewage treatment plants, mass transit and traffic control systems, as well as many other aspects of life.

In the United States, electric power is generated by some 3,500 utility companies, sent over thousands of miles of high voltage transmission lines, and distributed over low voltage feeder lines to end users. The system is a highly complex, interconnected industry network covering the United States and parts of Canada.

Electric power systems are highly dependable, but are very vulnerable to disruptions from acts of war, sabotage, or terrorism. In the region GAO looked at:

- An attack on just eight substations could disrupt power to the entire region for a long time. (See p. 8.)
- Damage to just four substations could disrupt power to one city for up to a year. (See p. 8.)
- Damage to just one substation could leave a key military facility without power. (See p. 8.)

Because of the complexity of the Nation's electric system, it is essential that the Federal Government play a central role in emergency planning. The Department of Energy is responsible for preparing national emergency plans and preparedness programs covering electrical power generation, transmission, distribution, and utilization. The Federal Emergency Management Agency is responsible for setting policy and coordinating all civil defense and emergency planning, mitigation, and assistance functions.

Federal leadership for electrical emergency planning and preparation is unorganized and ineffective. GAO found:

- DOE has an inadequate program for dealing with major electrical disruptions. In fact, its Emergency Electric Power Administration, tasked with these responsibilities, is insufficiently staffed and widely decentralized. "Barely alive" is how one official described the organization. (See p. 13.)
- Emergency Electric Power Administration representatives are unsure of their status, roles, authority, and responsibility, and they are doubtful that the organization could operate during an emergency. (See pp. 13 and 14.)
- DOE does not have adequate plans to manage and mitigate electric power disruptions. (See pp. 15 and 16.)
- Emergency plans to manage such disruptions and restore the power system, are needed. (See pp. 16 to 18.)
- Problems exist in Federal coordination with respect to electric emergency preparedness. (See pp. 18 and 19.)

Because of the severe consequences of electric power disruptions, the Government must be concerned with the management and recovery of the Nation's power system during major emergencies resulting from war, sabotage, or terrorism. It is essential that electric emergency plans be developed beforehand so they can be quickly activated to allow officials to make difficult decisions in the midst of confusion. Once an electric emergency occurs, it will be too late

to make preparations. Without prior planning, the Government will be deprived of the benefit of prudent thought and study.

RECOMMENDATIONS TO THE  
SECRETARY OF ENERGY

The Secretary of Energy should carry out his responsibility for electrical emergency preparedness by

- providing adequate resources to the Emergency Electric Power Administration,
- acting as leader and working with the utility industry, other Federal agencies and States to develop and maintain detailed electrical emergency plans, and
- developing national/regional plans for electrical emergencies which will (1) enable power disruptions to be managed through established priorities for curtailing power by use and type of customer and (2) assist the utility industry in restoring power in the event of severe damage to the electric power system.  
(See p. 22.)

RECOMMENDATIONS TO THE  
DIRECTOR OF THE FEDERAL  
EMERGENCY MANAGEMENT AGENCY

The Director of the Federal Emergency Management Agency should

- actively monitor DOE's efforts to vitalize its emergency electric power program and develop associated plans,
- require progress reports from DOE, and
- actively assist, support, and coordinate DOE's efforts especially with respect to other Federal agencies.  
(See p. 23.)

RECOMMENDATIONS  
TO THE CONGRESS

Inadequacies in electrical emergency preparedness have not been corrected after 3 years. If DOE's comments on this

report indicate it will not develop national/regional plans for electrical emergencies, then GAO recommends that the Congress enact legislation requiring that appropriate plans be developed by a specified date. (See p. 23.)

#### AGENCY COMMENTS

GAO provided copies of the draft of this report to the National Electric Reliability Council, the Federal Emergency Management Agency, and DOE. The National Electric Reliability Council and the Federal Emergency Management Agency agreed with the report's recommendations. DOE, however, said that the report fails to distinguish between non-defense and defense related emergencies, and therefore, is misleading. GAO disagrees with this contention because the report addresses electrical emergencies which have national impact and reflects the status of DOE's efforts as required under legislation and Executive order. (See pp. 23 to 27.)

## C o n t e n t s

	<u>Page</u>
DIGEST	i
CHAPTER	
1 INTRODUCTION	1
Need for Federal electrical emergency preparedness	1
Objectives, scope, and methodology	1
2 ELECTRIC POWER SYSTEM	4
Economic importance	4
The electric power system	6
Power systems are highly vulnerable	8
An electric emergency scenario	8
Consequences to the power system	9
Regional and national consequences	9
Consequences of disruptions can be mitigated	10
3 THE FEDERAL GOVERNMENT IS NOT PREPARED TO DEAL WITH ELECTRICAL EMERGENCIES	12
Federal responsibility for electrical emergencies	12
Electrical emergency preparedness program is inadequate	13
No comprehensive electrical emergency plans	15
Emergency plans are needed	16
Plans to manage disruptions	16
Plans to restore the power system	17
Lack of Federal coordination and guidance	18
4 CONCLUSIONS AND RECOMMENDATIONS	20
Conclusions	20
Recommendations to the Secretary of Energy	22
Recommendations to the Director of the Federal Emergency Management Agency	23
Recommendations to the Congress	23
Agency comments and our evaluation	23
National Electric Reliability Council	23
Federal Emergency Management Agency	24
Department of Energy	24
APPENDIX	
I National Electric Reliability Council's Comments	28
II Federal Emergency Management Agency's Comments	31
III Department of Energy's Comments	33

ABBREVIATIONS

DOE	Department of Energy
DOD	Department of Defense
EEPA	Emergency Electric Power Administration
FEMA	Federal Emergency Management Agency
GAO	General Accounting Office
NERC	National Electric Reliability Council



## GLOSSARY

Blackout	The disconnection of the source of electricity from all electrical loads in a certain geographical area brought about by insufficient generation, an emergency-forced outage, or other fault in the generation/transmission/distribution system servicing the area.
Cascading blackout	A specific type of blackout in which a system component failure compounds into other system component failures and results in the disconnection of the source of electricity from all loads in a geographical area.
Generation	The act or process of producing electric energy from other forms of energy, also the amount of electric energy provided.
Interconnected system	A system consisting of two or more individual power systems normally operating with connecting tie lines.
Load	The amount of electric power delivered to a given point on a system.
Megawatts	The electric unit of power which equals 1,000,000 watts or 1,000 kilowatts.
Outage	In a power system, the state of a component (such as a generating unit or a transmission line) when it is not available to perform its function due to some event directly associated with the component.
Power	The time rate of transferring or transforming energy; for electricity, expressed in watts. Power, in contrast to energy, always designates a definite quantity at a given time.
Rotating blackout	A blackout caused by intentional rotational load drops in a particular area.
Spinning reserve	A reserve generating capacity ready to take an immediate load.
Substation	An electrical power station without generation which serves as a control and transfer point on an electric transmission system.

**Transformer** A device for transferring energy from one circuit to another in an alternating-current system.

**Transmission** In power system usage, the bulk transport of electricity from large generation centers over significant distances to interchanges with large industries and distribution networks of utilities.

**Volt** The unit of electromotive force or electric pressure analogous to water pressure in pounds per square inch. It is the electromotive force which, if steadily applied to a circuit having a resistance of 1 ohm, will produce current of 1 ampere.

**Wheeling** The use of transmission facilities of one system to transmit power of and for another system.



## CHAPTER 1

### INTRODUCTION

Electric power is vital to our Nation's economic and social well being. Without electricity industries could not function, communications would be greatly reduced, and the welfare of our citizens greatly threatened. In this report we look at how prepared the United States is to deal with unusual and unexpected power outages caused by war, sabotage, or terrorism and suggest a meaningful approach to Federal preparedness for such electric emergencies.

#### NEED FOR FEDERAL ELECTRICAL EMERGENCY PREPAREDNESS

If the Nation or a region suffers a major, long-term power disruption caused by war, sabotage, or terrorism, the consequences would most likely have national impact. Neither utilities nor State/local governments can reasonably be expected to effectively manage such situations because such entities cannot reflect national needs. Consequently, any overall decisions at these levels cannot possibly serve the best interest of the Nation. For example, if an electrical system is seriously damaged, many areas served by that system could be without full service for extended periods. The utility which owns that system may be able to serve only limited customers and provide interruptible service. At that point, decisions would have to be made regarding who would get power and which elements of the system should be repaired first. The implications of these decisions could have widespread social, economic, legal, and defense-related consequences if the affected area crosses jurisdictional boundaries and the system damage was extensive. Consequently, the Federal Government because of its overall interests and resources is in the best position to prepare for and manage such disruptions.

While it is true that the Nation's electrical systems have not experienced severe and major disruptions from such events, there is no assurance this won't happen. Being prepared for such unexpected emergencies with severe potential consequences is a function of Government. We learned that damage to just a few key facilities could result in regional power disruptions for extended periods of time with severe consequences.

#### OBJECTIVES, SCOPE, AND METHODOLOGY

Our objective was to evaluate Federal preparedness for effectively managing a national/regional electric power emergency resulting from war, sabotage, or terrorism. In evaluating Federal preparedness we (1) considered the importance of electricity and the effects of power disruptions on the Nation, (2) assessed the vulnerability of electric systems to disruptions, and (3) analyzed Federal agency roles, programs, and plans for dealing with electric

emergencies. We limited our analysis to electric emergencies which would result from war, sabotage, and terrorism. Oil disruptions which could result in electrical emergencies are being addressed as part of another GAO review.

For purposes of assessing Federal preparedness we defined an electrical emergency as a major power disruption which would

- have major national/regional impact;
- be beyond the utility industry's capability to manage on its own;
- be sudden, unusual, unexpected, and (most likely) prolonged; and
- be the subject of a declaration of national emergency.

Acts of sabotage, war, or terrorism would most likely result in such electrical power disruptions. Because the utility industry does not regularly plan for these events and cannot determine national needs, it cannot adequately deal with such emergencies. While the utility industry has demonstrated the capability to manage and restore service in most instances of power outages caused by accidents, weather, equipment failures, and human error, utility officials we contacted agreed they would have severe problems dealing with long-term power disruptions on their own.

Since there is no definition as to what constitutes a long-term disruption, we assumed for our study that such a disruption would last for several weeks or longer. While it is possible that a shorter term disruption could require Federal involvement in an emergency, we did not consider this issue.

Since the Nation has never experienced an electrical emergency, as defined, we looked at one specific region to gain a perspective of what could happen. We met with Government and industry officials to discuss the regional power system's vulnerabilities and how it could be disrupted, and assessed the potential consequences. From this information, we developed a scenario which highlights a possible emergency situation in one region. Because of the sensitive nature of such information, the specific region and the electric facilities within the region are not cited.

In assessing the vulnerability and the effects of potential power disruptions, we also relied on available studies. We accepted the findings of these studies as to the social and economic consequences that electric outages would have.

To determine who was legally responsible for managing electric emergencies, we reviewed applicable laws and executive orders.

We also identified agencies having programs in electricity management and determined how they viewed their respective roles. This effort included both the Federal and electric utility sector.

With respect to the Federal role, we focused on the adequacy of the Department of Energy's (DOE) and the Federal Emergency Management Agency's (FEMA) efforts and their ability to effectively manage and restore electric power in the event of prolonged and widespread power outages. We also looked at efforts to mitigate electrical emergencies as part of Federal preparedness for such emergencies. To provide a balanced perspective, we discussed Federal preparedness for electrical emergencies with both Government and private utility industry officials.

We identified and obtained existing Federal plans for emergency electric preparedness and evaluated the adequacy of existing plans. In doing this, we looked at plans to see if objectives, priorities, authority, and responsibilities were clearly delineated and defined. Also, we discussed emergency planning with both Government and industry officials to identify basic elements of sound electrical emergency planning.

We did not address the question of whether damage from acts of war, sabotage, or terrorism could be prevented or minimized. In our view there is no guarantee such damage can be prevented, and any determination on what can be done to protect the power system would require extensive resources to analyze each threat, assess potential damages, and consider possible and available preventive measures coupled with a detailed cost benefit analysis. Further, actions to prevent damage from these acts would be costly to implement, and it is not likely such efforts would be undertaken. Consequently, we focused our review effort on what could be done to manage and restore power if such events occurred.

## CHAPTER 2

### ELECTRIC POWER SYSTEM

The growth of our Nation has been aided by the electric power system--one of the most complex systems ever built by man. Because the electric power system is visible and extensive, it is highly vulnerable to long-term major disruptions resulting from war, sabotage, or terrorism. The consequences of such disruptions to portions of our electric power system could be serious.

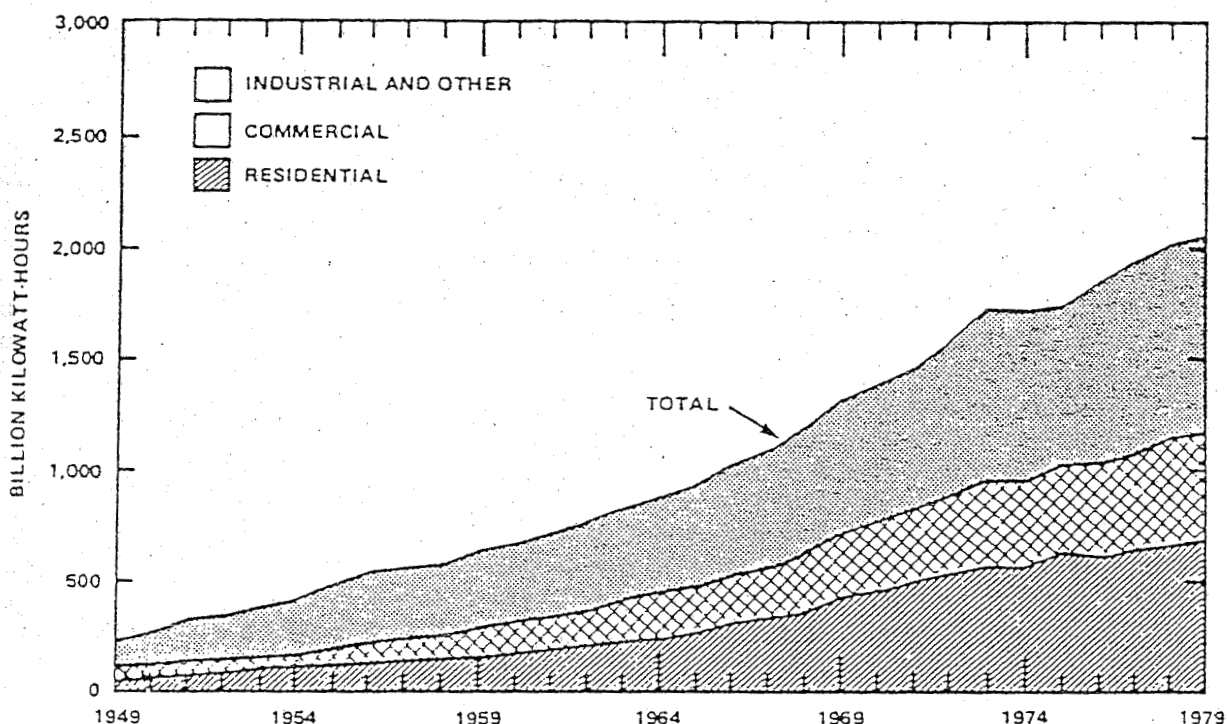
#### ECONOMIC IMPORTANCE

The electric power which the utility industry provides is the mainspring of our industrial economy. We as a Nation demand and expect this commodity to be continuously available. We do not, however, fully appreciate this energy source until "the lights go out." Without power everything in our modern society naturally grinds to a halt. For example, electricity is an integral component of our transportation, communication, and distribution systems. Manufacturing and food production rely heavily on electricity, and the American standard of living is tied to the use of electrical energy. Electric power is indispensable to maintaining our Nation's military readiness and running our

- defense industry;
- gasoline refineries and stations;
- manufacturing plants;
- computer systems;
- hospitals, office buildings, and airports;
- water and sewage treatment plants;
- mass transit and traffic control systems; and
- home heating, lighting, and cooking.

About 30 percent of the Nation's energy requirements is provided by electricity. Figure 1 shows that over the period 1949 to 1979 electric consumption increased by about 900 percent in the residential and commercial sectors and by about 500 percent in the industrial sector.

FIGURE 1  
SALES OF ELECTRICITY BY END-USE SECTOR



Source: DOE

An inadequate or unreliable source of power can have many adverse effects. For most industries, a reliable source of power is essential because a power interruption would stop production. In many industries, overhead and labor costs continue to accrue during outages. Major losses can result from restart costs, cleanup costs, damage to machinery and equipment, and the rendering of a portion of the product unmarketable. Power outages could be particularly crippling to commercial operations. Commercial users who can be expected to suffer immediate and total disruption of their operation include department stores, restaurants, gasoline stations, sewage treatment plants, and recreation facilities. Some users who could probably continue operations on a limited level and at reduced efficiency during power outages include office buildings, banks, hospitals, and schools.

Power disruptions would also affect the public. Obvious consequences include

- potential for increased crime and loss of civil order due to darkness, lack of communication, and disabling of electric security alarms;



- increase in water pollution due to disruption of sewage treatment facilities;
- inconvenience and health hazard of the residential customer caused by interruption of electricity;
- accidents caused by unexpected darkness or by interruption of life-support systems at hospitals, although some facilities have standby generators; and
- psychological traumas from the effects of sudden interruption of electricity (such as being trapped in an elevator or a windowless room).

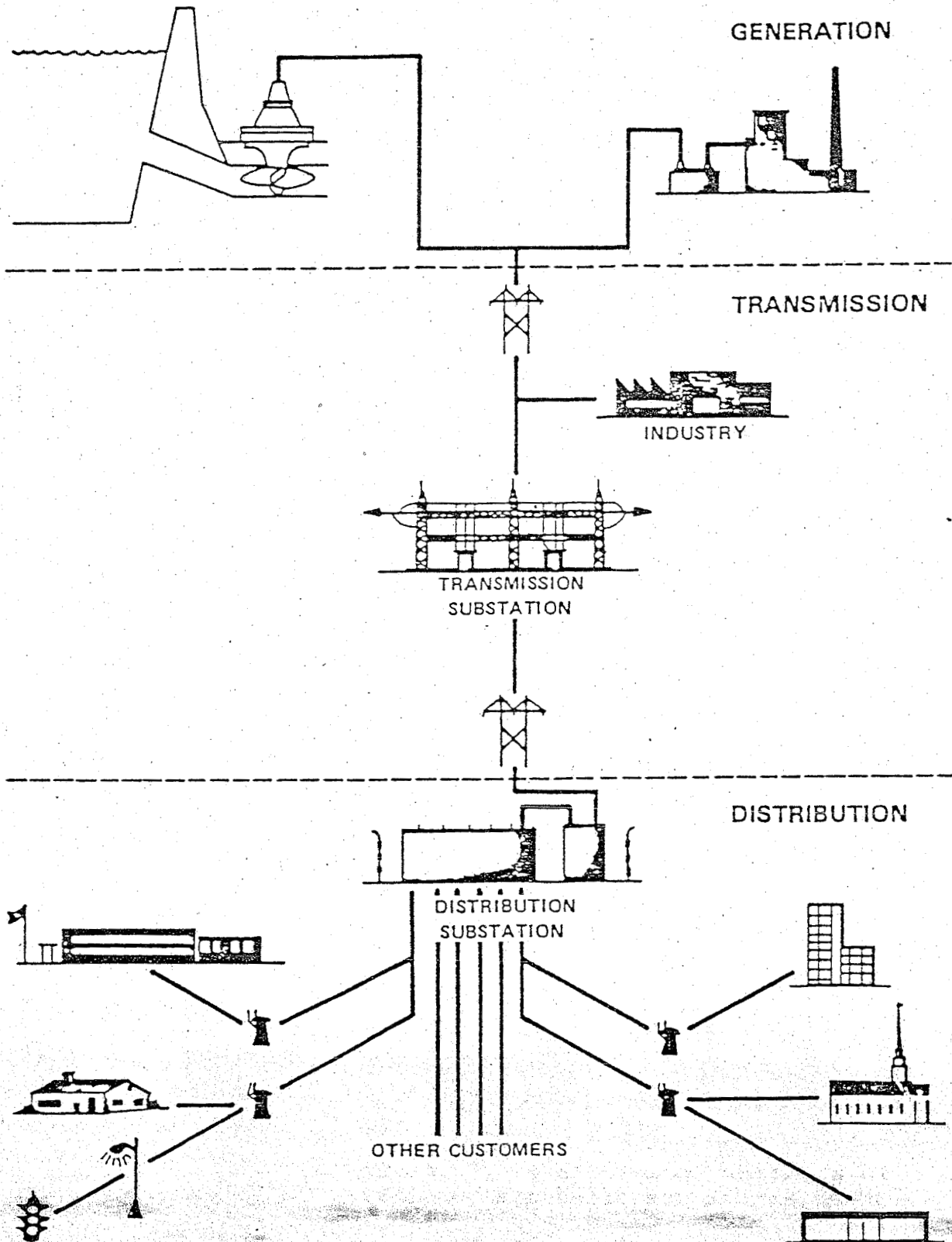
### THE ELECTRIC POWER SYSTEM

The Nation's existing bulk electric power supply system is very complex. At an elemental level, the supply of electricity to the ultimate consumer involves three steps: generation, transmission from the generator to the service area over high-voltage transmission lines, and distribution to individual end-users over low-voltage distribution lines as shown in figure 2. In total about 3,500 U.S. electric utility companies exist with about 557,000 megawatts of installed generating capacity. About 365,000 circuit miles of overhead electric lines of 66,000 volts or more transmit electricity from generation sources to utility service areas. In addition, countless miles of lower voltage distribution lines service 74 million residential, 8 million small light and power, and 700,000 large commercial and industrial customers.

Generally, a single electric utility provides power to a specified geographical area. While many utilities perform all three steps in supplying electric power, many others do not. Some utilities only distribute electricity by purchasing generation from other utilities, some rent the use of high-voltage transmission lines from other utilities in order to have electricity wheeled from the source of generation to their service area, and others are only in the generation and transmission business.

Today, nearly every major electric utility system is connected with neighboring systems to form interconnected networks. Presently, three huge interconnected networks blanket the contiguous United States and much of Canada. These systems are (1) the Eastern Interconnected System consisting of the Eastern two-thirds of the United States, and Eastern Canada, (2) the Texas Interconnected System consisting of most of the State of Texas, and (3) the Western Interconnected System consisting of the Western part of the contiguous United States and Canada.

FIGURE 2  
COMPONENTS OF ELECTRIC POWER SYSTEM



SOURCE: DOE

POWER SYSTEMS ARE  
HIGHLY VULNERABLE

Electric power systems are very dependable, but are vulnerable to damage from acts of war, sabotage, and terrorism. While the systems are designed and operated to provide for a reliable energy source, and under most conditions do, Government and industry officials we contacted concerning this issue acknowledged this vulnerability. Principal threats cited were damage resulting from war and sabotage. Recent studies prepared for the Army Corps of Engineers, DOE, and FEMA all note that electrical power systems are highly vulnerable. Officials at these agencies confirmed this finding and an investigation by a joint congressional committee following the 1977 New York blackout, caused by lightning, concluded electric utilities are highly complex and very vulnerable.

AN ELECTRICAL  
EMERGENCY SCENARIO

Fortunately, the United States has never encountered an attack on its electrical system. But to place in perspective how such an event could occur and its possible results, we looked at one specific geographic region of the United States. <sup>1/</sup> The region's power system we selected provides power to transportation, aircraft, ship, chemical, and primary metal industries, and services several major military facilities. The system is composed of numerous electric distributors, thousands of miles of bulk transmission lines, and hundreds of substations and generating plants.

In looking at this one region DOE officials, regional officials, and private sources stated that coordinated attacks directed by saboteurs or terrorists could disrupt the region's power system. Most of the power system is highly vulnerable because its components are widely dispersed, operated in a low manpower environment, have minimal security, and are highly interdependent. Since maps, power system publications, explosives, timing devices, and other equipment are readily available, it would be very easy for saboteurs to damage the substations by setting off explosives in a coordinated attack. An attack on just eight substations could result in widespread power outages, with cascading blackouts throughout the electrical grid. In addition, major metropolitan areas in the region could be without power for several days and be subject to rotating blackouts for over a year. Damage to four substations could actually place one city on interruptible power for up to a year. One substation's key components could be damaged using a rifle and leave an important defense-related facility without power.

In addition to attacks on the region's substations, we found that other attack scenarios are possible. To illustrate, trans-

---

<sup>1/</sup>Similar events could occur in any region of the United States.



mission lines and towers are numerous, widely dispersed, and remotely located. While damage to one line may not have an extended impact on the region's power systems, attacks directed at several major transmission lines and associated towers would cause large scale disruptions. The recent Utah blackout illustrates what can happen. In this case, two transmission lines were shorted out as a result of a fire. This unexpected contingency, coupled with other system problems, caused a loss of load, shut down generating plants, and resulted in a cascading blackout throughout the State and parts of two other States. It required about 12 hours to return the power system to normal even though no significant physical damage to the system occurred.

Outside of some old publications and studies on the effects of damage to the power system as a result of nuclear war, studies assessing and analyzing the consequences of physical damage to a regional power system or the Nation have not been done. Based on our discussion with utility industry and Government officials, review of available literature on electric power systems and our own observations, we are able to make some judgments on regional and national consequences.

#### Consequences to the power system

The effect of any power disruption to the region would depend on what facilities were damaged, to what extent, and other circumstances. If substations are severely damaged, it could take a long time to repair and restore power to normal levels. While specific repair times cannot be predicted, a perspective of the time it will take can be gained by looking at actual construction times. Substation expansions and small size substations normally take 3 to 6 months to construct. Large substations can take up to 12 months. Damage or destruction to many substations would take much longer to restore. Transformers, a key component of substations, are vital to the operations of electric power systems. These components most likely would be damaged from sabotage or terrorist attacks on substations. Lengthy power disruptions could result because utility companies do not, in view of their expense, inventory or stockpile many large transformers.

Destruction of transmission lines can also have severe effects. If a number of bulk transmission lines are damaged in remote locations, restoration of power could be difficult. Extensive damage to enough major lines could require some time to repair. For example, depending on the type of tower, even if all logistics are taken care of, it can take from 1 to 3 days to erect just one tower. Multiple damage on an organized basis has never occurred and most certainly could over tax utility resources.

#### Regional and national consequences

From a regional and national perspective, the consequences of an extended disruption to the region we reviewed would be significant.

An extended disruption of power would affect the operations of

- major military facilities,
- ship and aircraft industries,
- the transportation industry,
- the electrical equipment and supplies industry, and
- chemicals, primary metals, and wood product industries.

Further, the health, safety, and socio-economic security of the region's population would be affected by a shortage of power to operate homes, hospitals, and businesses. Excess power which normally could be exported may not be available and, consequently, could affect other regions. Power from other regions may have to be imported even though sufficient excess power may not be available.

Regardless of whether a long-term power shortage occurs because power resources are inadequate or demands are excessive, supply would be inadequate to meet demand. Such a condition goes beyond normal planning and would provoke power curtailment restrictions. Absent from but crucial to the invocation of power curtailments would be a generally accepted regional agreement on how to take such drastic steps to handle the situation. In the region we looked at, the 120 utilities by themselves are not in a position to deal with the equitable allocation of power due to their fragmented nature. Further, utilities have legal and financial responsibilities to provide power to customers. States in the region have statutes providing for some type of power curtailment. However, because power supply and distribution become an interstate matter, difficulties and conflicts with respect to equitable distribution would most likely occur.

The most difficult way of dealing with power curtailments would be by independent decisions, utility by utility, State by State. Inherent in an individual public utility action would be its utility responsibility to provide customers with power and the inequitable distribution of the available supply--not every utility in any given emergency would necessarily be short in its energy supply. Because of these problems, regional utilities might lobby for their own interests.

#### CONSEQUENCES OF DISRUPTIONS CAN BE MITIGATED

Despite the obvious vulnerability of the Nation's electric power system, much could be done through sound planning to mitigate and minimize the consequences of disruptions. Even in a nuclear war, the effects of disruption can be minimized. While little can be done to alleviate the effects of blast damage, a

nationwide blackout may possibly be avoided by placing the power system into a more secure state. For example, because of the effects of a nuclear war, the power system would break up into individual islands. Because these islands may not have within their area sufficient generation available to pick up the load (spinning reserve), the area could be disrupted without any actual physical damage. Before an attack, this possibility might be minimized by bringing extra generation units on line to increase spinning reserve and thus increase power system stability. In the remaining chapters of this report, we discuss what the Federal Government has done to prepare for these emergencies and what it should be doing.

## CHAPTER 3

### THE FEDERAL GOVERNMENT IS NOT PREPARED TO DEAL WITH ELECTRICAL EMERGENCIES

Although the Federal Government is responsible for national electric emergency planning, it is not prepared to deal with electrical emergencies affecting our national security. Federal plans and programs for managing electrical emergencies which may arise from war, sabotage, or terrorism are inadequate or nonexistent. Further, Federal guidance and coordination with respect to such electrical emergency preparedness is lacking.

#### FEDERAL RESPONSIBILITY FOR ELECTRICAL EMERGENCIES

Federal responsibility for electrical emergency preparedness involves both DOE and FEMA. DOE has specific responsibility for preparing national emergency plans and developing programs covering electrical power emergencies resulting from war, sabotage, or terrorism. FEMA has responsibility for coordinating overall Federal emergency preparedness including policy, planning, and programs.

DOE, under Executive Order 11490, October 28, 1969, as amended, is required to prepare national emergency plans and to develop preparedness programs covering electrical power generation, transmission, distribution, and utilization. This Executive Order is, in part, based on the National Security Act of 1947, the Defense Production Act of 1950, and the Federal Civil Defense Act of 1950, as amended. It generally concerns Federal preparedness in national emergency type situations that may involve U.S. national security. In our view, the Executive Order covers sabotage and terrorism. Within DOE, the Economic Regulatory Administration is responsible for electric emergency planning. 1/

FEMA, created by reorganization plan number 3 of 1978 and assigned functions by Executive Order 12148, July 20, 1979, replaced several agencies. 2/ It is responsible for establishing Federal policies for, and coordinating all civil defense and civil emergency planning, mitigation, and assistance functions of executive agencies. In addition, under Executive Order 12148, FEMA is required to periodically review and evaluate civil defense and emergency functions of the executive agencies, report annually to

---

1/On February 24, 1981, DOE announced its intention to reorganize and transfer energy emergency functions from the Economic Regulatory Administration to the Assistant Secretary for Environmental Protection, Safety, and Emergency Preparedness.

2/The Federal Preparedness Agency, the Defense Civil Preparedness Agency, and the Federal Disaster Assistance Administration.

the President on these functions, and recommend improvements in planning, management, assistance, and relief at all levels of Government.

National electrical emergencies might not always lead to Federal involvement. From a national electrical perspective, what constitutes an emergency has not been defined. It is important to understand that such emergencies could occur as a result of a variety of circumstances and vary in duration. Sabotage, limited war, nuclear war and/or international crises, as well as a major natural disaster, can create severe electrical emergencies which can last from a few hours to years. However, the major vehicle for involvement at the Federal level for any emergency usually occurs only if the President declares a national emergency.<sup>1/</sup> It is most likely that such a declaration would only be initiated if conditions were severe and expected to continue for some time. Under such circumstances DOE would take front line duty in dealing with the emergency. As pointed out in the remaining sections of this chapter, DOE, however, is not prepared for handling emergencies. Consequently, if an emergency should arise Federal actions may be delayed or be less than effective.

#### ELECTRICAL EMERGENCY PREPARED- NESS PROGRAM IS INADEQUATE

DOE's current program cannot fulfill its electrical emergency preparedness function as required by Executive order. Before the creation of DOE, responsibility for dealing with electric power emergencies rested with the Department of the Interior's Defense Electric Power Administration and the Federal Power Commission. In 1977 these responsibilities were transferred to DOE's Economic Regulatory Administration to improve and consolidate electrical emergency planning. While DOE has focused on electric power supply and reliability and conducted power grid and reliability studies, it has not adequately addressed the emergency electric preparedness issue.

The Emergency Electric Power Administration (EEPA)<sup>2/</sup> illustrates this point. EEPA consists of a small DOE headquarters group and a widely decentralized field organization composed of utility company personnel. In a declared national emergency, EEPA is the Federal resource manager for electric power and is responsible for electric power preparedness planning, allocation, setting priorities for distribution, and restoration. In a December 1979 memo, the EEPA administrator noted that the resources to carry out this effort were insufficient and stated the program was barely alive.

---

<sup>1/</sup>National Emergencies Act, P.L. 94-412, 90 Stat. 1255, 50 U.S.C.A. 1601.

<sup>2/</sup>EEPA is located within ERA's Office of Utility Systems, Division of Power Supply and Reliability.



At that time and even today, EEPA only has two headquarters staff members assigned to this effort on less than a full-time basis.

The backbone of EEPA is made up of utility industry representatives who are actually carried on the rolls as special Government employees (without compensation). In the event of an emergency, these employees, under the direction and guidance of EEPA headquarters, would manage our electric power system. During our review we interviewed a number of EEPA representatives and found them for the most part

- unsure of their status, roles, and responsibilities;
- uncertain of EEPA's authority and responsibilities;  
and
- doubtful that the organization could operate during  
an emergency.

In addition, some people listed in EEPA's roster as active representatives did not know they were EEPA representatives or were no longer employed with the utility company. We also found that other than the regular telephone system, no alternate emergency means of communication (i.e., radio) exists between EEPA headquarters and utility field representatives. We were also advised that planning, training, and test exercises have not been conducted and even EEPA's 1980 annual meeting was not held. Further, many of the EEPA field representatives indicated to us that DOE needs to provide clear direction and guidance.

The lack of a serious commitment to electric emergency preparedness is not new. In August 1977 the Joint Committee on Defense Production held hearings on emergency preparedness in the electric power industry <sup>1/</sup> and found that Federal programs to prevent or cope with electrical power emergencies were fragmented, uncoordinated, and sometimes conflicting. Federal officials felt that consolidation of various organizations and functions into DOE would bring order and would result in a comprehensive policy. However, about a year later, DOE's Inspector General found that the

---

<sup>1/</sup>The Joint Committee on Defense Production was not funded in the Legislative Appropriations Bill of 1977 and, thus, discontinued operations as a Joint Committee on September 30, 1977. The jurisdiction and oversight functions were transferred to the Senate Committee on Banking, Housing and Urban Affairs. Because of the importance of electricity to defense production and the implications of the 1977 New York blackout, the Committee held hearings in this area on August 10 and 11, 1977.

DOE response to the need for national electrical emergency planning and preparedness was deficient and deteriorating.

In response to a congressional inquiry regarding this matter, DOE, in a September 1978 letter, indicated it was taking steps to improve its overall emergency preparedness. With one possible exception we did not, however, note any new DOE commitment with respect to electric emergency preparedness. On October 27, 1980, DOE notified the National Electric Reliability Council <sup>1/</sup> that an EEPA administrator had been designated and that the program would be revitalized and continued. Prior to the letter, the EEPA administrator's position was vacant for about 7 months and this is the third administrator in 3 years. If DOE does not follow up on the letter's revitalization pledge, and our discussions with DOE officials indicate no significant changes have occurred, we doubt whether any serious improvements will materialize.

#### NO COMPREHENSIVE ELECTRICAL EMERGENCY PLANS

In the event of an electrical emergency, DOE does not have adequate and comprehensive plans for mitigating and managing electric power disruptions. More specifically, DOE has not established plans to

- allocate and curtail power on the basis of national needs, and
- provide for the restoration of our electric system.

From the planning perspective, the only existing documents are DOE's electric emergency handbook which relates to nuclear war, and a draft electric emergency response plan to oil shortages which DOE has not made available to us.

The handbook was inherited from the Department of the Interior and only recently updated. This document, however, is only a "draft and is very general. For example, it states that in the emergency period EEPA should:

". . . allocate power, order wheeling and interconnection as required . . . Establish priorities for curtailment, allocation, and restoration of electric power."

---

<sup>1/</sup>The National Electric Reliability Council (NERC) was formed in 1968 with the stated purposes: ". . . further to augment the reliability and adequacy of bulk power supply in the electric utility systems of North America." It consists of nine Regional Reliability Councils and encompasses essentially all of the power systems of the United States and Canadian systems in Ontario, British Columbia, Manitoba, New Brunswick, and Alberta.

While the document includes some general guidance on national priorities and electric power curtailment, it does not set specific and firm detailed requirements. For example, it does not require that business "show window" lighting be eliminated. Rather, it just suggests a very general curtailment approach.

With respect to developing specific studies or plans for managing major electric power disruptions, restoring power, and mitigating damage, DOE was unable to provide any documentation. One DOE official stated that detailed planning is not needed and that experience in emergency situations is more important than written plans because in an emergency there is not enough time to refer to written plans on what to do. In contrast to this view, we were advised by EEPA utility representatives that planning and guidance from the Federal level is needed and, consequently, they would have to manage such emergencies on an ad hoc basis.

#### EMERGENCY PLANS ARE NEEDED

Planning is the first and most essential step in preparing for electrical emergencies. Without Federal plans to mitigate the effects of a national or regional electric emergency, the Government will be ill-equipped to deal with the situation. The burden of responding to the Nation's needs and requirements would fall solely on the utility industry. While the utility industry has had a good record in planning for and managing power disruptions from expected contingencies such as lightning, fire, or wind, it is not prepared to deal with long-term emergencies having a national impact.

The Federal Government should be developing national/regional electric power contingency plans which could be activated if such an emergency developed. These plans should address, at a minimum, how power disruptions are to be managed, and how the electric power system will be restored. In the following sections of this chapter we discuss some essential elements which could be included in each of these plans.

#### Plans to manage disruptions

To be prepared to manage and distribute available electric power in the Nation's best interest, the Government must establish sound and workable plans. Adequate planning must anticipate the conditions which will exist and ask and answer basic and numerous questions about what the major problems will be and how they will be handled. For example, DOE should determine what the priority electric uses will be, who the priority customers will be, what electric uses should be prohibited and under what circumstances. Questions along these lines cannot be efficiently and effectively answered during the emergency period because they are highly complex, involve competing demands for power, and affect diverse segments of the Nation.



In our view, addressing such issues before hand is a much more realistic approach because it

- permits the consideration of diverse input,
- allows sufficient time for establishing criteria for determining priorities, and
- provides a blue print on which everyone can rely in the event of an emergency.

While we recognize that planning cannot anticipate every possible condition it will be much easier and more efficient to modify existing plans for the actual conditions than to make on-the-spot plans for a specific emergency.

Plans for allocating available electric power and making curtailment decisions should be developed by DOE from a regional perspective with the Nation's overall priorities in the forefront. Such plans cannot be developed by DOE in a vacuum. To be effective and comprehensive, the plans must consider the diverse needs of our society, available resources--especially fuel, and include input from Federal, State, and local governments, and key industries including extensive participation by the utility industry in particular. Because these detailed plans and the means to implement them have not been established by DOE, ultimately the utilities will be forced to make emergency allocation and curtailment decisions without the benefit of knowing national priorities.

#### Plans to restore the power system

DOE needs to develop plans concerning the restoration of the electric power system. Utility industry and Government officials believe the most practical means of preventing serious supply disruptions is being capable of quickly repairing damage regardless of cause. Industry officials believe they have well demonstrated their ability to quickly repair damage due to normal operations and to continually produce electrical power. Also they indicated that in the event their facilities were seriously damaged, personnel and equipment would be available from other utility companies. The officials, however, stated that if several important facilities were damaged to the point they could not function, it would not be possible to restore power to normal levels from several months to over a year.

DOE should be developing plans for assessing what resources (spare components, personnel, etc.) will be available, what resources will be needed, how the resources will be obtained and whether provisions for stockpiling key resources (spare components) to restore and maintain power systems are needed. In the event of

a severe emergency the utility industry will look to DOE for assistance in obtaining vital and scarce resources to repair and maintain the electric power system. No firm Federal plans exist for assistance in restoring the Nation's power systems.

The question of whether transformers should be stockpiled is a case in point. Present on-hand spare component policy is based on historical use, cost, and reliability criteria. They are not stocked to assure an added increment of reliability deemed to be prudent in the interest of national security, public health, safety, and welfare. The possibility of component damage caused by sabotage or war is not part of the reliability criteria. Stockpiling or standardization of components or cannibalizing parts from other systems are alternatives. These questions need to be studied and resolved prior to an emergency.

In addition to insufficient spare components, restoration capability is also hindered by the lack of a central Federal effort to manage the restoration process. Even if EEPA was a viable operating agency, it has not developed the restoration plans needed to supervise such activities as assessing damage, locating materials and manpower, and determining priority restoration needs. This appears to be left to the utilities. As a result of these two weaknesses (lack of plans and components), the Nation does not have an adequate emergency restoration capability.

Restoration plans should establish priorities of action considering national security, health, and safety needs. Procedures for coordination and communication with the utility industry, non-utility industries, and government agencies must be provided if the Nation is to recover. Specific restoration plans should recognize critical loads and give special attention to installations and activities necessary for national defense and survival. Procedures could be established to provide for damage assessment and dissemination of information to restore our electric power systems.

#### LACK OF FEDERAL COORDINATION AND GUIDANCE

Overall, we found problems in Federal coordination with respect to electric emergency preparedness. Because electricity is essential to almost every aspect of our modern society, Federal agencies other than DOE have an important interest in the availability of electricity. Even though they do not have responsibility for electric planning, such plans will have impact on their missions. FEMA, with overall responsibility for emergency policy, direction, planning and coordination, must assure that DOE develops emergency electric plans which are compatible with other agency missions and that other agencies work with DOE in this effort. This has not happened.

We were advised by both DOE and FEMA officials, that FEMA has not conducted any audits or reviews of DOE's emergency electrical preparedness activities nor has it required any detailed electric preparedness reports. Further, we found that both the Department of Commerce and FEMA had contracted for studies dealing with the vulnerability of our electric power system to terrorism and sabotage. The studies, we were advised, were undertaken because electricity is vital to the Nation's economy, and the agencies felt they had an interest in the area. DOE, however, was not actively involved in the projects. Although the individual contractors did consult DOE experts in the electric area, DOE should be taking the lead in these studies.

We also found that a conflict which existed between the Department of Defense (DOD) and DOE had not been satisfactorily resolved. The conflict centered on identifying utility facilities vital to the national defense. DOD, within its Defense Industrial Facilities Protection Program, maintained and conducted security surveys of key utility facilities. At the insistence and persistence of DOE, DOD finally agreed in the spring of 1980, after some discussion, to discontinue the utility list and to stop related security surveys. DOE objected and maintained, that considering the complexity of the power system and that selection of key individual electric facilities was arbitrary, the listing did not give a complete picture of what is necessary for supplying end users with reliable power.

## CHAPTER 4

### CONCLUSIONS AND RECOMMENDATIONS

The Federal Government, because of the severe consequences of electric power disruptions, must be concerned with the management and recovery of the Nation's electric power system during major emergencies resulting from war, sabotage, or terrorism. The Nation's power system plays a vital role in our economic and social well being and is essential to our national defense. The power system, however, is highly vulnerable to damage caused by war, sabotage, or terrorism. Damage to the electrical system from such acts could result in power disruptions with severe consequences. A sustained major power disruption could cause or result in unemployment, crippled production, impaired national defense, food shortages, and cause extreme hardship for the public. To deal with such emergencies, DOE is charged with developing national plans and programs covering electric power generation, transmission, distribution, and utilization. DOE, however, has not developed an adequate program or plans to deal with such emergencies and, consequently, it is not prepared to effectively cope with major power disruptions.

#### CONCLUSIONS

While the Nation has never experienced an extensive or prolonged electrical emergency, there is no assurance that such an event will not occur. We found that the Nation's electric power systems are highly vulnerable. As pointed out in chapter 2, it would be relatively easy to create, by sabotage, extended power disruptions. The 1977 New York blackout initiated by lightning and the more recent 1980 Utah blackout initiated by a fire illustrate how minor disturbances can disrupt an electrical power system. Acts designed to damage key facilities and equipment which are vital to the operation of the power system would have more severe consequences and take much longer to repair or replace. In the case we examined, such a disruption would impair the operations of key military facilities and major industries, and affect the health and safety of the region's population. Attacks in other regions or damage from war could result in even more severe repercussions.

The Federal Government is the only organizational entity capable of effectively responding to an electrical emergency having national implications. In legislation, the Congress has recognized the need for national emergency preparedness, and under executive order, the President has specifically charged DOE with electrical emergency preparedness and planning. While the utility industry plans for and effectively handles expected operational type emergencies (equipment failure, storms, and so forth), it is not prepared to handle the consequences of deliberate and widespread physical damage to the power system on its own. In such an event, resources

to repair the system would be hard to obtain, and decisions on how to allocate and distribute power would be difficult to make. This would most likely require Federal assistance and involvement.

While the participation of both utility companies and State governments would be necessary and vital in coping with the electrical emergency, the ultimate authority and responsibility for managing the emergency would have to rest with the Federal Government. Neither the utility industry nor States can determine what is in the Nation's best overall interest. In addition, utilities have obligations to provide their customers with power and could face adverse legal and financial consequences by curtailing customers on their own. Even State governments, which generally have jurisdiction over utilities, cannot be expected to handle this situation. An action by one State may adversely affect another State because the electrical power system is not tied to State jurisdictional boundaries. Consequently, the Federal Government is in the best position to make decisions which consider all interests.

In our view, DOE, has not fulfilled its electric emergency preparedness role, has not developed a meaningful program to address this specific responsibility, and has not developed adequate plans to deal with electric emergencies. DOE has not supported its Emergency Electric Power Administration and had just two employees devoting less than full time to this enormous responsibility. Consequently, it has not been able to develop and conduct planning, training, and test exercises or hold regular annual meetings. DOE, however, is creating an illusion of preparedness by allowing this program to continue for all practical purposes in "name" only. In addition, FEMA which has overall responsibility for Federal emergency preparedness and is required to develop policies for and coordinate specific emergency planning, has not adequately supported and encouraged this effort by providing effective guidance, coordination, and assistance.

The need for thorough and comprehensive planning cannot be over emphasized. Having electric emergency plans developed before an emergency so they can be quickly activated is absolutely essential to avoid delay in responding. Also, this will avoid the need to make difficult decisions with limited knowledge in the midst of confusion. While planning cannot anticipate all possible situations, if properly done, it will provide the knowledge needed to deal with most situations. Unanticipated situations can then be handled with minimum difficulty. In any event, once an electric emergency occurs, it will be too late to make adequate preparations, and the actions taken by Government will not have the benefit of prudent thought and study.

## RECOMMENDATIONS TO THE SECRETARY OF ENERGY

We therefore recommend that the Secretary of Energy carry out his responsibility for electrical emergency preparedness and provide adequate resources to the Electric Emergency Power Administration. In this regard DOE should develop a program to deal with major power disruptions which may arise from acts of war, sabotage, or terrorism. In developing a credible and effective program, we do not envision that DOE would need to dedicate extensive resources to this effort, and, in fact, should first evaluate whether existing resources within the Department could be reallocated to carry out this function. DOE's role should be that of leader in working with the utility industry, other Federal Government agencies, and State and regional entities to help develop and maintain detailed electrical emergency plans. Because electric power systems cover wide areas and impact on many and various aspects of our society, the participation and assistance of these groups should be emphasized to assure that effective and realistic plans are developed.

To do this, we recommend that the Secretary of Energy work closely with the groups identified above to help develop national/regional plans for such electrical emergencies which will

- enable power disruptions to be managed by the utility industry through established priorities for curtailing power by use and type of customer and

- assist the utility industry in restoring power in the event of severe damage to the electric power system.

As part of its emergency planning efforts, DOE should (1) examine how electric power will be maintained and managed; (2) establish priorities for uses, curtailment, and restoration; and (3) maintain continuity and coordination with other Government agencies and industry. Because priorities and needs are not necessarily the same from region to region, planning should be done on a regional level and directed toward the national interest. Further, DOE should

I

- identify electric facilities which are important to the national defense,

- consider the need to stockpile or to make other provisions for replacing key equipment and supplies in the event of a major electrical emergency, and

- require that the Emergency Electric Power Administration conduct regular meetings, revise and test plans, and conduct training seminars for essential emergency personnel.



RECOMMENDATIONS TO THE DIRECTOR OF THE  
FEDERAL EMERGENCY MANAGEMENT AGENCY

To foster improvement in this area, we recommend that the Director of the Federal Emergency Management Agency

- actively monitor DOE's efforts to vitalize its emergency electric power program and develop associated plans,
- require progress reports from DOE and review DOE's progress, and
- actively assist, support, and coordinate DOE's efforts especially with respect to other Federal agencies.

RECOMMENDATIONS TO THE CONGRESS

The Congress, following the 1977 New York blackout, conducted an investigation and found Federal electric emergency preparedness to be inadequate. After some 3 years, nothing has significantly changed. In commenting on a draft of this report, FEMA and NERC staff recognized both the need to improve and the importance of national electric emergency planning. DOE's comments on the draft did not indicate that it would take any positive steps to make any improvements. If DOE's comments on this report indicate that it will not develop national/regional plans for electrical emergencies, then GAO recommends that the Congress enact legislation requiring that appropriate plans be developed by a specified date.

AGENCY COMMENTS AND OUR EVALUATION

A draft copy of this report was provided to the National Electric Reliability Council (NERC), Federal Emergency Management Agency (FEMA), and Department of Energy (DOE) for comment. Their comments are contained in appendixes I, II, and III respectively. The following sections summarize the comments and our evaluation.

National Electric Reliability Council

NERC staff said they support our view that preparedness for emergency disruptions is most desirable and that the present Federal mechanisms for dealing with national emergencies is inadequate. Further, comments were made by NERC to elaborate on its views and pointed out that its comments are consistent with the discussion and recommendations in the report. Specifically, NERC commented that the Federal role should focus on establishing "before the fact" policies and guidelines such as prioritization of the electric loads served by the utility industry and leaving the details

of management and operation to the utility industry. We agree with the NERC's comments.

Federal Emergency Management Agency

FEMA agreed with our recommendation to them to foster improved planning for responding to major power disruptions and agreed that DOE should provide the resources necessary to develop comprehensive plans. Further, FEMA indicated it will provide appropriate guidance to DOE and work closely with them to expand electric emergency planning to cover a wide range of emergencies including major disruptions. FEMA stated, however, that the report distorts the status of current planning efforts by presenting generalizations and ignoring significant elements of the power industry.

We do not believe that our report distorts the status of current planning efforts and, in fact, NERC believes the report presents a fair assessment of current planning. While we do not dispute that utilities can address most interruptions and that local jurisdictional and metropolitan plans are generally in place, such plans cannot effectively deal with an electrical emergency having national/regional implications. Even the utility industry which has extensive plans and experience in dealing with power outages caused by accident, weather, and equipment failure cannot adequately deal with electrical emergencies having long term and national/regional impact. As pointed out in our electrical emergency scenario on page 8, damage to just a few key facilities can result in widespread and long lasting power disruptions having regional and national consequences. Again, we note that NERC in commenting on our report did not question these points, but recognized that the present Federal mechanism for dealing with national emergencies is inadequate.

We do not agree that our report ignores important elements of the power system or makes generalizations. On the contrary, we believe FEMA's statement that powerplants service a community or area in a manner comparable to a local water utility, bus system, and fire department is not only a generalization itself, but one which is invalid. To illustrate, individual electric utility systems are interconnected and electricity from power plants in one geographical area is instantaneously transmitted to other geographical areas for extended periods of time and on a regular basis. Although local water utilities and fire departments can do this, they cannot do it on a regular basis for extended periods of time or instantaneously.

Department of Energy

DOE commented that the basic premise of the draft report causes it to be misleading since no differentiation is made between nondefense and defense related emergencies. DOE does not dispute that its Emergency Electric Power Administration (EPPA)

is tasked with defense responsibilities and recognizes that this area is deficient. DOE, however, implies that more is being done with respect to electric emergency preparedness by stating its Division of Power Supply and Reliability has established a comprehensive electric emergency response activity. DOE indicates that specific electric utility reporting requirements have been established and that its role is to monitor and coordinate Federal resources available to mitigate the impact of such disruptions.

We do not dispute that the Division of Power Supply and Reliability carries out such activities. These activities however, are not sufficient to address the concerns of our report. Conducting investigations of ice storm power outages, collecting data on power operations and monitoring electric power system disruptions do not provide any capability for dealing with major electrical emergencies. Only a preparedness program with a viable emergency operating organization and plans can deal with such emergencies. The Emergency Electric Power Administration which is under the Division of Power Supply and Reliability is not a viable organizational entity nor does it have adequate emergency plans. Further, such plans do not exist any where within the Division of Power Supply and Reliability. In our inquires along these lines, we were told that the Division only collects information, monitors oil back-outs, conducts studies, and does not engage in planning for emergencies. As noted in the report, one DOE official even stated that detailed planning is not needed and that experience in emergency situations is more important.

DOE, in a later section of its comments, states it has organizational plans to assist the electric utility industry in restoring power and that these plans focus on DOE as a coordinator. Despite our inquiries, DOE did not provide us with any documentation on such efforts and we note that it provides no specific information on this subject in its comments. Further, in attempts to clarify some of these issues, DOE canceled a scheduled meeting to resolve such problems.

While the Executive order establishing preparedness responsibilities does not specifically address sabotage and terrorism, we have been orally advised by FEMA that it considers the Executive order to cover situations involving sabotage and terrorism. This position is contrary to the one followed by DOE in its comments to us. As a practical concern, prudent planning for dealing with wartime emergencies would provide the structure for dealing with emergencies resulting from sabotage or terrorism. In our view, prudent planning dictates that DOE anticipate such electrical emergencies. As noted by NERC, whether enemy action or natural phenomemon renders more facilities unavailable, available electric power will likely be less than the demand for such power. If the Emergency Electric Power Administration was viable and had plans for what DOE identifies as defense related emergencies, it would be fairly well along in having the capability to deal with what it terms nondefense emergencies.

DOE comments that emergency planning is the responsibility of individual electric utilities and that other than under conditions of declared national emergencies no Federal statutory authorities are available for establishing priorities of electric service or curtailment. As noted in our report, DOE is responsible for electrical emergency planning and the Federal Government would only have a role if a national emergency was declared. We do not dispute that electric utilities are responsible for and do plan for electrical emergencies of a normal and expected nature (fire, floods, storms, and so forth). They do not, however, plan for major long-term emergencies which would have national impact. This is the issue our report addresses and even NERC recognizes the point and the need for Federal direction and involvement. As discussed earlier, DOE has not developed an adequate electric emergency preparedness program or plans.

In the context of the report we question the validity of DOE's statements that it is not aware of any significant problems with coordination in the electric power emergency preparedness area and that it maintains contact with FEMA, the National Electric Reliability Council, the electric utilities, and other organizations. While we recognize that DOE maintains contacts with other agencies and organizations, this does not prove that there are no problems in coordination of electric emergency preparedness. We note that DOE did not even conduct its 1980 EEPA annual meeting. Such annual meetings are intended to bring both industry and Government together on a regular basis for the purpose of maintaining and improving electric emergency preparedness and planning. We also point out both FEMA and NERC did not dispute these points and support our recommendations to improve planning for major power disruptions. Further, FEMA even said that it will work closely with DOE to expand emergency electric planning.

Also, DOE's comment regarding the timing of our interviews is incorrect. Assignment interviews were conducted into December 1980, and contacts were maintained until February 1981 with both DOE, FEMA, and industry officials. Our subsequent contacts did not reveal any new activities which would affect our findings or conclusions.

DOE recognizes that the EEPA program is deficient and indicates it has attempted to correct the shortcomings. DOE, however, implies it has not been able to make improvements due to ceiling and budget restrictions. As pointed out in the report, we do not believe DOE needs to dedicate extensive resources to this effort and should evaluate whether existing resources could be used. Also, as noted, we would anticipate that the development of effective and realistic plans would require the participation of the utility industry, other Federal Government agencies, and State agencies.

In our view, DOE seems to be missing a basic message of the report. The report points out that utilities have performed well in meeting power interruptions of a localized and short-term nature and the power system is very dependable. Should an electrical emergency of a long-term nature covering a large geographical area occur, utilities could still operate the power system. To reflect national security interests, however, Federal plans need to be in place to give the utility industry guidance and assistance in setting priorities for power use and restoration. This is the essence of our recommendations to DOE and we note that comments from NERC staff support this view.

With respect to DOE's concerns regarding the accuracy of the information, it states (1) we do not define what a long-term power disruption is, (2) we should realize that planning for such events is not all encompassing, (3) an increase in security or manpower in these areas would not enhance reliability or survivability of the power system, and (4) our statement that "...studies assessing and analyzing the consequences of physical damage to regional power system or the Nation have not been done" is misleading.

After considering DOE's comments, we continue to believe that the information contained in the report is both fairly presented and accurate. We note that the National Electric Reliability Council, authorities in the utility field, did not challenge our knowledge or understanding of the electric power system. Further, their comments commend us for our prudent use of the word "long-term."

In our view DOE's concerns regarding all encompassing plans and security are taken out of the report's context. We do not state that plans have to be all encompassing. Rather, the report recognizes and states on page 17 that planning cannot anticipate every possible condition. Nor do we state or suggest increased security or manpower would improve power system reliability or survivability. To the contrary on page 3 of the report we point out it may not be possible to protect the electric power system.

With respect to DOE's objection to our charge that it has not studied the possible consequences of major power disruptions, we note that a study done for FEMA has recognized the same point. To support its position DOE cites that it has conducted investigations on ice storm power outages. DOE, however, does not point out the study was performed by a contractor, completed in September 1979, and is not relevant to the subject area of our report because it focuses only on the distribution systems of local utilities and has no bearing on regional/national power disruptions.

In commenting on the report, DOE suggested that GAO meet with it to clear up some misconceptions. While the draft report was with DOE for comment, we agreed to meet with agency officials and discuss and clarify any questions or misunderstandings regarding the report. DOE, however, canceled the meeting and did not re-schedule it.



APPENDIX I

APPENDIX I



**NATIONAL  
ELECTRIC  
RELIABILITY  
COUNCIL**

---

Walter D. Brown  
President

March 10, 1981

Mr. J. Dexter Peach, Director  
Energy and Minerals Division  
United States General Accounting Office  
Washington, D.C. 20548

Dear Mr. Peach:

Thank you for the opportunity to comment on the GAO draft report to the Congress titled: "Federal Electrical Emergency Preparedness is Inadequate".

As requested in your February 10, 1981 letter, I have restricted the distribution of the subject draft report to guard against any improper disclosure.

The attached comments were submitted by members of the NERC office in Princeton, New Jersey who have expertise in the Planning and Operation of interconnected power systems. If you decide to incorporate these comments, in whole or in part, in your final report, it should be noted that they cannot be strictly interpreted as a statement by the electric utility industry since the GAO draft report was not reviewed by the NERC Board of Trustees or the NERC Regional Managers.

We hope the attached comments are helpful in developing your final report to the Congress. Please call if there is any need for further clarification or help.

Sincerely,



NERC Staff Comments On  
GAO Draft Report  
Titled:

"Federal Electrical Emergency Preparedness is Inadequate"

Summary

The NERC staff supports the view of GAO that preparedness for emergency disruptions is most desirable and that the present federal mechanisms for dealing with national emergencies is inadequate. However, the federal role should be focused on establishing "before the fact" policies and guidelines, such as the prioritization of the electric loads served by the industry with the agreement and approval of the state governments affected.

Once provided with priority guidelines, those industry personnel responsible (and accountable) for the operation of the 130 Control Areas\* of the interconnected power systems in the contiguous United States can develop, or modify, operating instructions to be consistent with the mandated priorities. Many of these "industry personnel" would automatically become federal personnel in the event of a national emergency since they presently serve as directors or major utility representatives of the Emergency Electric Power Administration (EEPA).

A secondary, but important, federal role involves the possible need for providing fuel, manpower, and equipment in the restoration process after the impact of a major disruption has been assessed by the industry and found to be beyond the resources available. The federal action required before the fact to address this concern would be the establishment of the communications path and the appropriate federal and industry contacts.

Discussion

When a generating unit or a major transmission line is rendered unavailable, whether by planned enemy action or natural phenomenon, the relationship between electric demands and available supply changes. Reserve generating capability and transmission network design have been incorporated into the overall power system plan to assure an adequate supply of electric power under reasonably anticipated contingencies.

In the event that enemy action or natural phenomenon renders more facilities unavailable than normally designed for, the available electric power will likely be less than the demand for such power; a condition occasionally encountered even today by the electric utility industry. Emergency operating procedures are an integral part of every power control center; establishing priority of the loads served, restoration guidelines, and procedures for importing emergency power to the extent possible within the generation and transmission system configuration existing at that time.

\* A Control Area is part of a power system, a power system or a combination of power systems to which a common generation control scheme is applied; i.e., it attempts to function as if it were an isolated power system with only scheduled power interchange taking place between interconnected control areas.

The NERC staff supports the view of GAO that preparedness for emergency disruptions of electric power is most desirable and that the mechanisms for dealing with national emergencies is inadequate. We emphasize national, since this is a key word that may change priorities presently incorporated in emergency procedures employed by the Control Areas of the interconnected power systems. Another key word, prudently emphasized in the GAO draft report, is "long-term". A long-term electrical disruption may also change priorities of the loads served.

NERC staff suggests that existing industry remedies to an electrical power deficiency resolve most of the concerns addressed in the GAO draft report. Federal and State efforts can be more effective if focused on the establishment of priorities for the electric loads to be served versus concern over proper industry actions. Once provided with mandated priorities, industry personnel responsible for the management of the 130 Control Areas in the United States can review and modify existing emergency operating procedures to conform to such a mandate.

Since the laws of physics govern, the response to a major long-term electrical disruption would best be managed by those most familiar with the laws, and the facilities on which they will be enforced. The industry engineers who have planned and operate the existing highly complex interconnected power system network are in the best position to manage the proper response to any major disruption. All they need are the priorities and objectives defined.

It is highly unlikely that federal agencies can establish national priorities without the participation and approval of state governments. However, this should not present any insurmountable problem once it is addressed. The New England states have demonstrated cooperative attitudes in pursuing Regional objectives as they relate to a reliable and economic bulk power supply. Such cooperative efforts by these states have permitted their combined generation and transmission facilities to be controlled from one Central Dispatch Office. Similar arrangements are in place elsewhere.

In summary, the above comments are consistent with the discussion and recommendations set forth in the GAO draft report. The major theme of the NERC staff comments is that the Industry would provide the most effective management of activities required to achieve the objectives established by the Federal government. However, as a first order of business, the Federal government must define what those objectives are. It is in this area, that the "Federal Electrical Emergency Preparedness is Inadequate".



FEDERAL EMERGENCY MANAGEMENT AGENCY  
Office of Plans and Preparedness  
Washington, D.C. 20472

Mr. Henry Eschwege  
Director  
Community and Economic Development Division  
General Accounting Office  
Washington, D.C. 20548

Dear Mr. Eschwege:

Thank you for the opportunity to comment on your draft report "Federal Electrical Emergency Preparedness is Inadequate," EMD-81-50.

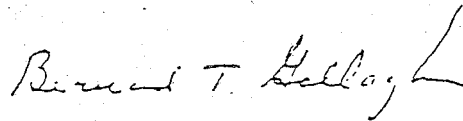
We have no problem with the proposed GAO recommendation to the Director of the Federal Emergency Management Agency to foster improvement in planning for response to major power disruptions. We agree, also, with the recommendation that the Department of Energy should provide the resources necessary to develop comprehensive plans for coping with major power disruptions resulting from natural or man-made disasters including war. The report, however, distorts the status of current planning effort in several ways. Chapters 2 and 3 contain a series of generalizations, a vague definition of an "electrical emergency" that includes a wide range of unrelated and dissimilar electrical disruptions and ignores significant elements of the power industry.

The electrical power industry is, in fact, one of the most diverse industries in the United States. The GAO report cites the industry as comprised of 3500 electric utility companies but it does not mention that those companies operate almost 11,000 power generating facilities. Many of those power plants service a community or area in a manner comparable to the local water utility, bus system and fire department. Plans are generally in place for mutual support of utilities by contiguous jurisdictions. Major metropolitan areas, whether serviced by large remote power generating plants, a number of smaller generating plants or a combination of these sources, have emergency plans for alternate sources and alternate routing of electric power to meet their needs in an emergency. A "nationwide blackout" is difficult if not impossible to comprehend under the conditions that obtain. Even a nuclear attack on the United States would not precipitate a nationwide blackout but it would substantially decrease the demand for electric power.

In a situation where a single unit of unique design or where large quantities of generating and transmission equipment are incapacitated, the long lead time for producing such equipment could easily be the determining factor in reestablishing power availability. This condition could be aggravated by the fact that a considerable amount of power generating and transmission equipment is imported because of lower foreign prices.

The electric power systems in the United States comprise a diverse and complex infrastructure. Simple generalizations about any aspect of that structure cannot provide direction for comprehensive emergency planning. FEMA will provide appropriate guidance to DOE and work closely with that Department to expand emergency planning for electric power to cover a wide range of emergencies including major disruptions.

Sincerely yours,



- Bernard T. Gallagher  
Acting Director

Enclosures



Department of Energy  
Washington, D.C. 20461

MAR 16 1981

Mr. J. Dexter Peach  
Energy and Minerals Division  
U.S. General Accounting Office  
Washington, D. C. 20548

Dear Mr. Peach:

The Department of Energy (DOE) appreciates the opportunity to review and comment on the GAO draft report entitled "Federal Electrical Emergency Preparedness is Inadequate."

The DOE has several concerns regarding the accuracy of the information contained in this draft report. These are summarized in the enclosure to this letter. The basic premise of the GAO draft report causes it to be misleading since no differentiation is made between non-defense and defense related emergencies.

More specifically the GAO draft report states:

1.--"DOE has an inadequate program for dealing with major electrical disruptions. In fact, its Emergency Electric Power Administration (EEPA), tasked with these responsibilities, is hardly alive." (See p. ii.)

This statement is misleading as it implies that EEPA is tasked with these responsibilities, when in fact EEPA is responsible for only defense-related emergencies (e.g., mobilization, limited or general war). DOE's Division of Power Supply and Reliability has established a comprehensive electric emergency response activity. Specific electric utility reporting requirements have been established such that prospective fuel supply problems, equipment outages, physical sabotage, etc., are reported to the Electric Power Monitoring Center. Response actions are developed that are deemed appropriate to particular non-defense related emergency situations.

2.--"DOE does not have adequate plans to manage and mitigate electric power disruptions." (See p. ii.)

--"Emergency plans to manage such disruptions and restore the power system, are needed." (See p. ii.)

These statements are misleading because the development of such emergency plans is primarily the responsibility of the individual electric utility and not that of DOE or any other Federal Government Agency. State Government has a more direct responsibility. The role of DOE in non-defense electric power emergencies is to monitor and coordinate the Federal resources available to mitigate the impact of such disruptions. Several ice storm related power outages have been investigated, along with cable failure and other significant electric power outages for the purpose of identifying any weaknesses in utility plans and procedures. The reports of such investigations contain specific recommendations to prevent future re-occurrence and to mitigate the impacts. Sections 202(c), and 202(d) of the Federal Power Act provide the DOE with authority to order the interconnection, generation or transmission of electric energy to alleviate emergencies. Rules have been issued to implement this statutory authority. These have been utilized several times in the past few years.

3.--"Problems exist in Federal coordination with respect to electric emergency preparedness." (See p. ii.)

Again, the non-defense/defense differentiation is not made. However, the DOE staff is not aware of any significant problems in the electric power emergency preparedness area. DOE maintains regular communication with FEMA, the National Electric Reliability Council, the electric utilities and many other appropriate organizations with responsibilities in this area. It should be noted that a companion GAO report on fuel disruptions for electric utilities was initiated along with this GAO report and that the last interviews for both reports were conducted several months ago. A considerable number of activities have been initiated since that time which affect the findings and conclusions of this report and which have not been considered by GAO.

With respect to the GAO recommendations, DOE offers the following comments:

1.--"Carry out his responsibility for electric emergency preparedness." (See p. iii.) This statement needs further clarification as to whether defense or non-defense emergencies preparedness is intended. Also GAO should be specific as to which statutory responsibilities are not being carried out.

2.--"Provide adequate resources to its Emergency Electric Power Administration." (See p. iii.) The current structure has been and continues to be limited due to ceiling and budget restrictions. EEPA has recently developed a four-year revitalization program that will be pursued to the extent



SECTION I

ENERGY AND VULNERABILITY

## ENERGY AND VULNERABILITY (1.0)

### Introduction and Overview (1.1)

The fact that the United States depends on imported petroleum to meet almost half of its demand has become widely recognized. The numerous economical, political, social, and environmental repercussions that could result from this dependence, however, are not yet fully realized. As Joseph Nye says, "Oil is the heart of the energy security problem and will remain so for at least the next decade."<sup>1</sup>

Because the energy sector is vital to the industrial, agricultural, communications, and other sectors of a society, a failure in the ability to produce and distribute energy throughout the United States would leave the country unable to support or defend itself. In short, the present energy situation makes the United States vulnerable. Our national security is at risk.

Vulnerability refers to the degree to which an energy supply and distribution system is unable to meet end-use demand as a result of an unanticipated event which disables components of the system. The kinds of events referred to are sudden shocks, rare, and of large magnitude.<sup>2</sup>

There are two major forms of vulnerability against which the United States must protect itself. The first is the insecure availability of imported energy supplies and strategic materials necessary for adequate levels of defense, economic growth, and stability.

The second form of vulnerability is the centralized nature of the American energy system. Because energy is vital for maintaining the U.S. economy, an adversary would enjoy a strong strategic advantage by crippling that energy system. Centralized energy facilities add to the degree of vulnerability of the U.S. energy systems because, as enemy targets, they are larger and there are fewer of them.

A strategy of targeting centralized energy facilities, for example was successfully used against Germany during World War II. Today, the existence of centralized energy facilities is recognized as a primary source of national vulnerability. Studies have demonstrated the likelihood of targeting refineries in the advent of modern war, and various other facilities including nuclear power plants.

One strategic solution that would decrease vulnerability is the implementation of dispersed and renewable energy sources. Increased use of dispersed energy sources and a transition to renewable sources in the industrial, agricultural, commercial and residential sectors would ultimately result in independence from foreign energy sources. In addition, the vulnerability of the centralized energy system, dependent on a limited number of massive facilities, would be substantially reduced.

The story of how cheap, easily available petroleum fed the industrialized nation's insatiable appetite for increasingly large shares of energy is by now well known. What is not as widely published nor understood is why Americans refused to recognize the peril that dependence upon a few unstable nations, inexperienced in playing a central role in international politics, brought to the entire U.S. economy. Even the "oil crisis" in 1973-74 that resulted in quadrupled prices in oil didn't reverse the trend of continually greater dependence on imports from a very small number of suppliers. The industrial economies grew at an average annual rate of 3.4 percent during 1970-78<sup>3</sup>, and the real price of oil actually fell in 1974-78.<sup>4</sup>

The events of 1973-74 were considered a unique and isolated experience. American life, considerably dependent of foreign supplies of oil, continued with only slight acknowledgement that cheap and abundant oil would never be available again. Evidence of this lack of concern was demonstrated by the initial reluctance of Congress to pass President Carter's proposed "moral equivalent of war." Instead, a weakened National Energy Policy Act passed in 1978. In order to lessen dependence of foreign supplies, the Act called for heightened production and consumption of domestic sources, consisting chiefly of coal and nuclear fuel. The production of these energy resources, however, entails a number of economical, social and environmental concerns, which have greatly hindered their accelerated usage.

Not until the Iranian Revolution of February, 1979, did the American public begin to acknowledge how serious a threat this excessive dependence on imported petroleum represented. "The oil lost in the first half of 1979 amounted to only one percent of the world total, yet inadequate preparations and panic responses produced gasoline lines and a 120 percent price increase."<sup>5</sup>

Although most OPEC countries "produced above their announced ceilings in early 1979 to help consumers cope with the Iranian shortfall, "many of the world's leading oil producers recognize the exhaustibility of their resources and have reduced production levels. "OPEC exports are expected to decline from 28.3 million barrels per day in 1979 to 22 million in 1985 and to 17.29 million by 1990."<sup>6</sup>

Our dependence on a small group of unstable, unpredictable nations results in a serious supply vulnerability. The largest oil producing country, Saudi Arabia, is no longer able to moderate the more extreme members of OPEC who wish to cut back production and raise prices to the limits that the market will support. In addition, the United States has become increasingly dependent on nations that, to one degree or another, regard the West as an enemy and show little compunction in subordinating oil supply to other considerations.

The Department of Energy estimates the domestic cost to the U.S. economy would be \$323 billion if ten million barrels per day (mbd) were curtailed for a year (slightly more than Saudi Arabia's production level) and \$686 billion if the entire Persian Gulf oil supply (so precariously reliant on the Straits of Hormuz) was suspended for one year.<sup>7</sup>

In spite of the fact that the U.S. is the second largest producer of oil, contributing 8.5 mbd to the world's supply, we are simultaneously the largest importer, requiring over 6.4 mbd.<sup>8</sup> Proved domestic crude oil reserves have declined sharply, following the discovery of Alaskan reserves in 1970. The rate of production has declined with the decrease in reserves, resulting in a decreased production rate of sixteen percent from 1970 to 1975.<sup>9</sup> As the rate of growth in energy demand continues to climb, it becomes very unlikely that the U.S. can depend solely on domestic resources to meet its oil demand.

Natural gas trends have been very similar to those of domestic oil reserves and production. Proved reserves also declined after 1970 and decreased rates of production followed, having peaked in 1973.<sup>10</sup> As with oil, the U.S. is not only one of the largest natural gas producers, but is also one of the largest importers. Imports comprise about five percent of total natural gas consumption, as compared to over 36 percent of total petroleum consumption.<sup>11</sup>

U.S. coal reserves, on the other hand, are plentiful. Over 600 million tons of coal are produced in the U.S. every year. There are a number of well-known environmental liabilities inherent in the mining, transportation and burning of coal, however.

Nuclear power has been considered a major solution to energy needs for the last few decades. However, it has become one of the most controversial issues in America today. The lack of a viable nuclear waste disposal program, the fear of nuclear accidents, and the threat of proliferation all add to the public's growing resistance to atomic power providing more than its current eleven percent contribution to electric generation.

Additionally, there is no place to store the radioactive materials without risking radiation exposure of some kind. Waste is being temporarily stored until facilities and handling methods can be developed that will alleviate the dangers of radioactive contamination.

Likewise, the possibilities for accidents in nuclear power plants either elicit absolute opposition or are unequivocally defended by technologists who contend that the chances of a life-threatening accident are miniscule. As long as events such as the near-meltdown at Three Mile Island provide support for the opposition's viewpoint, the debate will continue.

The issue of nuclear proliferation also provokes debate. Because the topic is so controversial and complex, it warrants some elaboration. The production and use of nuclear fuels for civilian power generation can lead to the use of bomb-grade radioactive materials which enhances the spread of nuclear weapon capabilities to several nations. This increases the potential for nuclear terrorism and nuclear warfare.

Currently, the United States employs light water reactors (LWR's) to generate electricity. "Ordinary LWR's use a low enriched fuel (about three percent

Uranium-234 and 97 percent Uranium-238) which is useless for bombs. . . without further enrichment."<sup>12</sup> National policy prohibits the export of enrichment technology from the United States due to proliferation concerns.

A conventional assumption has been that spent fuels would be reprocessed to produce fresh fissionable fuels for reuse. Eventually LWR's would be replaced with "breeder" reactors that breed additional fuel (Plutonium-239) in the fission process, thus alleviating dependence on dwindling supplies of Uranium-235. However, the breeder reactor nuclear fuel cycle can produce weapons-grade plutonium more readily than conventional nuclear fuel cycles. Both breeder reactor development and fuel reprocessing from LWR's have been delayed by the U.S. government because plutonium might be exposed to potential misuse through proliferation. The debate now centers around whether we should maintain our policy of breeder reactor technology prohibition and continued dependence on diminishing uranium supplies or develop breeder reactors. Active development of breeder reactors is underway by several European nations, but even with full development, several decades will be required to reach maturity in such programs. The Harvard Business School's Energy Project summarized the breeder issue as follows in their report, Energy Future:

Contrary to a widespread impression, even the world's most technically advanced breeder reactor development program (in France) is decades from making any significant addition to that country's nuclear power supply. . . Events beyond the early 1990's are, of course, anyone's guess, but the history of the light-water-reactor development effort cautions against expecting too much too soon from a new and highly complex technology. Certainly for the indefinite future there would seem to be little or no realistic possibility that breeder reactors could have any practical effect on the waste disposal problem.<sup>13</sup>

This study considers the use of dispersed, decentralized, and renewable energy resources as a long-range strategic energy option. Numerous reports exist today that discuss the likely contribution renewables can offer in the near and distant future. There is considerable divergence among the resulting projections and forecasts, however, due in part to the variable and conflicting assumptions employed.

The realization that greater energy efficiency, conservation and development of renewable energy resources can help to decrease our dependence on foreign oil has become more widespread. Public acceptance is growing due to favorable demonstrations of successful renewable systems. The technologies that were once too expensive and exotic to consider are now cost-effective in a number of cases.

## Strategic Materials and Vulnerability (1.2)

The resources required to produce many components of a number of conventional and alternative technologies are referred to as "strategic materials." These minerals and metals are necessary to a number of key U.S. industries, including aerospace, electrical equipment, nuclear power, and communications.

The issue U.S. policymakers face today regarding strategic materials is our reliance on imports. The United States currently imports between 90 and 100 percent of most of these elements. "It is scarcely an exaggeration to suggest that the West is every bit as vulnerable to chaos from a cutoff of strategic minerals as it is to an oil cutoff."<sup>14</sup> Table 1.2-1 illustrates U.S. dependence on some of these strategic materials.

Many of these materials exist in presently or potentially unstable regions of the world, such as South Africa, Cuba, Brazil, Zaire, Morocco, Jamaica, and Zambia. In addition, the Russians have been establishing contacts and power bases in or around many of these regions, causing concern about the future availability of supplies. The problem is not only the uncertainty generated by dependence upon unstable regions, but also the threat to national security that this situation poses since many of these materials are crucial for advanced military hardware in addition to power generation. Table 1.2-1 shows some of the extent of this reliance.

A number of critical and strategic materials are used in the construction and maintenance of a wide range of energy facilities, power plants, and heat engines of various kinds. As a general rule, higher technology equipment and equipment which must operate at high heat ranges, require the use of specialized, exotic and strategic materials to a greater degree than simpler, somewhat lower technologies. The Nuclear Regulatory Commission (NRC) has studied the requirements of nuclear power plants, which use materials such as aluminum, antimony, asbestos, beryllium, cadmium, chromium, cobalt, copper, lead, manganese, mercury, nickel, platinum, silver, tin, tungsten, and zinc. Table 1.2-2 lists the materials needed for reactor cores based on U.S. experience in the construction of large nuclear power plants.

Unlike other energy technologies, many of the critical materials utilized for reactor cores cannot be recycled in the future due to excessive radioactive contamination. This unique feature of nuclear power adds significance to policies which commit large quantities of scarce, strategic materials to this sector of the energy economy. Other energy technologies, such as new synfuels processes, are also heavy users of critical materials. Vast increases in synthetic fuels production or the construction of large, modern power facilities will require substantial amounts of these threatened and dwindling materials.

Legislation has been enacted during the past 30 years which attempts to protect the United States' military interests from disruptions in the flow of strategic materials. The Defense Production Act of 1950 "can be used to stimulate domestic production of metals and materials that are critical to national security."<sup>15</sup> Title I sets priorities and allocations under the Defense Materials and Defense Priorities



Table 1.2-1<sup>16</sup>

U.S. RELIANCE ON STRATEGIC MATERIALS

<u>Material</u>	<u>Percentage of U.S. Consumption from Imported Materials</u>
Titanium (rutile)	100 <sup>f</sup>
Columbium	100 <sup>d</sup>
Tin	100
Beryllium	100 (approx.) <sup>b, c</sup>
Germanium	100 (approx.)
Platinum	100 (approx.)
Manganese	98 <sup>c</sup>
Tantalum	96 <sup>c, d</sup>
Aluminum	93 <sup>a</sup>
Chromium	90 <sup>a, c</sup>
Cobalt	90 <sup>c</sup>
Nickel	77 <sup>e</sup>
Tungsten	59
Copper	n.a.
Molybdenum	n.a.

- a Reliance on politically unstable regions.
- b U.S. has large potential supply.
- c Reliance on politically unstable African region (e.g. South Africa)
- d Reliance on politically unstable Asian region (e.g. Thailand)
- e U.S. has large potential resources, but domestic production has been limited due to technological and environmental problems.
- f Reserves have been identified in the U.S., but none mined.

Systems regulations; Title 3 enables the government to underwrite the expansion of domestic production of strategic materials and raw materials for which the U.S. has a high degree of import dependence; and Title 7 lists administrative regulations which implement the rest of the Act.

Table 1.2-2<sup>17</sup>

ESTIMATED QUANTITIES OF MATERIALS USED IN REACTOR CORE  
REPLACEABLE COMPONENTS OF WATER-COOLED NUCLEAR POWER PLANTS

Material	Quantity Used in Plant, <sup>a</sup> kg	World Production, <sup>b</sup> metric tons	U.S. Consumption metric tons	U.S. Reserves, <sup>b</sup> metric tons	Strategic & Critical Material <sup>c</sup>
Antimony	1.7	65,400	37,800	100,000 <sup>d</sup>	Yes
Beryllium	2.8	288	308	72,700	Yes
Boron	3,363	217,000 <sup>e</sup>	79,000 <sup>e</sup>	33 x 10 <sup>6</sup>	No
Cadmium	206	17,000	6,800	86,000	Yes
Chromium	109,000	1,590,000	398,000	2 x 10 <sup>6d</sup>	Yes
Cobalt	61	20,200	6,980	25,000 <sup>d</sup>	Yes
Gadolinium	2,650	8 <sup>f</sup>		14,920 <sup>g</sup>	No
Iron	443,000	574 x 10 <sup>6 h</sup>	128 x 10 <sup>6 i</sup>	2 x 10 <sup>9 d</sup>	No
Nickel	55,000 314,000	480,000 <sup>i</sup>	129,000 <sup>i</sup>	181,000 <sup>d</sup>	Yes
Tin	24,000	248,000	89,000	57,000 <sup>d</sup>	Yes
Tungsten	9.3	35,000	7,300	79,000	Yes
Zirconium	1,106,000	224,000 <sup>e</sup>	71,000	51 x 10 <sup>6</sup>	No

a Quantities used are modified from the final ER for Hope Creek Generating Station, Table 10.1, Docket Nos. 50-354 and 50-355.

b Production, consumption, and reserves were compiled, except as noted, from the U.S. Bureau of Mines publications "Mineral Facts and Problems" (1970 ed. Bur. Mines Bull. 650) and the "1969 Minerals Yearbook."

c Designated by G.A. Lincoln, "List of Strategic and Critical Materials," Office of Emergency Preparedness; Fed. Regist. 37(29):4123 (Feb. 26, 1972).

d World reserves are much larger and U.S. reserves.

e Information for 1968.

f Production of gadolinium is estimated for 1971 from data for total separated rare earths given by J.G. Cannon, Eng. Mining H. 173(3):187-200 (March 1972). Production and reserves of gadolinium are assumed to be proportional to the ratio of gadolinium to total rare earth content of minerals given in "Comprehensive Inorganic Chemistry," Vol. 4, ed. M.C. Sneed and R.C. Brasted, D. Van Nostrand Co., Princeton, N.J., 1955, p. 153.

g Reserves include only those at Mountain Pass, Calif., according to the "1969 Minerals Yearbook."

h Excludes quantities obtained from scrap.

i Production of raw steel.

j Metallic zirconium accounted for 8% of total U.S. consumption in 1968.

The Strategic and Critical Materials Stockpiling Act resulted in a national stockpile of vital minerals. Presently, the total value of the stockpile inventory is about \$13 billion, but there are shortages and imbalances in several key categories that would require an estimated \$6 billion to bring the inventory to stated goals. The 1981 fiscal budget allocates \$170 million for additions to the stockpile, and it is likely that a larger request will be submitted next year.<sup>18</sup>

The National Strategic Information Center (NSIC) recently released a White Paper urging increased efforts to "beef up American stockpiles" by adhering to "resource war" tactics. The report suggests that the U.S. should design new alliances and be prepared to intervene militarily, to be guaranteed access to Mideast oil and southern African minerals. The report discusses U.S. dependence on foreign supplies. Even though there are presently sufficient supplies to meet industry's demands, the report states that the "U.S., and its allies, are increasingly unable to exert sufficient influence on the world scene to guarantee a continued flow of raw materials from the Third World--and immediate action needs to be taken."<sup>19</sup>

In addition, set-aside quotas have been established which mandate a monthly percentage of the materials production to defense-rated orders; the remaining materials are free for market consumption.

One way to alleviate imported materials-dependent vulnerability is to stimulate U.S. Domestic production. The issue of increasing American mining of these crucial minerals is being addressed in the Congress. Senator James A. McClure (R-Idaho), Representative James Santini (D-Nevada) and Senator Harrison Schmitt (R-New Mexico) have warned of threats to national security due to reliance on foreign mineral resources.<sup>20</sup>

The United States has vast resources of its own, but thus far it has been "uneconomical" to substitute the more expensive domestic resources for cheaper foreign resources. The proponents of increased domestic production hope to pass legislation revamping tax codes, anti-trust laws and environmental regulations, in addition to opening federal lands to mineral exploration.

Representative Santini, Chairman of a House mining subcommittee, in a recent hearing on the "International Resource War: Minerals Held Hostage," recommended a policy to steer the U.S. away from our growing dependence on imported minerals. At the Santini hearings, former NATO Commaner-in-Chief Alexander Haig said: "Should future trends, especially in southern Africa result in alignment with Moscow of this critical resource area, then the U.S.S.R. would control as much as 90 percent of several key minerals for which no substitutes have been developed and the loss of which could bring the severest consequences to the existing economic and security framework of the free world."<sup>21</sup> The Russians may be simply acting in their own self-interest to insure supplies and "will be forced by economic realities to continue trading their minerals on the open world market."<sup>22</sup>

The possibility of curtailment of imported strategic materials renders the United States as vulnerable as our dependence on OPEC oil. The energy

production and distribution industry is dependent on strategic materials which further deepens our vulnerability. In the past, economic considerations based on the price of a desired material were the main criteria used to determine amounts of domestic production vs. importation. Now, policymakers are learning to weigh national security against price. In some cases, it is becoming expedient to pay a higher price in dollars to stimulate domestic production of a vital resource than to import cheaper materials and pay the price of energy and materials supply vulnerability.

### Centralization of Energy Systems and Vulnerability (1.3)

Vulnerability is apparent in the evolution of the U.S. energy network. With the rapid industrialization of the United States during the late 1800s, it became evident that the introduction of larger facilities led to profitable economies of scale. Marginal costs decreased as greater numbers of goods were produced. Centralization likewise applied to the American energy production and distribution system, and today the concentration of facilities has become an integral characteristic of the economy's energy sector. (See Section 2.7, "Energy Systems and Economies of Scale" for further discussion.)

The trend toward centralization is illustrated by the electric power industry. Initially, electricity was produced in small, localized plants. The numerous small-scale electricity-producing stations gradually consolidated as improved technologies allowed increased production and more efficient distribution facilities. Demand for electric power doubled every ten years on the average, while the price of electricity in cents per kilowatt hour dropped, in real terms.

American society depends on large-scale power plants for the operation of food production and distribution, transportation, communication, and for the ability to defend itself. In short, it depends on energy for survival. Because the life blood of a modern, highly industrialized economy is its energy sources, the larger and more concentrated these sources are, the more vulnerable the economic system and armaments production are to total disruption if the energy sources are attacked or interrupted by other means.

#### Petroleum and Vulnerability (1.3-1)

The petroleum industry, for example, is very vulnerable. From the time petroleum is pumped from wells until it is distributed as refined products, it follows an increasingly centralized production chain. The centralization of petroleum operations and the development of sophisticated equipment for operating and communications make it highly vulnerable to an attacker's disruption.

Domestic production of crude petroleum is probably the least vulnerable step in the oil chain. Oil fields are dispersed over wide areas of the country, increasing the likelihood that at least some production will be maintained if a portion of the nation's oil fields is damaged or destroyed by disaster, sabotage or nuclear attack. However, approximately 50 percent of U.S. crude oil production is dependent on electric power in one way or another, adding to its vulnerability.<sup>23</sup>

Transportation of crude oil is done primarily by pipeline, a system which has some measure of protection in a natural disaster or nuclear attack since most pipelines are buried. However, pumping stations needed to move oil through the pipelines are located aboveground at approximately 50 to 100 mile (80.45 to 160.9 kilometers) intervals along the more than 66,000 miles (96,540 kilometers) of crude pipeline.<sup>24</sup>

The importance of transportation to the petroleum industry was emphasized in a U.S. Department of Interior report which estimated that each barrel

of crude oil produced in the U.S. is transported 600 to 800 miles (965.4 to 1,287.2 kilometers) before its final use.<sup>25</sup> Only about one-fourth of American crude oil does not move by pipeline. The ships, trucks and railroads used to transport this oil are also vulnerable to either direct or secondary damage; for instance, trucks surviving an attack may not be able to move over damaged roads.

The next step, refining of crude oil is considered the most vulnerable point in the petroleum system and probably the most vulnerable component of the energy industry. Nearly all crude oil is converted to gasoline and other products before use, and loss of refineries to perform this conversion would devastate the American economy. Large refineries are considered to be a prime target in a nuclear attack because of their crucial role in the economy and because they are the most concentrated segment of the petroleum chain.

Over 38 percent of domestic crude production was refined in the Gulf region of the U.S. in 1974. These refineries are concentrated in a relatively small Gulf Coast area of Texas and Louisiana, which in 1979 had 61 of the country's 311 petroleum refineries. Another 42 refineries are in California and other concentrated areas are Detroit, Chicago, Philadelphia and New York. The California, Great Lakes, Middle Atlantic and Gulf region refineries together account for about 71 percent of the U.S. refining capacity.<sup>26</sup>

The petroleum industry's reliance on electric power for many of its operations complicates the vulnerability picture since electric utilities also are vulnerable to nuclear attack. "Auxiliary power is available in some (refining) plants but the lack of power will shut down most operations," states one study of the petroleum system's vulnerability.<sup>27</sup>

Some of the federal research on energy vulnerability has suggested industry changes that would reduce damage done in a nuclear attack. However, these solutions, such as building petroleum refineries underground, maintaining separate electric power sources for each refinery and building refineries with fallout protections, are generally acknowledged to be uneconomical in an industry in which market considerations, transportation and crude oil supply are major factors determining site location for plants.<sup>28</sup>

#### Natural Gas and Vulnerability (1.3-2)

The natural gas industry is similar in many respects to the petroleum industry. Gas collected in the field must be moved to a processing plant before being transported for use in homes and industry. Production of natural gas is concentrated in only a few states. In 1978, Texas, Louisiana, Oklahoma, New Mexico, Kansas, Wyoming and Alaska produced 92.8 percent (19.97 trillion cubic feet) of the marketed natural gas originating in the U.S. The same year, Texas and Louisiana alone exported 8.24 trillion cubic feet, which was 18.1 percent of the domestic gas sold in the interstate market.<sup>29</sup>

Natural gas production, like crude oil production, is less vulnerable than other aspects of the industry because it is dispersed over a large area. Pipelines (77,766 miles (125,125.49 kilometers) were operating 1979) gather the field gas which must go to gas processing plants before distribution. The gas processing step



is roughly comparable to refining in the petroleum industry, but is less complicated. In 1974, there were 763 such plants in the country.<sup>30</sup>

Over 260,000 miles (418,340 kilometers) of transmission lines carry the gas from the processing plant to storage tanks. Transmission pipelines are considered vulnerable to sabotage and to ground shock waves from a nuclear attack. The greatest vulnerability in transmission is the fact that pipelines and compressor stations are run by automated systems. Complex communications equipment is vital to this operation, and few people are skilled in repairing it. Thus, even lightly damaged equipment could be rendered unusable if no one with the expertise survived to make repairs.

### Coal, Electric Power and Vulnerability (1.3-3)

Most energy vulnerability analyses have concentrated on petroleum, natural gas and electric power. Coal is a less complicated industry, but it remains vulnerable because of its great dependence on two other resources: electric power and transportation.

The coal industry is dependent on electric power for both strip mining and deep mining. Transportation of coal is done by railroad (about half the coal mined in the U.S. moves by rail), barge, and truck, and these modes of transportation ultimately depend on oil for the diesel fuel they need to operate. Damage to the transportation system, or the presence of fallout in areas that must be crossed to transport coal, would also reduce the availability of this fuel.<sup>31</sup>

Electric power generation depends on fossil fuels, falling water or uranium, which are converted into electric current. In 1979, 48 percent of the nation's electricity was generated by coal, fifteen percent by natural gas, thirteen percent by petroleum, twelve percent by hydropower and eleven percent by nuclear energy.<sup>32</sup>

However, those statistics vary considerably in different areas of the country. New England, for instance, relied on coal for only seven percent of its electricity, while petroleum provided 60 percent. But nationwide, electric utilities are the country's biggest coal consumers, burning about 70 percent of the coal produced in the 1970s, compared with fifteen of the nation's natural gas consumption and ten percent of its petroleum. In sum, the electric power industry is vulnerable to the availability of resource supplies as well as the threat of nuclear attack.

### Nuclear Power and Vulnerability (1.3-4)

Increasing attention is being paid to the possibility of an enemy attack upon nuclear power plants and its subsequent effects. Currently, about eleven percent of all U.S. electrical power is supplied by nuclear installations. Since nuclear power plants constitute less than 200 potential targets (including near-term proposed additions) and have the added risk in some cases of being very close to large population centers, they are prime candidates for strategic nuclear targeting or conventional bombing.

Other reasons nuclear power plants may be chosen are outlined by Bennett Ramberg:

They might be attacked because they are a guise for a nuclear weapons program. They might be threatened or destroyed because they represent one of the greatest concentrations of capital investment a country is likely to possess. A party with a stake in an ongoing conflict between two countries might consider sabotaging a facility as a means to escalate the conflict. Finally, large numbers of people in many countries have become acutely concerned about possible releases of radionuclides from power plants. Taking advantage of this fear, a belligerent could use the threat of radioactive contamination resulting from a successful attack as a means of coercion.<sup>33</sup>

Several studies also hypothesize recovery times necessary for resumption of a stable, productive economy. Again, the estimates all depend upon the assumptions made for the respective scenario. A centralized energy system that depends on relatively few power plants as compared to a dispersed network of small-scale power stations, however, would require a longer recovery period to rebuild huge power generating facilities and replace the other components of the complex energy system.

The overall dependence of the American economy on large quantities of electrical power and fossil-fueled transportation systems, combined with the vulnerability of petroleum refining facilities and significant dependence on foreign petroleum, suggests that the magnitude of the difficulty in meeting energy needs may be one of the most critical determinant(s) of the nation's long-term ability to recover economically...<sup>34</sup>

The likelihood of an assault upon domestic nuclear power plants must also be taken into account when attempting to measure the degree of U.S. vulnerability. Not only does the possibility of an external bomb attack exist, but recently the threat of damage to nuclear plants has expanded due to an increasing number of sabotage and terrorist attacks.

## Terrorism and Vulnerability (1.4)

Terrorism, according to the U.S. Department of Justice is "the calculated use of violence to obtain political goals through instilling fear, intimidation or coercion. It usually involves a criminal act, often symbolic in nature and intended to influence an audience beyond the immediate victims."<sup>35</sup>

During 1977 there were 106 acts of domestic terrorism.<sup>36</sup> Terrorism cannot be compared with usual criminal acts — it is an act directed against all of society, deliberately designed to shock, dismay and enrage.

The motive for sabotage may be equally political, but the goal is largely functional, that is, to destroy a capacity or disrupt a process typically relating to material production and often for the purpose of hampering a nation's war effort or defensive capability. The strategy may involve an intent to unsettle governmental or military authorities, or even undermine public confidence in those institutions, but the principal thrust is political. Relatively trivial incidents of sabotage are occasionally associated with labor disputes or the effort of an aggrieved party to extract revenge, or even simple extortion, but the primary concern remains in the area of defense production and capability.

There is little doubt that electrical power and fuels transported over long distances by complex routes make them vulnerable to terrorist attack and sabotage. Virtually the entire electric grid in this country consists of overhead transmission lines. Pipelines carry most of our natural gas and pipelines (some 260,000 miles (418,340 kilometers) of trunklines and gathering networks) are major carriers of petroleum products. These elements of the system (especially their function components, such as substations and switching centers in the case of electric power transmission, and aboveground valve, cutoff and pressure regulator sites for gas and oil pipelines) are essentially unguarded, vulnerable to a variety of weapons, and difficult to repair.<sup>37</sup> Nevertheless, refineries, processing plants and power facilities must be considered prime targets for internal attack.<sup>38</sup>

Similarly, the high degree of interconnections in the electric power system mitigate the consequences associated with the loss of any single power station. This last point is also true of such central facilities as refineries: "One should not underestimate the costly damage that is possible to an oil refinery, but the temporary loss of the products from one or several plants would be greatly detrimental to total energy flow, except in the local market."<sup>39</sup>

On the other hand, there are energy systems which almost seem to invite disruption by internal attack. For example, more than half of the natural gas in the United States flows from or through Louisiana, raising the spectre that a few well-executed attacks could severely cripple the nation's supply. Similarly, over 2.5 million barrels of light petroleum products flow through four major lines from the Gulf Coast to east-central and eastern states every day.<sup>40</sup>

To date, the major terrorist groups have shown no inclination to attack U.S. energy facilities elsewhere.\* As shown in Table 1.4-1, energy related attacks in the United States (all bombings) have been very minor in scale, have resulted in little damage, and have caused almost no interruption of service. By and large, they have been motivated by the rather mundane grievances of domestic groups.

It may be, however, that increased attention to the energy crisis and the heightened public perception of vulnerability in energy supply may soon attract the attention of more dangerous groups. Certainly the ongoing controversy over nuclear power will make nuclear power plants increasingly attractive targets. It seems unlikely that any but the best financed and most technologically sophisticated terrorist groups would be able to cause more than isolated damage.

---

\* Note: On February 6, 1972, the Black September groups blew up two gas processing plants in Rotterdam which represents the only energy-related attack by the seventeen largest terrorist organizations between 1968 and 1978. More significant was the attack on South Africa's SASOL plant (synthetic oil) this year by Black Nationalists.

Table 1.4-141

INCIDENTS OF ENERGY-RELATED TERRORISM

FACILITY	DATE/REFERENCE	WHO	REASON	DAMAGE	INTERRUPTIONS
transmission towers owned by Public Service Elec. & Gas Co., Edar Grove, NJ	NYT, 11-6-68, 40:1	unknown	unknown	tower footing damaged	none
Oil Co. pipeline Oakland, CA	NYT, 3-19-69, 28:4	unknown	unknown	fuel carried by creek to nearby community; three injuries	none
transmission lines in Colorado	NYT, 4-16-69, 54:1	"campus revolu- tionary"	electricity ran to local defense plants	not available	not available
inery owned fumble Oil inden, NJ	NYT, 1-27-70, 1:5 and 56:4	United Socialist Revolutionary Front	get political prisoners freed	"millions of dollars" to four units	production halted but no interruption
transformer in Puerto Rico	NYT, 1-1-75, 36:1	assumed Puerto Rican Nationalists	assumed in pro- test of visit by Kissinger and Rockefeller	app. \$100,000	east part of island without power
line in Puerto Rico	same as above	same as above	same as above	not available	not available
transmission towers near Oakland owned by PG&E	LAT, 3-22-75, I, 25:4	New World Liber- ation Front (NWLF)	rate protest	slight	none
station owned by PG&E near San Jose, CA	LAT, 4-19-75, I, 25:4	NWLF	rates	app. \$15,000	12,000 homes without power
station owned Seattle Light Seattle, WA	NYT, 1-2-76, 45:2	George Jackson Brigade	not available	not available	2,000 without power
PG&E substation San Jose, CA	NYT, 1-2-77, 17:1	NWLF	rates to low- income consumers	not available	not available
PG&E substation Cupertino, CA	LAT, 1-28-77, I, 3:6	NWLF	same as above	"substantial"	power out to 21,000 for 30 minutes
PG&E substation Oakland, CA	LAT, 4-16-77, 28:3	NWLF	same as above	not available	power out to 5,000
PG&E transformers Sonoma, CA	LAT, 4-19-77, I, 2:5	NWLF	same as above	not available	power out to 8,000
Alaska Oil Pipeline	NYT, 7-29-77, 7:1	local miner	"disgruntled by line's construc- tion"	pipe ok, insula- tion damaged	flow halted for re- pairs
PG&E substation Sausalito, CA	NYT, 8-30-77, 10:6	assumed NWLF	rates	not available	blackout in Sausalito
Alaska Oil Pipeline	NYT, 2-18-78, 18:6	unknown	unknown	1" hole in line; 8,000 barrels lost; unassessed environmental damage	none
PG&E substation Concord, CA	LAT, 3-16-78, I, 23:3	NWLF	rates	not available	power out to 50,000

## Natural Disasters and Vulnerability (1.5)

Severe weather conditions and other natural disasters, such as earthquakes, can create paralyzing conditions conventional energy facilities, grids, and transportation/distribution systems.

Severe winter weather, such as that experienced in 1976-77, creates such conditions. During that winter, barge traffic was blocked by iced-over canal conditions, power lines froze and toppled, truck movements carrying fuel, food and vital commodities slowed to a virtual standstill. These conditions affected the entire northeastern U.S. and temporarily crippled vital energy transportation systems. Other natural disasters such as floods, droughts, tornadoes, and hurricanes have caused havoc to energy and utility systems.

Other more far-reaching disasters, such as major earthquakes, are highly disruptive events which can cause long-lasting damage to energy systems. A recent National Security Council (NSC) committee study on earthquake vulnerability estimates the probability of a massive California earthquake to be 50 percent or higher within the next 30 years. Such an earthquake could have a magnitude in excess of 7.0 on the Richter scale.

The NSC study estimates that a major earthquake would cause between \$15 to \$70 billion in damage depending on which area of the state was affected and other conditions such as time of day. For an earthquake of 7.5 magnitude striking the Newport-Inglewood fault in the immediate Los Angeles area, damage would be in the \$70 billion range and fatalities would range from 4,000 to 23,000.<sup>42</sup>

According to the NSC study, "most systems for communications, transportation and water and power generation and distribution are as a whole resistant to failure, despite potentially severe local damage, because of their network-like character. These systems would suffer serious local outages, particularly in the first several days after the event, but would resume service over a few weeks to months. The principal difficulty will be the need for these systems in the first few days after the event when life-saving activities will be paramount."<sup>43</sup>

Region IX of the Federal Emergency Management Agency (FEMA) has prepared a draft Earthquake Response Plan for the San Francisco area, and is now working with the State of California on plans for a potentially disastrous Southern California earthquake. The NSC study points out that as such plans are developed, the possibility of predicting such a major earthquake may increase. If this happens, "decisions (to act on such a prediction) may include such possibilities as the mobilization of National Guard and Department of Defense resources prior to the event, the imposition of special procedures or drills at potentially hazardous facilities such as nuclear reactors or dams..."<sup>44</sup>

The NSC study notes that:

All major transportation modal systems be affected: highways, streets, and bridges, mass transit systems,



railroads, airports, pipelines and ocean terminals. There will, however, be major variances in losses among the modes. From a purely structural standpoint the more rigid and/or elevated systems such as railroads and pipelines which cross major faults on an east-west axis will incur the most extreme damage with initial losses approaching 100 percent. Other major systems such as highways, airports and pile-supported piers at water terminals with better survivability characteristics will fare much better with damage generally in the moderate range of 15-30 percent. During the 1971 San Fernando earthquake, numerous freeway overpasses collapsed. Improvements in design for new overpasses and a program of retrofitting for older overpasses have moderated this problem, but significant damage must be anticipated to unmodified structures. These transportation facility loss estimates are stated in terms of immediate post-quake effects. They do not reflect the impact of priority emergency recovery efforts or the inherently significant degree of redundancy and flexibility in the transportation system. Consequently, there will remain an unquantified but significant movement capability. Finally, these loss estimates do not take into account the questions of availability of essential supporting resources, particularly petroleum fuels, electricity and communications. In the initial response phase, these could prove to be the most limiting factors in the capability of the transportation system.<sup>45</sup>

Certainly, the potential for widespread disaster is considerably less in the case of a major earthquake than with a nuclear attack or major sabotage event affecting national energy systems. However, as this new NSC study confirms, disruption is heightened because of the increasing centralization and complexity of key energy and transportation systems. In the case of California, an additional level of precaution may be called for because of the location of five coastal nuclear power plants. (Only one is licensed, but four plants are either under construction or ready for licensing.) Even if these plants are not directly affected by an earthquake, disruption in the grip may prevent them from delivering crucial power to affected areas for lengthy periods.

## Energy and War: Historical Lessons (1.6)

The concept of targeting energy facilities during times of war is not new. Enemy energy sources have been attacked in recent conflicts including World War II, Korea, Vietnam, the 1973 Middle East conflict and the 1980 Persian Gulf war. The World War II examples of Germany and Japan offer a clear-cut demonstration of the strategic disadvantages of centralized vs. decentralized energy systems.

### The German Example: Centralization (1.6-1)

Electric power was, together with coal, the most vital part of the German energy system, and for a number of reasons it was even more vulnerable to attack.

In 1933 the installed capacity of electric motors represented 73.2 percent of all industrial motive power in Germany. By 1944 probably 80 percent of the motive power was derived from electrical sources. Although most of the electricity consumed by German industry was used to produce mechanical power, i.e., to run electric motors, a significant proportion was used in industrial electric ovens and in industrial electrolytic processes, the principle end products of which were aluminum, magnesium, chlorine, and caustic soda and potash. Finally, electricity was indispensable for the synthetic production of oil, rubber and nitrogen.<sup>46</sup>

Coal was the primary source of electric power generation in Germany. In 1941, 80.2 percent of the electricity produced by the public power plants was obtained from coal, and the remaining 19.8 percent from water power, with about twelve percent coming from run-of-river or low-head hydroelectric plants and eight percent from high-head hydro plants. For the private, industrial electric power plants, water was even less important. Coal again ran about 80 percent of the plants, gas about ten to fifteen percent and water about five percent.<sup>47</sup>

Of the 80.2 percent of public plant electricity generated from coal, 44.4 percent was from brown coal and 35.8 percent from bituminous coal. Because brown coal has a low heating value, and hence would make transportation costs uneconomic, brown coal stations tend to be located either directly on or close to the coal fields from which they are supplied. Such stations are usually public, rather than private, except when an industry is also located in or near the field and has its own captive power plant. Bituminous coal stations on the other hand, are generally situated close to their potential consumer, i.e., either near or in large cities or close to the industrial plants which they service.

In 1939 there were 8,257 electric generating stations in Greater Germany, including both public and private plants. Although most of the stations were small, the greater part of the capacity was derived from a relatively small number of large stations. For example, 79.6 percent of all the stations had capacities of 1,000 kv-a or less, but the 113 stations (representing only 1.4 percent of the total) having over 50,000 kv-a capacity produced 56.3 percent of all the current generated, and accounted for 51.0 percent of the electric power capacity. The 416 stations having over 10,000 kv-a capacity, though representing only 5.0 percent of all the public and private stations, accounted for four-fifths (81.9 percent) of the power generated, and constituted 75.8 percent of the capacity.<sup>48</sup>

Although this concentration of electric power production was much smaller than the notable plant concentrations in other industrial fields, it was nevertheless a significant concentration for an industry as widely dispersed as electric power and made the industry vulnerable to wartime attack. Following the start of the war, there was a substantial increase in the number of giant private generating plants which were constructed in connection with the expanding synthetic oil and synthetic rubber industries which were large consumers of electric power.

Of the 8,257 generating stations in Germany, only about one-fourth (23.8 percent) were public stations. However, these 1,964 stations accounted for slightly more than half (55.8 percent) of the total power production, as well as slightly more than half (57.9 percent) of the generator capacity. Private generating plants, though numerous, were for the most part, small, while the public plants, though fewer in number, tended to be larger. The public power stations having the largest capacities produced the overwhelming bulk of the public power. For example, the 192 public stations having more than 10,000 kv-a capacity produced 91.1 percent of the power generated by all public plants and accounted for 88.7 percent of the public capacity. Although the private plants followed the same pattern, they did so to a lesser extent, since only 70.3 percent of the private power was produced by stations falling in the same capacity size group.<sup>49</sup>

Geographical concentration also existed, and while electric generating stations were located throughout Germany, there were five main concentrations of generating capacity, each of which was dominated by one or more of the large public plants. Each area also had a number of large private power plants. The public generating plants were interconnected by means of the various transmissions and distribution networks forming the national grid system. Beginning with the war, most of the large private industrial power stations having a surplus of power were tied into the public utility network. Early in the 1930s the utilities had begun to construct interconnections of generating stations, and subsequently from the

main substations, in order to supply areas in an ever widening circle. The existence of the national grid caused the Allies to question the vulnerability of the electric power system: "The mobility of electric power, except under limited conditions... would permit the Germans to spread the loss at any point throughout the region attacked, and probably throughout German."<sup>50</sup>

In contrast to this assumption, however, was the concern of German officials that the Allies would recognize the strategic vulnerability of Germany's centralized power system. Dr. Roser, Chief Electrical Engineer for RWE, Germany's largest utility, expressed this concern when he stated, "The war would have finished two years sooner if you (the Allies) had concentrated on the bombing of our power plants earlier... . Your attacks on our power plants came too late. This job should have been done in 1942. Without our public utility power plants we could not have run our factories and produced war materials. You would have won the war then and would not have had to destroy our towns. Therefore, we would now be in a much better condition to support ourselves. I know the next time you will do better."<sup>51</sup>

Underscoring the surprise of German officials that the Allies did not target and destroy power plants was Reichminister Albert Speer's (Minister for Armament and War Production) comments, "I think that attacks on power stations, if concentrated, will undoubtedly have the swiftest effect; certainly more quickly than attacks against steel works, for the high quality steel industry, especially electro-steel, as well as the whole production of finished goods and public life, are dependent upon the supply of electric power... . The destruction of all industry can be achieved with less effort via power plants."<sup>52</sup> Agreeing with Speer, Reichmarschall Hermann Goering, Commander of German Air Forces, elaborated, "We were very much afraid of an attack on German power plants. We had ourselves contemplated such an attack in which we were to destroy power plants in Russia."<sup>53</sup> Figure 1.6-1 shows the effects on production from destruction of German electrical plants in Allied raids.

#### The German Example: Synthetic Fuels (1.6-2)

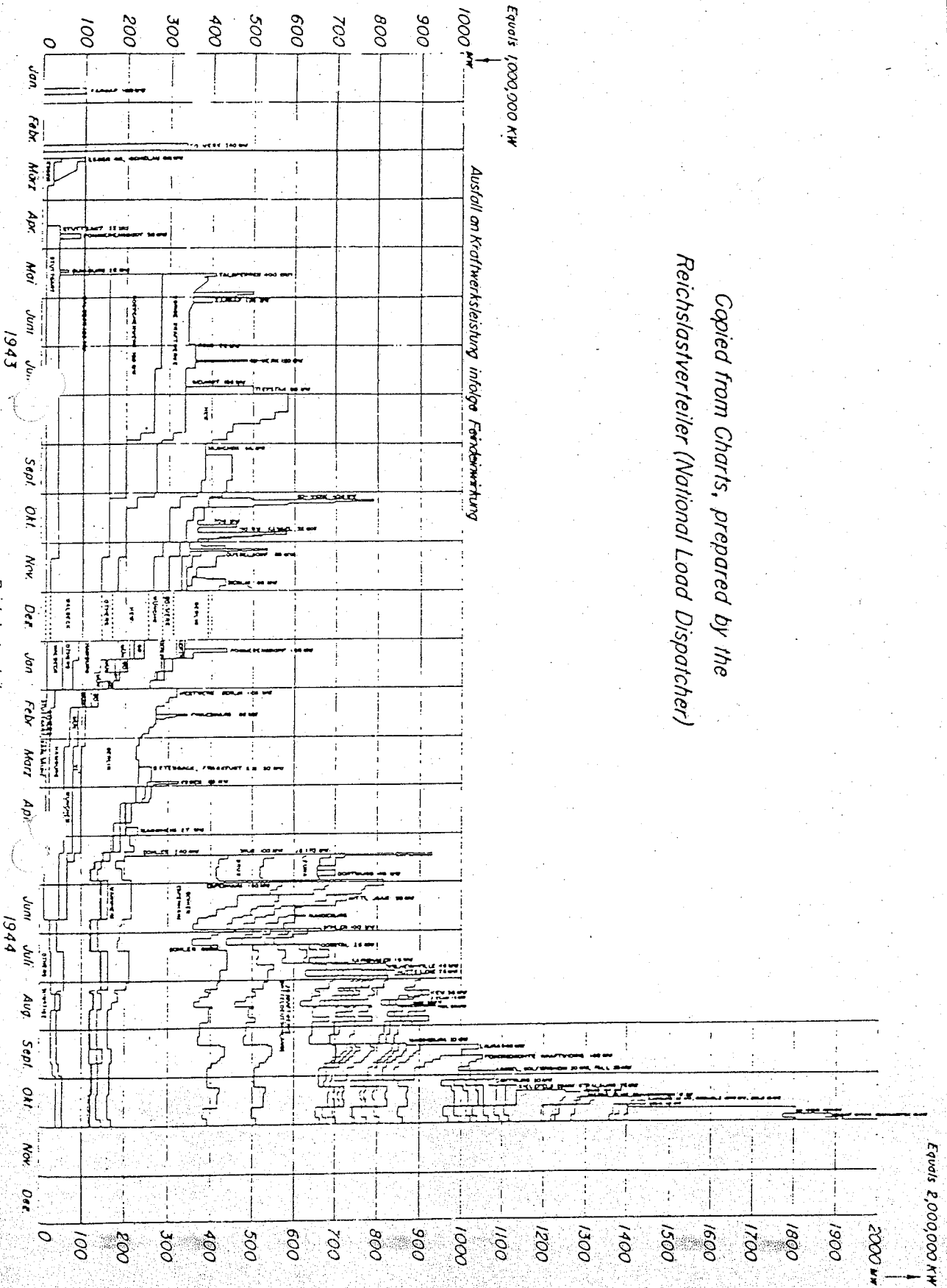
Not only did coal provide the major fuel resource for the production of electricity, but it was also the basis upon which the synthetic fuel industry developed. Germany developed a number of technologies to utilize synthetic fuels from fossil and biomass sources for automotive and other uses. Before war broke out, the Germans had pioneered a number of techniques to use liquefied gas (propane, butane) from the synthetic fuels plants. By 1941, over 150,000 vehicles were running on producer gas in the Reich and occupied territories. The fuel supply for this gas was a combination of coke, anthracite, charcoal, coal, peat and other sources.

Following a directive from Goering, plans were made to provide for an output of eleven million tons annually by 1944, mainly from a major expansion of the synthetic oils plants, and chiefly from the hydrogenation process. Eventually

Figure 1.6-154

LOSS OF GERMAN POWER PLANT CAPACITY DUE TO ALLIED ACTION

Copied from Charts, prepared by the Reichslastverteiler (National Load Dispatcher)



eighteen hydrogenation plants and nine Fischer-Tropsch plants went into production.\* Synthetic oil production expanded rapidly during the war, and an enormous amount of money and resources were devoted to this expansion. Annual production amounted to 1.6 million tons (1.5 billion kg) in 1938, 2.3 (2.1 billion kg) in September 1939, 3.3 (3 billion kg) in 1940, 4.1 (3.7 billion kg) in 1941, 4.9 (4.4 billion kg) in 1942, 5.7 (2.6 billion kg) in 1943, and had reached 6.0 million tons (2.7 billion kg) annually by the end of 1943. By early 1944, synthetic oil production accounted for more than half of the German oil supply.

The three major oil products of the synthetic process were aviation gasoline, motor gasoline and diesel oil. The hydrogenation process produced mainly aviation gasoline, with large amounts of motor gasoline and diesel fuel. About 90 percent of all Germany's aviation gasoline was produced by the hydrogenation process. Hydrogenation and Fischer-Tropsch produced 32 percent of the motor gasoline, 36 percent of the diesel oil, and a total of 39 percent of all petroleum products.

At the midpoint of the war, the German goal of equipping a quarter of a million vehicles to use alternative fuels was apparently reached. By March 1944, more than 80 percent of large vehicles had been equipped to use alternative gaseous, liquid and solid fuels. German filling stations were established to dispense wood chips and alternative fuels; special spare parts inventories were developed as well. Special "Imbert" gas units were utilized on automobiles and trucks. To maximize usage, the Reich granted a subsidy for vehicle conversion, ranging from RM (Reichsmark) 400 to RM 1,000 per vehicle.<sup>55</sup>

The synthetic fuel industry was concentrated near the major coal mines in the Ruhr Valley, and thus were susceptible to enemy attack. Because the Allies' prime targets were initially strategic military facilities, they failed to take advantage of Germany's energy vulnerability until very late in the war. When the Allies did destroy Germany's main synthetic fuel and electricity producing plants, the German war economy was essentially incapacitated. Figure 1.6-2 illustrates the dramatic effect of Allied bombing on synfuel production in Germany in 1944.

The history of the Allied bombing attacks upon Germany in World War II demonstrates that with the growing interdependence of energy intensive economies, the more concentrated and centralized the energy sources, the more vulnerable the economy to a wartime attack. The instigation of attacks upon the energy production and transportation systems brought rapid and excessively damaging results, particularly with the attacks upon the means to transport coal and produce synthetic fuels.

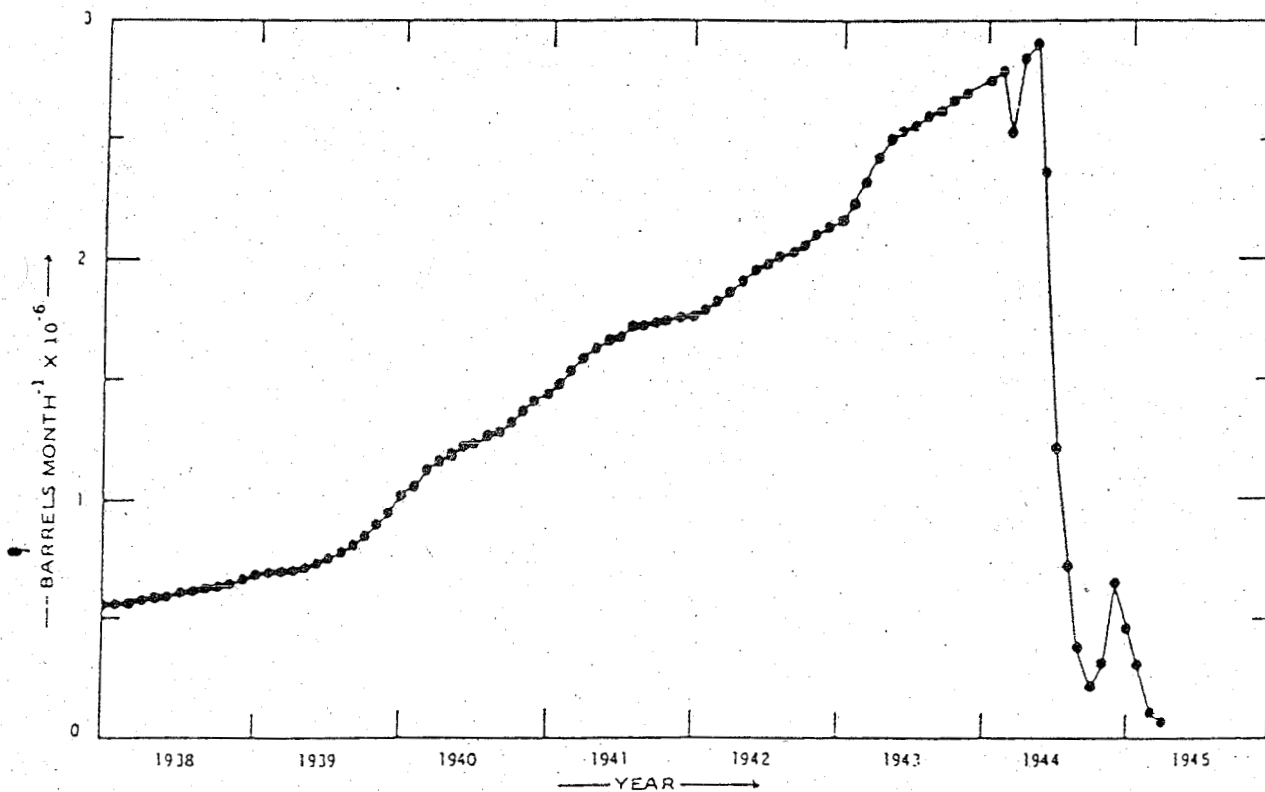
---

\* The Fischer-Tropsch process for producing oil from coal was developed in the 1920s in Germany. Modifications of this design are still widely used (such as the coal/synfuel plants in South Africa), in which hydrocarbons are synthesized from coal-derived hydrogen and carbon monoxide.



Figure 1.6-2<sup>56</sup>

AIR RAID DAMAGE TO GERMAN SYNTHETIC FUEL PRODUCTION



The Japanese Example: Decentralization (1.6-3)

Japan, on the other hand, had a very decentralized energy network during World War II, making her power-generating stations a very low-priority target. According to the U.S. Strategic Bombing Survey (Pacific), "the electric power system of Japan was never a primary strategic target"<sup>57</sup> because most of the power requirements of Japan were "so numerous, small and inaccessible that their destruction would have been impractical, if not impossible."<sup>58</sup>

As Table 1.6-1 illustrates, the total air raid damage to the Japanese utility grid consisted of bombing hits on 35 power plants. Of this, only nine hydro plants were hit, and the total damage to Japan's hydro-electric capacity was .27 percent of the total air raid damage. Over 99 percent of the damage was sustained by attacks on conventional, large steam plants. Figure 1.6-3 illustrates the contribution of small hydro and steam to Japan's total electrical generation capacity during the war. Figure 1.6-4 contrasts dramatically the extent of the electrical capacity loss from Allied air raids on Japanese steam plants (large and centralized) vs. that from small hydro plants (small and dispersed).

Table 1.6-160

TOTAL AIR AID DAMAGE TO GENERATING FACILITIES  
OF THE JAPANESE UTILITY SYSTEM

<u>Name of Company</u>	<u>Hydro or Steam</u>	<u>Generating stations damaged</u>	<u>Loss of capacity because of air damage (kw)</u>	<u>Percent of total loss of capacity</u>	<u>Amount of damage in yen</u>	<u>Percent of total damage</u>
Nippon Hassoden	Hydro	4	22,700	1.76	208,200	0.26
	Steam	20	1,249,250	96.92	78,497,600	96.46
	Total	24	1,271,950	98.68	78,705,880	96.72
Kanto Haiden	Steam	1	9,500	.74	690,067	.85
Chugoku Haiden	Steam	1	4,500	.35	1,780,000	2.19
Shikoku Haiden	Steam	1	0	0	26,758	.03
Kyushu Haiden	Hydro	3	0	0	9,100	.01
	Steam	1	3,000	0.23	142,900	.18
	Total	4	3,000	.23	152,000	.19
Hokkaido Haiden	Hydro	2	0	0	5,900	.01
	Steam	2	0	0	14,000	.02
	Total	4	0	0	19,000	.03
Total	Hydro	9	22,700	1.76	223,280	.27
	Steam	26	1,266,250	98.24	81,151,325	99.73
	Total	35	1,288,950	100.00	81,374,605	100.00

Figure 1.6-361

MAJOR SOURCES OF JAPANESE ELECTRICITY GENERATION

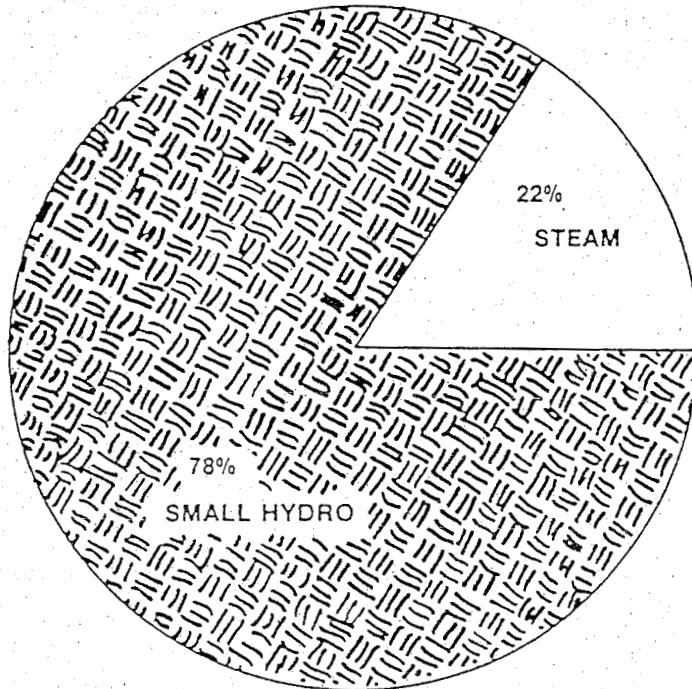
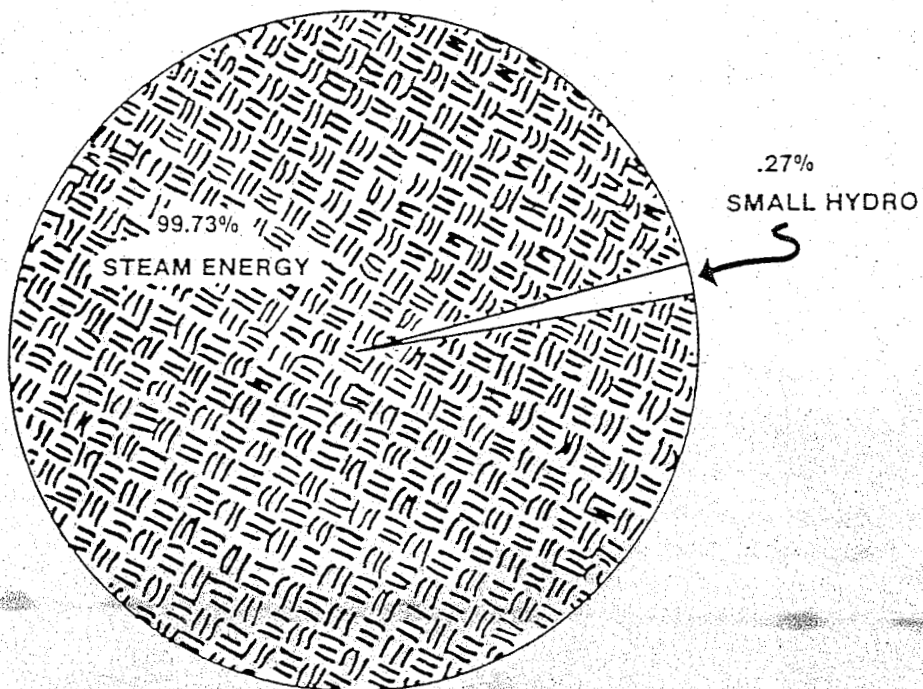


Figure 1.6-462

PERCENT AIR RAID DAMAGE TO JAPANESE  
SMALL HYDRO AND STEAM ELECTRICITY PRODUCTION



In 1944, the total generating capacity on the home islands was 10,120,000 kilowatts (10,120 MW). Generation in the peak war year, 1943, was 38.4 billion kilowatt-hours from all sources including utility, railway and industrial facilities. Water power from small hydro plants provided 78 percent of the total electricity in the system, with the remainder of use supplied by steam plants (mostly antiquated coal plants). During the war the largest hydroelectric plant in Japan was 165 MW plant on the Shinanogawa River. This plant supplied only 2.7 percent of annual electrical consumption.<sup>59</sup>

Japan was never able to increase the overall level of electrical system expansion during the war. However, the U.S. electrical war economy grew at an annual rate of 33 percent (compared to the Japanese electrical system growth of only three percent per year). The Strategic Bombing Survey points out that "Japan could, with relative ease, have increased her production of kilowatt hours over the 1943 level—so far as the capability of her predominantly water-driven generation system was concerned."<sup>63</sup> However, supplies of necessary materials were diverted to war effort, rather than increasing the size of the electrical system.

In its formal conclusions, the Allied Bombing Survey stated:

Most of the power requirements of Japan, however, come from hydro generating plants, which are so numerous, small and inaccessible that their destruction would be impractical, if not impossible. If their supply could be eliminated or drastically curtailed by some other means, electric power supply could be reduced to a point where the shortage would assume economic importance. It has been shown that neither the transmission nor the distribution system is, of itself, vulnerable."<sup>64</sup>

#### Vulnerability of Facilities Since World War II (1.6-4)

Since World War II, power plants and electrical facilities have become prime targets.\* During the Korean war, the United States made an early decision not to bomb large hydroelectric dams along the Yalu River, but reversed the decision two years later in 1952. As Bennett Ramberg points out, "the decision was reversed...when negotiations deadlocked and destruction of the plants seemed necessary to hasten the war's conclusion and to make more difficult the repair work the Communists were doing in small industrial establishments and railway tunnels."<sup>65</sup>

During the Vietnam war, the United States destroyed some electrical facilities, but this was never a major strategic commitment. As with Japan during World

\* In the early days of the Cold War, during the Berlin crisis (1948-49), the "Joint Outline War Plan," recently declassified by the U.S., called for a potential bomber strike against the Soviet Union with 150 nuclear weapons. Code named "Trojan," the plan's top priority was elimination of Soviet refineries, especially those producing aviation fuel, with the objective of eliminating fueling of the Soviet Armed Forces.<sup>66</sup>

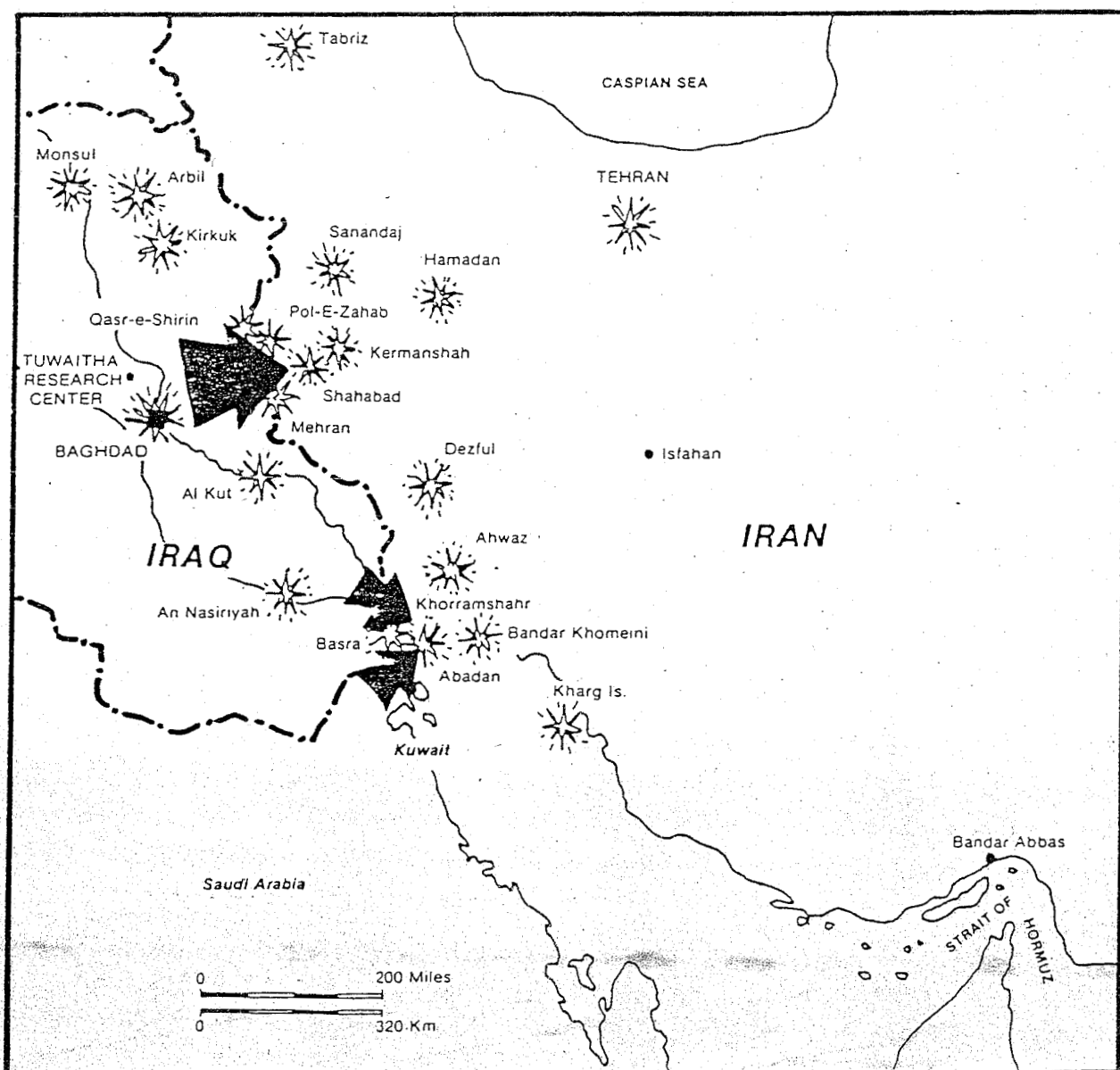
War II, most power plants in Vietnam were too small and scattered to be primary targets. Decentralization of the electrical system preserved substantial capacity.

In the Middle East, during the 1973 war, Israeli warplanes bombed power stations at Damascus and Homs, Syria, "to subdue Syrian military activity and to deter other countries from entering the conflict."<sup>67</sup>

Power plants and oil refineries have been targeted, most recently during the 1980 war between Iran and Iraq. The Abadan oil refinery complex at Kharg Island was bombed. This lesson in vulnerability affects the entire industrial world, as critical oil supplies must pass through the narrow Straits of Hormuz currently threatened by military actions.

Figure 1.6-568

THE EXTENT OF THE FIGHTING



In fact, the Persian Gulf war may prove to be a threatening indicator to the future, as most primary energy targets, ranging from refineries to key oil fields to the Iraqi nuclear research center, Tuwaitha, were selected for bombing forays. The September 30, 1980 attack on the French-built Osirak and Isis research reactors of the Tuwaitha facility raised the spectre of radioactive fallout from conventional bombing. Although officials of the Nuclear Regulatory Commission contend "that there (is) very little risk that bombing a research reactor would ever cause a significant fallout problem" a worst-case scenario allows for radioactive pollution to spread at least a mile or two from the reactor.<sup>69</sup>

"Bombs, presumably delivered by Iranian pilots, hit the research site about ten miles from the center of Baghdad. They damaged an auxiliary building and forced the French technicians working on the project to leave. The attack did not damage the reactors, but it did shut the program down indefinitely."<sup>70</sup>

The only missing element in this Middle East duel was the presence of nuclear-tipped warheads.



## Nuclear Weapons and Their Effects (1.7)

With the advent of the bombing of Hiroshima, the scope of modern warfare changed radically. After World War II, the subsequent development of the hydrogen bomb and the spread of nuclear weapons technology to other superpowers has expanded the modern battlefield to the entire industrial world. Improved missile technology makes it possible to deliver nuclear warheads launched from submarines to targets in a few minutes' time. Table 1.7-1 illustrates the current inventory of strategic nuclear weapons in the arsenals of the Soviet Union and the United States. These arsenals are divided into categories which include Intercontinental Ballistic Missiles (ICBMs), Submarine-Launched Ballistic Missiles (SLBMs), Long-range Bombers, and nuclear, missile-equipped submarines.

Table 1.7-1<sup>71</sup>

### U.S. AND SOVIET STRATEGIC NUCLEAR FORCES (1980 TOTALS)

<u>System</u>	<u>U.S.</u>	<u>U.S.S.R.</u>
ICBMs	1054	1398
SLBMs	600	950
Long-range bombers	348	156
Nuclear-powered, ballistic missile-equipped submarines	37	63
Total long-range bombers and missiles	2002	2504
Total warheads on bombers and missiles, official U.S. estimates	9200*	6000*

\* 1 January, 1980

For the past several years, the Soviet Union has increased its production of nuclear weapons and is reaching parity with the United States in terms of intercontinental power. In terms of actual megatonnage, the Soviet Union is somewhat ahead of the U.S. As one recent analysis summarized the arms race:

For several years Russia has outreached the United States in most measures of nuclear strength--megatons of exposure power (1 megaton = 1 million tons of TNT), numbers of missiles and the total weight that can be lifted to the target. Only in numbers of warheads has the United States remained ahead.

But even this last American advantage is rapidly disappearing as the Russians deploy large numbers of independently targetable reentry vehicles on their big new missiles. The raw warhead totals do not tell the whole tale anyway. A much higher percentage of America's warheads are carried by bomber bombers and submarine launched missiles. The bombers have a much smaller chance of getting through than missiles do, and the submarine missiles are not only much less accurate than the land-based ones—not accurate enough to destroy the other side's missile silos—but also less readily usable (only about half the American missile submarine fleet is at sea and ready for action at any given time).<sup>72</sup>

A nuclear attack on one of our highly concentrated industrial, military or population centers would create massive damage, both in the short-run and long-run. The first two effects of a nuclear detonation would occur within seconds (and minutes) following the explosion. These effects are blast and thermal radiation.

Blast is overpressure which crushes buildings and other structures; it follows a scale law, proportional to the cube root of the yield of the nuclear weapon. The blast pressure wave is a function of the size of the bomb, height of the burst, atmospheric conditions, and distance from the center of the burst. Figure 1.7-1 illustrates the effect of a one-megaton nuclear explosion over the city of Detroit at a detonation altitude of 6,000 feet.

A detonation of this magnitude (one megaton explosion at 6-8,000 feet) would create extensive blast damage between ground zero to six miles. The effects are summarized in Table 1.7-2.

Thermal radiation or the heat from the nuclear explosion accounts for approximately one-third of the energy released by the explosion. The heat wave from the explosion precedes the blast wave by a few seconds; a one-megaton explosion would cause flash-blindness up to 53 miles on a clear night. Such an explosion can cause first-degree burns at distances up to seven miles, second-degree burns (serious blisters and permanent scars) up to six miles away, and third-degree burns (which destroy skin tissue) up to five miles away. According to the Congressional Office of Technology Assessment: "Third-degree burns over 24 percent of the body, or second-degree burns over 30 percent of the body, will result in serious shock, and will probably prove fatal unless prompt, specialized medical care is available. The entire United States has facilities to treat 1,000 or 2,000 severe burn cases; a single nuclear weapon could produce more than 10,000."<sup>75</sup>

Thermal radiation, in addition to seriously wounding people in the critical pathway of the explosion, will cause firestorms such as those experienced during World War II in Hamburg, Dresden and Hiroshima with a resulting grave loss of life. Along with thermal radiation, nuclear explosions create electromagnetic pulse (EMP), an electromagnetic wave which results from secondary reactions occurring when gamma radiation is absorbed in the air or ground. EMP creates a substantially

Figure 1.7-173

DETROIT, 1 MT AIR BURST

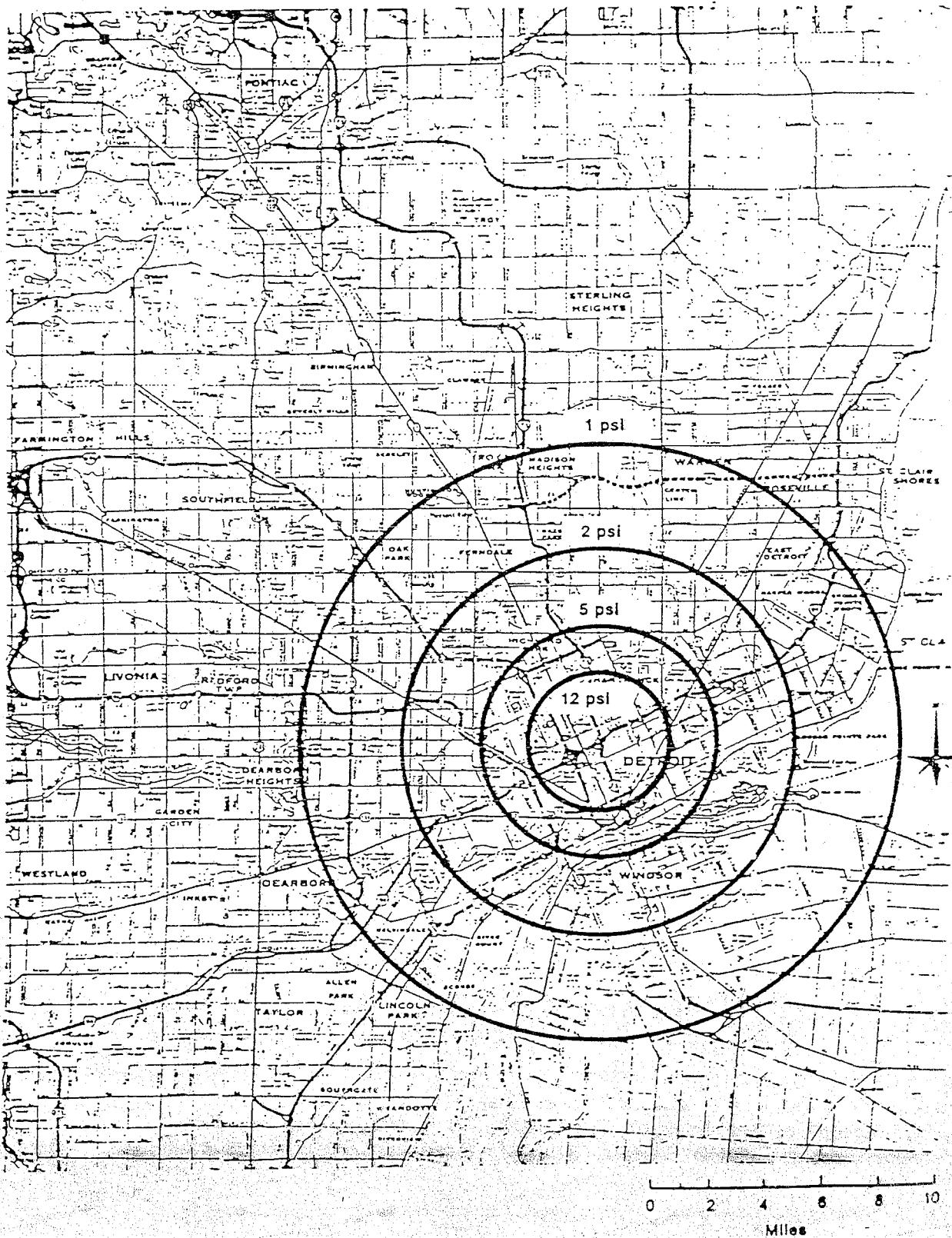


Table 1.7-2<sup>74</sup>

BLAST EFFECTS OF A 1 MT EXPLOSION 8,000 FT. ABOVE THE EARTH'S SURFACE

Distance from ground zero (stat. miles) (kilometers)		Peak over pressure	Peak Wind velocity (mph)	Typical blast effects
.8	1.3	20 psi	470	Reinforced concrete structures are leveled.
3.0	4.8	10 psi	290	Most factories and commercial buildings are collapsed. Small wood-framed and brick residences destroyed and distributed as debris.
4.4	7.0	5 psi	160	Lightly constructed commercial buildings and typical residences are destroyed; heavier construction is severely damaged.
5.9	9.5	3 psi	93	Walls of typical steel-frame buildings are blown away; severe damage to residences. Winds sufficient to kill people in the open.
11.6	18.6	1 psi	33	Damage to structures; people endangered by flying glass and debris.

higher electric field strength than an ordinary radio wave and disappears in a fraction of a second. Although EMP is not necessarily dangerous to human life, it is capable of destroying (or rendering inoperative) sensitive electronic equipment and components of electrical energy systems. EMP can disrupt electrical grids by disrupting enough component parts and circuitry to cause the immediate failure of entire electrical grid systems.

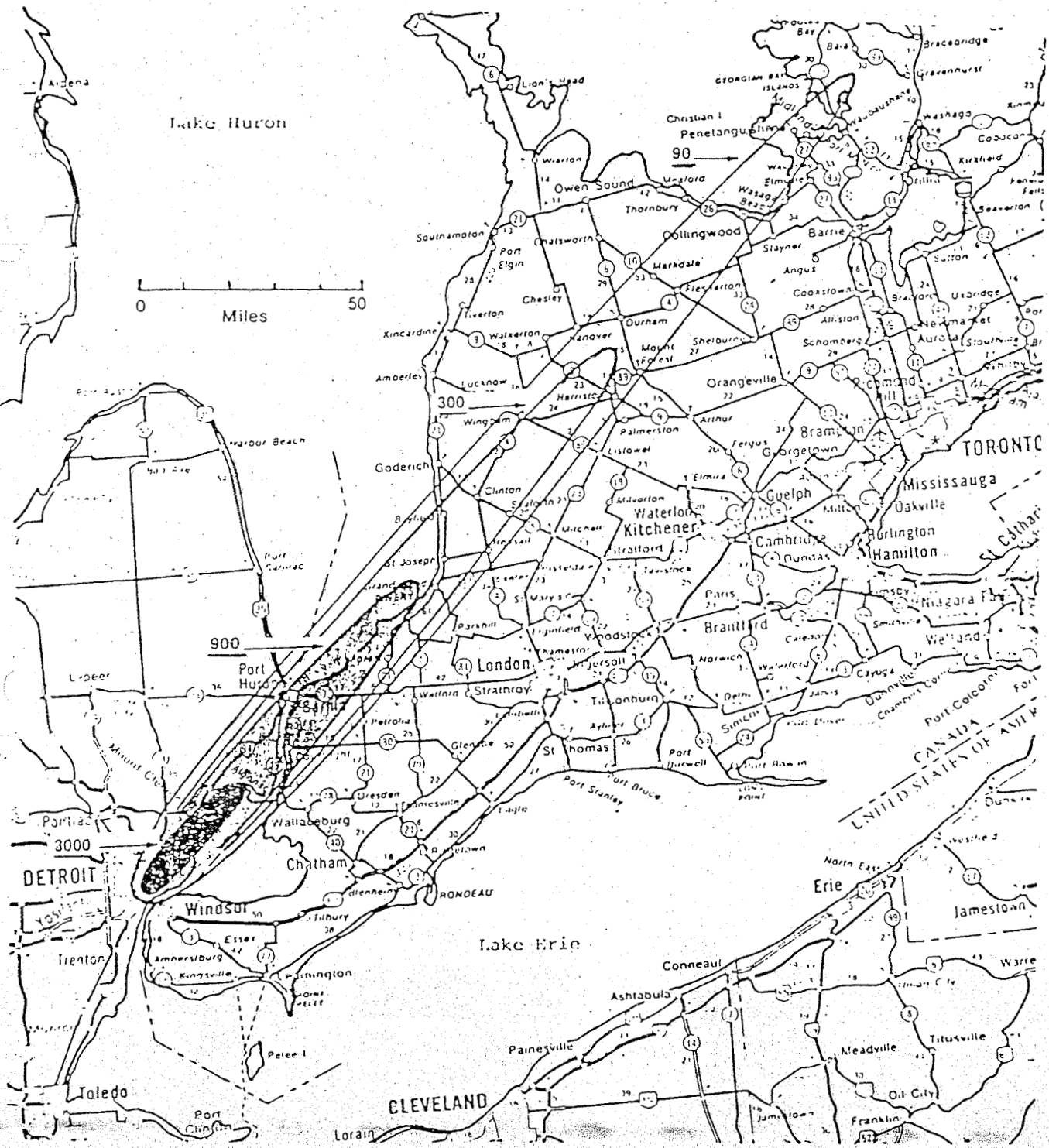
The third, and most long-lasting effect of a nuclear detonation, is radioactive fallout. Fallout, or the radioactive particles caused by irradiation of material swept up into the nuclear cloud, immediately falls near the explosion within a radius of ten miles and is carried into the atmosphere within the mushroom cloud. Figure 1.7-2 illustrates the fallout "footprint" from the hypothetical Detroit (one-megaton) explosion. This illustration shows the effects accumulated over a one-week period. High radiation levels, capable of causing death and serious injury, extend up to 200 miles from the blast center. Since radioactive materials have varying "decay" rates, some of the more toxic materials will be somewhat neutralized within a period of days and weeks. However, many of the radioactive materials will remain toxic for lengthy periods, increasing the incidence of cancer for generations.

Substantial work has been performed by predecessor agencies of the Federal Emergency Management Agency (FEMA) (for example, the Office of Civil Defense - OCD, and the Defense Civil Preparedness Agency - DCPA) on the consequences of nuclear attacks on energy facilities.\* Recently, the Office of Technology

\* Some major reports include: (1) M. Stephens, "Minimizing Damage to Refineries from Nuclear Attack, Natural and Other Disasters," OCD Report, Office of Oil and Gas, U.S. Dept. of the Interior, Feb. 1970; (2) "Critical Industry Repair Analysis: Petroleum Industry," OCD Report, Advance Research, Inc., Wellesley Hills, Mass., 1964; (3) "Protecting Industrial Resources Against Nuclear Attack: Interim Report of an Economic Analysis," OCD Report, Institute for Defense Analysis, Arlington, Va., 1965.

Figure I.7-276

"FOOTPRINT" OF HYPOTHETICAL NUCLEAR ATTACK ON DETROIT



Main Fallout Pattern—Uniform 15 mph Southwest Wind (1-Mt Surface Burst in Detroit).  
(Contours for 7-Day Accumulated Dose (Without Shielding) of 3,000, 900, 300, and 90 Rem.)

Assessment, working with DCPA, presented an analysis of a "limited" bombing attack by the Soviet Union on selected U.S. industrial targets. OTA limited the attacking force to ten Soviet ICBMs (SS-18 missiles carrying multiple independently targetable reentry vehicles (MIRVs) with eight one-megaton warheads on each missile). Petroleum refineries were selected for this reason:

Given the limitation of ten ICBMs, the most vulnerable element of the U.S. economy was judged to be the energy supply system. The number of components in the U.S. energy system forces the selection of a system subset that is critical, vulnerable to a small attack, and would require a long time to repair or replace. OTA and the contractor jointly determined that petroleum refining facilities most nearly met these criteria. The United States has about 300 major refineries. Moreover, refineries are relatively vulnerable to damage from nuclear blasts. The key production components are the distillation units, cracking units, cooling towers... . Storage tanks can be lifted from their foundations by similar effects, suffering severe damage and loss of contents and raising the probabilities of secondary fires and explosions.<sup>77</sup>

In this attack scenario, the eighty one-megaton weapons carried on the ten SS-18 missiles are used to destroy 77 U.S. refineries having the largest capacity (with the extra three warheads used to destroy the largest refineries within the original attack "footprints"). If all of the weapons are air burst, and given the proximity of refineries to large cities, over five million people are killed immediately. If the weapons are ground burst, just over three million are killed.

In addition to destruction of the refineries, many ports would be heavily damaged, thus crippling U.S. ability to import oil to make up for the loss of domestic capacity. Further, other industries located near refineries would be damaged or destroyed such as the petrochemical industry which is located near refineries and uses oil for feedstock.

The OTA study concludes that even though a third of the nation's refining capacity would survive this attack, "this does not mean that everyone would get a third of the petroleum they did before the war." Severe rationing would be imposed, limiting most fuel to military, agricultural, railroad, police, and local government service use. "The demise of the petroleum industry would shatter the American economy," the study emphasizes.<sup>78</sup>

Table 1.7-3 summarizes four potential war scenarios between the U.S. and Russia ranging from an attack on a single city (Detroit) to a full-scale war using much of the available nuclear arsenals.



Table 1.7-379

SUMMARY OF POPULATION AND TARGET DAMAGE  
RESULTING FROM DIFFERENT CLASSES OF NUCLEAR ATTACKS

<u>Description</u>	<u>Main cause of civilian damage</u>	<u>Immediate deaths</u>	<u>Middle-term effects</u>	<u>Long-term effects</u>
Attack on single city (Detroit and Leningrad); weapon or 10 small weapons.	Blast, fire, & loss of infrastructure; fallout is elsewhere	200,000 2,000,000	Many deaths from injuries; center of city difficult to rebuild.	Relatively minor.
Attack on oil refineries, limited to 10 missiles	Blast, fire, secondary fires, fallout. Extensive economic problems from loss of refined petroleum.	1,000,000 - 5,000,000	Many deaths from injuries; great economic hardship for some years. Particular problems for Soviet agriculture and for U.S. socio-economic organization.	Cancer deaths in millions only if attack involves surface bursts.
Counterforce attack; includes attack only on ICBM silos as a variant.	Some blast damage if bomber and missile submarine bases attacked.	1,000,000 - 20,000,000	Economic impact of deaths possible large psychological impact.	Cancer deaths and genetic effects in millions; further millions of effects outside attacked countries.
Attack on range of military and economic targets using large fraction of existing arsenal.	Blast and fallout; subsequent economic disruption; possible lack of resources to support surviving population or economic recovery. Possible breakdown of social order. Possible incapacitating psychological trauma.	20,000,000 - 160,000,000	Enormous economic destruction and disruption. If immediate deaths are in low range, more tens of millions may die subsequently because economy is unable to support them. Major question about whether economic viability can be restored—key variables may be those of political and economic organization. Unpredictable psychological effects.	Cancer deaths and genetic damage in the millions; relatively insignificant in attacked areas, but quite significant elsewhere in the world. Possibility of ecological damage.

## Defense Preparedness and Vulnerability (1.8)

Most national defense measures subscribe to the idea that the best defense is a good offense. Many countries, including the U.S. and the Soviet Union have also addressed national defense concerns with more passive measures. Civil defense (CD) is one way to prepare for nuclear attack by providing populations with shelter and basic human needs in order to reduce the loss of human life. Civil defense could also contribute to the deterrent posture of a state by convincing its enemy that unacceptable damage would not result from a first strike. On the other hand, CD might also encourage provocation by decreasing vulnerability, the premise on which the Mutually Assured Destruction (MAD) Doctrine is based.

In recent years, the civil defense capabilities of the U.S. and the U.S.S.R. have received considerable attention. Studies show that during the late 1970s, the U.S.S.R. spent about twenty times as much as the U.S. for an ambitious civil defense program of shelter upgrading, evacuation planning and public education. It is estimated that in the event of a large-scale nuclear exchange, with a one-week period for population evacuation, the surviving population of the U.S.S.R. would total 90 percent compared to a 40 percent survival rate for U.S. citizens, based on current levels of civil defense preparedness.<sup>80</sup>

Modern proponents of CD believe that improved CD served the same goal as that set for U.S. strategic offensive forces, which is to "preclude enemy domination" and to maximize the "political, economic and military power of the U.S. relative to the enemy in a postwar period."<sup>81</sup> Opponents feel that the value of CD is negligible for both purposes. The difference between these viewpoints is based in differences in assumptions.

The first set of views starts with a conviction that nuclear warheads are weapons of total destruction, the use of which, once initiated, could not possibly be limited or controlled and would make survival of nuclear conflict impossible and the concepts of fighting and winning irrelevant.<sup>82</sup> Those ascribing to this view follow the doctrine of Mutually Assured Destruction, assuming that nuclear warfare able to completely destroy the adversary's society would never take place.

The second view acknowledges a nuclear revolution in warfare but sees the basic laws of warfare as unchanged. Civil defense, therefore, rather than being hopeless and irrelevant, may help the nation to survive and recover. This viewpoint perceives the U.S. need for a national policy that reinforces deterrence. One such defense strategy would be the implementation of an extensive CD program.

The divergence in assumptions regarding deterrence and civil defense kindles the debate over several germane issues:

1. CD and Strategic Equation. Whether CD contributes to strategic equation depends on the perceptions of the actors with respect to the "winability" of war. If CD is perceived to provide long-run protection of populations after an attack, CD, and especially asymmetrical CD protection between adversaries, may encourage one

state to launch a first strike. This view presumes that economic, social and political recovery after a nuclear exchange is likely, and that unacceptable damage would not result from attack. If nuclear war is always perceived as futile for both sides, CD is a wasted effort toward strategic equation.

2. CD and the Credibility of Deterrence. CD may increase deterrent credibility if one state is convinced that the population of another is relatively invulnerable to harm. Hence, asymmetrical CD gives an advantage to the state better prepared to protect populations by providing an added deterrent to enemy attack under the threat of counterattack. On the other hand, opponents argue that CD does not play a significant role toward deterrent credibility due to the minimal contribution CD makes toward actually protecting nations from the dramatic effects of nuclear war.

3. CD and Crisis Coercion. CD advocates posit that states are in better bargaining positions during a crisis if populations are able to relocate. Hence, without relocation capabilities, one state may be "held hostage" by enemy weapons. Opponents believe CD capabilities would not enter into the negotiating process since unacceptable damage to both sides would occur should war break out.

4. CD and Crisis Stability. If one state begins an extensive evacuation of its population from risk areas, another may perceive such action as preparation for an attack and respond with its own preemptive strike. Conversely, evacuation may allow time for negotiation and become a "side issue" under crisis conditions.

5. American Risk-Taking. Some CD opponents point out that a false sense of security provided by high levels of CD could lead to American adventurism, and resulting disaster. Opponents counter that CD is inefficacious and therefore cannot provide a real, let alone false, sense of security. The role civil defense could, or should, play is clearly beset with controversy as well as a plethora of uncertainties.

"In assessing the debate over CD vis-a-vis the strategic balance, it is essential to keep in mind that judgements cannot be made with certainty or even at a high level of confidence, as to the factors or perceptions that could enter into the calculus of decision-makers during a future crisis, and might tend either to deter or encourage escalation."<sup>83</sup>

#### Civil Defense: The Soviet Example (1.8-1)

According to the Central Intelligence Agency's (CIA) 1978 report, the goals of Soviet civil defense are to: "protect the leadership, essential workers, and others in priority order; to protect productivity; and to sustain people and prepare for economic recovery following an attack." The prime motivations for developing the U.S.S.R. civil defense program stem from "the traditional Soviet emphasis on homeland defense, (the desire) to convince potential adversaries they cannot defeat the Soviet Union, (the desire) to increase Soviet strength should war occur, (the

desire) to help maintain the logistics base for continuing a war effort following the nuclear attack, (the desire) to save people and resources, and (the desire) to promote postattack recovery."<sup>84</sup>

According to a Civil Defense Preparedness Agency study, the Soviet CD capability is characterized by the following factors:

1. Soviet CD is a nationwide program under military control. The CD organization consists of over 100,000 full-time personnel at all levels of the Soviet government and economy.
2. The Soviets have made a sustained effort to provide blast shelters for their leadership and essential personnel. Blast protection is available for virtually all of the leadership at all levels, and for at least ten to twenty percent of the urban population including essential workers.
3. Evacuation during a crisis would be the predominant means for reducing urban casualties. It would take a week or more to evacuate urban areas and to develop fallout shelters in rural areas which would then provide a high level of protection for the evacuees.
4. Performance of Soviet CD would depend primarily on the time available for evacuation and other preparations:
  - a. With several hours to make final preparations, a large percentage of leaders and communications facilities would probably survive.
  - b. A large percent (75 to 90 percent) of the essential work force in blast shelters would survive an attack designed to maximize damage to economic facilities.
  - c. Given a week or more to complete urban evacuation, nuclear effects and fallout could be reduced to the low tens of millions, about half of which would be fatalities. (This suggests fatalities of five, ten, or perhaps fifteen million, or around five percent of the Soviet population.)
5. Soviet measures to protect the economy could not prevent massive industrial damage. Some improvements are expected in ability to protect the economy, but a substantial decrease in vulnerability is unlikely.
6. The Soviets believe their present civil defenses would improve their ability to conduct military operations and would enhance the U.S.S.R.'s chances for survival following a nuclear exchange. The U.S. intelligence community does not believe that the Soviets' present civil defenses would embolden them deliberately to expose the U.S.S.R. to a higher risk of nuclear attack.<sup>85</sup>

## Civil Defense: The U.S. Example (1.8-2)

During the pre-detente period of the 1950s, U.S. civil defense policy was characterized by evacuation plans based on tactical warning and bomber flight times. These plans were abandoned, however, as the fear of nuclear warfare diminished. "The United States had an overwhelming strategic superiority over the Soviet Union so that any attack could be met with devastating retaliation."<sup>86</sup>

After the Cuban Missile Crisis of 1962, President Kennedy vigorously promoted an expanded CD program under the rationale of "insurance" in an uncertain world in case of an enemy miscalculation. (It had been discovered during the Cuban Crisis that Miami and other cities in Florida could not have been evacuated in any practical manner since no appropriate plans had been made.)

The heightened concern with civil defense enabled Kennedy to push the civil defense budget to its all-time high in 1962 when Congress appropriated \$207.6 million for the new office of Civil Defense plans for group fallout shelters. By the late 1960s, however, annual appropriations for all Civil defense operations had dropped to less than half of the 1962 appropriations.

During the 1960s, Soviet military strength grew. The race between the U.S. and U.S.S.R. to develop nuclear arms intensified, resulting in the first Strategic Arms Limitations Talks (SALT) in 1969. A full-scale nuclear war seemed unimaginable during an era of mutually assured destruction and detente, and concern for civil defense dwindled.

With the submission of a report to Congress in 1976, however, Defense Secretary Donald Rumsfeld warned that the growing asymmetry of Soviet and American civil defense preparedness was weakening the credibility of U.S. deterrence.<sup>87</sup> Thus, from 1976 to 1978, the Carter Administration conducted several studies on the U.S. civil defense preparedness programs.

The first was an intelligence community assessment of Soviet CD. The second was a Department of Defense study on the feasibility, costs, and performance of alternative U.S. civil defense programs. The third was an interagency study stemming from the other two studies. The third study also considered the strategic elements of civil defense. These studies were the most exhaustive examinations of civil defense that had ever been done and led to Presidential Decision (PD) 41.

PD 41 of September 1978 directed a new CD policy along the following lines:

1. CD should enhance survivability and improve the basis for recovery from the reduce vulnerability to a Soviet attack.
2. The program should enhance deterrence and reduce Soviet ability to coerce the U.S.
3. The new CD policy should not change our policy relying on strategic forces as the chief factor in maintaining deterrence.

4. The Crisis Relocation Planning program was to be able to function during times of international crisis and also during peacetime emergency.<sup>88</sup>

As a policy statement, PD 41 did not include any program details nor budget requirements. It simply listed civil defense options and suggested associated requirements. One option was crisis relocation planning (CRP).

The federal implementing agency for CD programs, the Federal Emergency Management Agency (FEMA), has determined that between blast shelter systems and crisis relocation planning, the latter is "the only moderate-cost approach which has high potential for survival."<sup>89</sup>

While a blast shelter system would provide residents with more immediate protection, FEMA estimates that developing such a system would cost over \$60 billion in an age of "fiscal restraint."<sup>90</sup> While evacuation requires more lead time and better organization, the Agency states that relocation can be effective "given the requisite planning and development of supporting systems and capabilities and given about a week for moving and protecting the bulk of our population at risk."<sup>91\*</sup>

Despite the emphasis on CRP, it should be noted that in-place protection of the population is maintained as a fall-back plan in case "time or circumstances don't permit crisis relocation."<sup>93</sup> Perhaps one third of the United States' population has available shelters in nearby large buildings. Others have a basement available that would be a suitable shelter. The present plan for in-place protection rests on using buildings and materials already in place rather than on constructing new blast shelters.<sup>94</sup> Essentially, the plan provides for fallout protection since very few blast-resistant structures exist.

#### Crisis Relocation Planning: Current Status (1.8-3)

The current emphasis of the U.S. civil defense program continues to remain on Crisis Relocation Planning. It "is an effort to develop plans and related systems and capabilities to relocate people from large U.S. cities and other possible risk areas,

\*The best-financed civil defense system in the Western World is Switzerland's system, which by 1980 had provided protected fallout shelter spaces for over six million people, 90 percent of the Swiss population. According to the Swiss Office of Civil Defense, mass evacuation approaches were excluded from federal planning at an early point. Reasons given include: "Transportation of the people into the receiving areas and an adequate supply could not be guaranteed under war operations. Furthermore, such evacuation activities could hinder important general defense actions. The uncertainty regarding time and duration of such evacuations would render the operation especially difficult. Consequently, large scale transfers of people in a modern war in this country are ineffective and even dangerous and must be avoided. This is feasible on condition that each inhabitant is provided with a shelter place at or near his domicile."<sup>92</sup>



during a crisis that could escalate to a nuclear attack on this country."<sup>95</sup> Current planning is being done by about 140 professional planners. Most of them are hired under contract between the states and the federal government. The latter provides all of the funding. Initial plans are to be completed in the late 1980s or shortly thereafter. Plans must be developed for 400 risk areas and over 1,500 host areas that would receive evacuees if the plans were implemented.<sup>96</sup>

The basic plans assume that two-thirds of the population live in high risk areas in case of a nuclear war due to closeness to key military and economic targets. Most of the population in risk areas is to be moved to host areas far enough away to be safe from nuclear blast.<sup>97</sup> In order to keep the economy going, the most essential activities are to be kept in operation in the risk areas throughout the relocation period. Services such as fire and police protection for evacuated cities, maintenance of food production and distribution, and keeping refineries and certain other critical industries operational will be essential.

The plans will provide for the "key workers" to move with their families to relatively nearby host areas and to commute into the risk areas on a shift basis. For example, the "key workers" in an oil refinery would not be the entire work force, but only enough to keep the facility in operation.

In the host areas, all economic activities would be kept in full operation, insofar as possible.<sup>98</sup> The plans call for most of the evacuated population to be conducted in privately owned vehicles although some of the evacuated population will move by other means. A public opinion sample done by the Defense Civil Preparedness Agency (DCPA) in October and November of 1978 revealed that 88 percent of the people questioned had a vehicle of their own to use. Two-thirds of those lacking a car were certain neighbors, friends, and relatives would give them a ride.<sup>99</sup> People without their own transportation will be bused to host areas. In densely populated areas, rail or air may also be used for transportation.<sup>100</sup> However, most families will be expected to move themselves to the host areas.

Initial reception of the evacuees is to be much like that for other disaster victims such as those fleeing floods or hurricanes. The federal government is conducting "Host Area Shelter Surveys" to identify buildings such as schools and churches which are suitable to use as temporary shelters for evacuees.<sup>101</sup> As yet, no plans exist for involuntary billeting of evacuees in private homes. However, many people have indicated a willingness to accept evacuees in their homes.<sup>102</sup>

Host area residents and evacuees are to improve existing structures for protection from fallout. Relocation plans are to be provided for mobilization of all available earth-moving equipment. However, self-preservation is the great motivating factor in making the shelter building plan work. The average American family is expected to do a lot of its own digging.

Individual initiative and the private sector of the economy are to feed the population. People will be asked to bring several day's worth of non-perishable food

on their own. Several day's more supply of food is expected to be in the stores in the host areas. Food distributors are expected to change delivery patterns to stock host areas.<sup>103</sup>

It should be noted that some areas of the country present special planning problems. In the Northeast, nearly four-fifths of the the people live in possible risk areas, and the percentage is even higher in California. The federal government has conducted special feasibility studies of crisis relocation for the Northeast and California. These studies suggest that crisis relocation would be feasible, but that traffic control, movement, and problems such as food distribution and shelter construction would require a great deal of detailed work by planning professionals.<sup>104</sup>

Present CRP plans rest on three assumptions. One is that a large part of the population will cooperate with evacuation orders and instructions. Another is that key personnel will act in a relatively stable and supportive manner. The last assumption is that sufficient warning time will be available to implement CRP.

Several conditions need to be met in order for the federal plans to be successful. The first is that state and local governments must cooperate before the emergency in preparing the implementation of their planned respective roles. The second is that state and local governments have adequate plans for the emergency. The third is that private business will be responsible for keeping the economy running during the emergency. Any one of these factors could affect CRP's effectiveness.

Crisis Relocation Planning is predicated on the assumption that the affected population will cooperate with evacuation orders and instructions. Based on wartime experience with CD in Britain and Germany and peacetime experience with hurricanes in the United States, 80 percent of the population in risk areas is expected to cooperate with relocation orders. Ten, twenty, or possibly thirty percent are expected to not cooperate. Some people may evacuate on their own initiative. Looting and other forms of antisocial behavior are not expected to be major problems due to the assumption that "in a threat situation, human beings realize almost instinctively that cooperative behavior is much more to their benefit than conflict or struggle."<sup>105</sup> In support of this contention, DCPA cites the case of Hurricane Carla in 1961. Over one-half million people were evacuated from the Gulf Coast with no fatalities or major accidents. Although the New York City blackout was accompanied by considerable looting, DCPA argues that many people helped each other and that the perceived danger was not great enough to make all act in a cooperative manner as would threat of nuclear attack.<sup>106</sup>

For effective enactment of the plans, key personnel will need to accept risks and harsh conditions. These personnel include policemen, firemen, certain workers in essential industries, and deliveries of food and essential provisions. Their cooperation is critical to the success of the evacuation plans.<sup>107</sup>

Sufficient warning time will be necessary to allow evacuation plans to be implemented. Most of the population in high risk areas could be evacuated in three days. New York City, Los Angeles, and San Francisco could take four days to complete evacuation plans.<sup>108</sup>

In order for the federal plans to work, state and local governments must cooperate to carry out the role Washington expects of them. DCPA admits that if a local government is reluctant or rejects the plan, the CD program's implementation must wait until local authorities change their minds.<sup>109</sup>

State plans are expected to provide for supplying food and other essentials to the population and for supporting local government operations (for example, state police are to assist local traffic control efforts). Local governments of host areas are to provide traffic control and parking, temporary lodging and food, and fallout shelters. Plans by local governments within risk areas are to provide for the initial relocation move, commuting of evacuated essential workers to their jobs in risk areas, and blast protection for those still in those areas. Maps and evacuation instructions are to be prepared for risk area residents and ready for publication in local newspapers in case evacuation becomes necessary.

The food redistribution plan depends almost entirely on present means of commercial distribution. The costs for austere emergency rations and other supplies for evacuees (for prestocking) at today's prices would be approximately a half billion dollars. Thus, it is considered more cost effective to rely on adjusting the existing food distribution system.<sup>110</sup>

In 1978, the Department of Defense allocated \$230 million a year for FY's 1980-84 to fund a CD program adequate to insure a two-thirds survival rate with one week notice of an attack.<sup>111</sup> The current projected CD budget is \$100-110 million a year. Funds are not available to rehearse evacuation plans "or for improving current marginal capabilities in such areas as Direction and Control, Warning, Communications, Radiological Defense, Emergency Public Information, and Training."<sup>112</sup> "Paper plans only" insure no more than a 50 percent survival rate. DCPA has indicated that a 50 percent survival rate does not affect the strategic balance and does not enhance U.S. ability to resist coercion.<sup>113</sup>

#### War Emergency Plan: The California Example (1.8-4)

The basis of California's CD planning is the War Emergency Plan, which was published in 1970 and is currently being revised to cover crisis relocation. It is based on the assumption that adequate planning and warning can limit civilian casualties.<sup>114</sup> The plan elaborates a State War Emergency Organization and assigns tasks to each element. Provisions are made for a Direction and Control Group, Staff Sections, Emergency Resources Management, and Emergency Services.<sup>115</sup> Also provided for are sub-state level regional organizations for wartime. State Mutual Aid Regions consist of several counties. Within each Region are (County) Operational Area Organizations and within each of these are City and County (i.e. unincorporated areas) Organizations. These organizations are all given specific responsibilities.<sup>116</sup> Additionally, manpower from each department of the State government has been assigned an emergency service or system. For example, the California Highway Patrol is assigned to the Law Enforcement Service. The Military Department is assigned to both the Welfare and Law Enforcement Services.<sup>117</sup>

The provisions of California's War Emergency Plan are being expanded under a Nuclear Civil Protection Planning contract with the Federal Emergency Management Agency (FEMA). In addition to the 1970 version plan with provisions for Fire and Rescue, Law Enforcement, Medical and Health, and Reception and Care/Emergency Welfare, the 1980 plan increases these emergency services to include Movement Operations and Shelter Development/Engineering plans.<sup>118</sup>

Parts of the plan delineate specific time periods such as Preparedness Period (Increased Readiness and Crisis Relocation)<sup>119</sup> and Attack and Early Post-Attack Periods.<sup>120</sup> Another part of the plan includes System and Support Annexes. These annexes include Direction and Control, Movement Operations, Reception and Care, Law and Order, Fire and Rescue, Medical and Health, Shelter Development, Economic Considerations and Controls, and Resources Management. The Resources Management Annex has completed appendices entitled Construction/Engineering, Health, Housing, Industrial Production, Manpower, Supply/Procurement, Telecommunications, and Utilities.<sup>121</sup>

As of May 1980, parts of the California plan remain incomplete. These are the Food, Fuel, and Transportation Appendices. Their impact on other parts of the plan is apparent when it is remembered that the purpose of the Resources Management Annex is to "(o)versee...distribution and/or redistribution of food and other essential supplies." and to "(a)rrange for transportation to meet essential needs."<sup>122</sup> The importance of the missing appendices is underscored when it is recalled that the shortage of materials for fallout shelters in host areas is assumed to be solvable by diversion of materials from other areas.<sup>123</sup> The missing appendix for food resources management is especially critical since the federal government expects this responsibility to be assumed by the state governments.

The Riverside County Operational Area General Plan for Nuclear Civil Protection basically follows the guidelines of the California State NCP. Specific plans have been elaborated for various kinds of operations (i.e. Increased Readiness, Crisis Relocation, and Attack Operations). Systems or functional plans are organized as annexes (i.e. Direction and Control, Law and Order, Medical and Health, Reception and Care, and Resources and Support).<sup>124</sup>

Essential to the workings of the plan are several supporting documents. The Riverside County Operational Data Manual "provides essential information regarding the resources available within the county, as well as those that would have to be provided by outside sources, all of which would be required to effectively conduct emergency operations."<sup>125</sup> There are several special purpose plans that are published separately from the General Plan as support documents (i.e. Crisis Relocation, Crisis Relocation Movement Control, Emergency Public Information, and Fallout Shelter Development).<sup>126</sup>

The smallest unit of analysis for CD planning in Riverside County is the local planning zone. Some zones, for example, Zone 11 - City of Riverside, have plans for evacuation.<sup>127</sup> Others, for example, Zone 66 - City of Indio, have plans to serve

as host areas.<sup>128</sup> The degree of risk of nuclear attack to the local area has been the deciding factor in determining whether or not a city is to be evacuated or to serve as a host area.

An examination of state, county, and city plans reveals certain problems in their preparation. These include:

1. There is a lack of planning in the key areas of food, fuel, and transportation.
2. Preliminary studies indicate certain communications weaknesses.
3. Crisis Relocation Planning must confront problems inherent in dealing with unknown quantities.
4. Planning is based on the assumption that enough time will be available during a crisis to alleviate deficiencies in preparation.

The omission in state planning for food, fuel, and transportation seriously affect Riverside County's CD preparations. County emergency planners expect local government emergency planners to stockpile food in shelters for immediate needs; the state is expected to redirect food supplies commensurate with local needs.<sup>129</sup> The county's Movement Control Plan calls for vehicles to be refueled by gas truck. Although the refueling point is identified in the plan, it is not clear who is responsible for providing the gas trucks. According to the state officials, California's War Emergency Plan is in its third year of development and it is hoped that the key problem areas noted above will be addressed by the end of Fiscal Year 1981.

It is estimated that Riverside County will need shelters for 1,197,000 people who will be relocated from Los Angeles and San Diego Counties. Riverside County lacks sufficient resources for shelter construction and must get them from evacuated areas.<sup>130</sup> These requirements for resources cannot be met until state plans are completed.

Communications problems could adversely affect execution of the plans for orderly evacuation, law enforcement, and traffic control. Many of the county police departments' radio sets lack frequencies compatible with other departments. Current plans call for using police units from evacuated areas in other parts of the county.<sup>132</sup> Until the problem of compatible radio frequencies is solved, police operations in support of evacuation will be hindered.

The author of the county's Crisis Relocation Movement Plan admits that planning for evacuation is an uncertain process. A planner cannot be certain of the number of people who will respond to orders to evacuate in a crisis, the number of vehicles they will use, the number of people who will evacuate "spontaneously" (i.e. without government orders), and the exact destination evacuees will choose.<sup>133</sup>

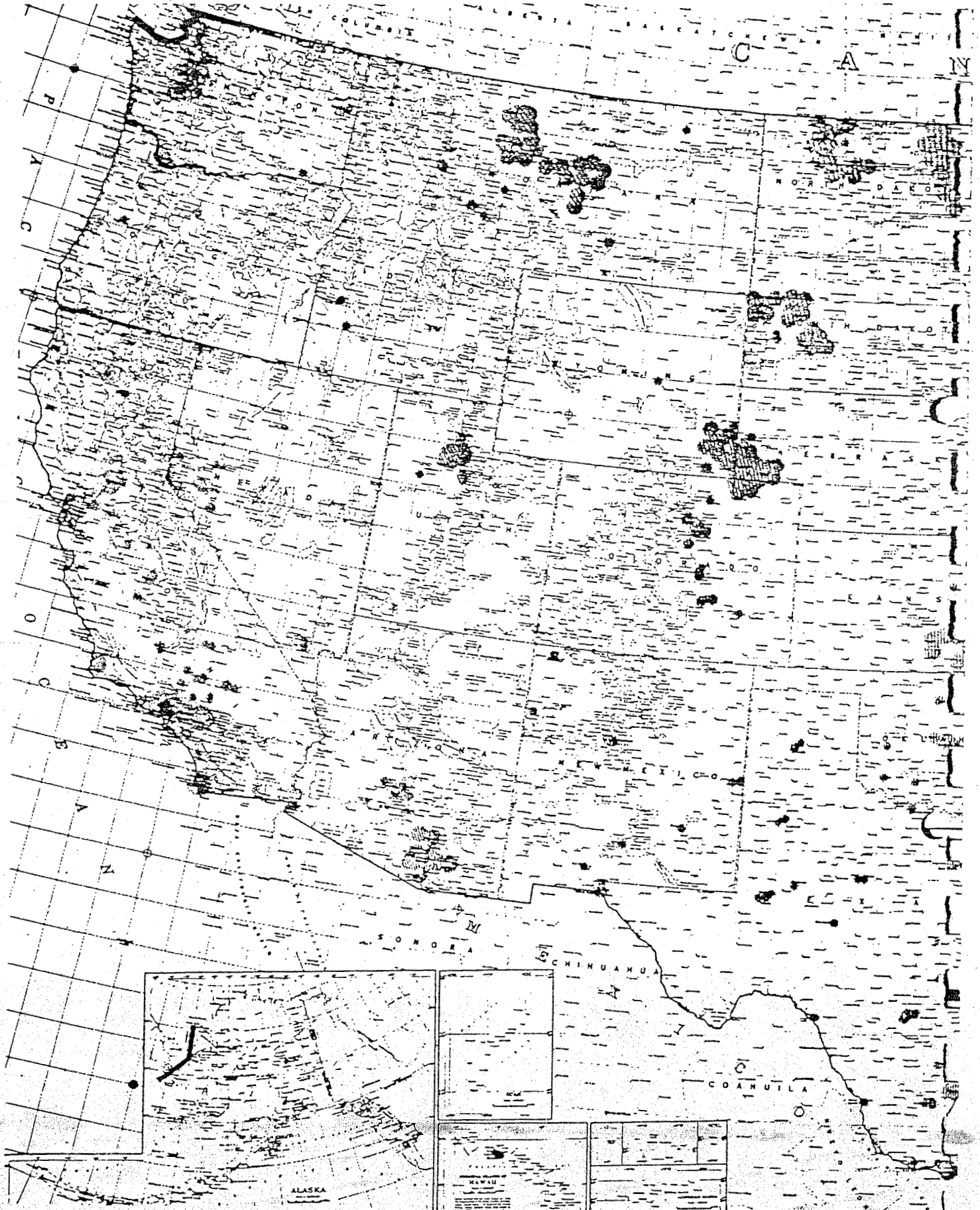


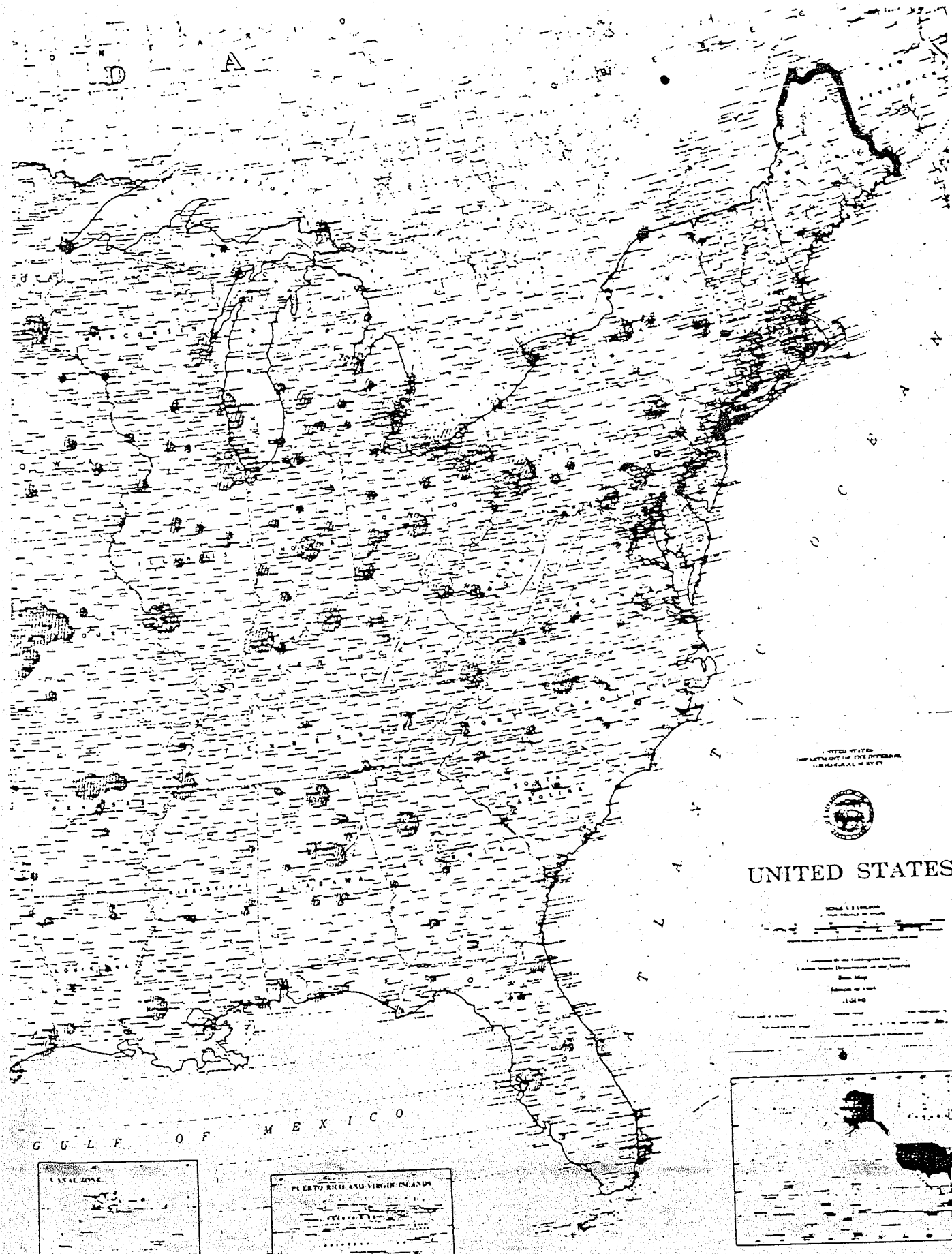
Some critical tasks may not be accomplished until it is too late. Many actions necessary to carry out CD plans are not scheduled to be accomplished until increased readiness is announced. This includes preparations for the stockpiling of shelters<sup>134</sup> and preparation of signs needed to control crisis traffic movement.<sup>135</sup> None of the mentioned local plans have any specific time for review and update before announcement of increased readiness. U.S. "high-risk" areas, e.g., those likely to be bombed in nuclear war, are shown in Figure 1.8-1.



Figure 1.8-1136

U.S. HIGH RISK AREAS  
(Potential Nuclear Targets)



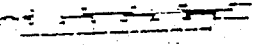


UNITED STATES  
DEPARTMENT OF THE INTERIOR  
GEOLOGICAL SURVEY



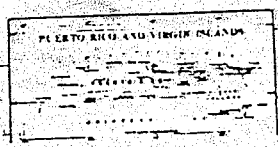
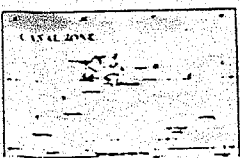
# UNITED STATES

SCALE 1:100,000



UNITED STATES  
DEPARTMENT OF THE INTERIOR  
GEOLOGICAL SURVEY

GULF OF MEXICO



## Conclusions (1.9)

The emergency issue of vulnerability of energy systems is recognized by the U.S. Office of Technology Assessment of the former Defense Civil Preparedness Agency (now the Federal Emergency Management Agency). The "industrial attack" option in a U.S. -Soviet Union nuclear exchange is assumed to be that petroleum facilities will be targeted.\*

At this point in U.S. history, understanding the problem of energy vulnerability is at a general state. Most studies and official reports consider the primary effects of nuclear targeting on some facilities, but little work has addressed sub-system components and other scenarios for widespread damage for the U.S. economy through massive disruptions in conventional supplies of electricity and fuels. In this first section, we have outlined historic lessons in energy targeting, provided an overview of centralized systems, focused on vulnerability of these systems to sabotage and disruption, and discussed civil defense planning for contingencies.

In the following section, a more detailed survey and discussion of centralized U.S. energy systems is given, including future courses for electricity and synthetic fuels development.

---

\*To comply with the mandate of the recently enacted Energy Security Act, it has been estimated that approximately forty synthetic fuel plants, each with a capacity of 50,000 barrels per day, will be required. Although these plants may not be considered prime strategic targets in an all out nuclear exchange, they are very attractive secondary targets. Also due to their highly centralized nature, they may well be prime targets for terrorist attacks.

In World War II, the Allies destroyed over 90 percent of the German synthetic fuel industry. To destroy 90 percent of the newly proposed U.S. synthetic fuel industry (representing an initial investment of over \$80 billion) would require an extremely minimal fraction of the Soviet targeting capability, much less than one percent of the Soviet nuclear arsenal.

SECTION I  
ENERGY AND VULNERABILITY

FOOTNOTES

1. Nye, Joseph, "Energy and Security: Report of a Harvard Workshop," May 26, 1980, Draft, p. 11.
2. Glassey, Roger and Paul Craig, "Vulnerability of Renewable Energy Systems: in Distributed Energy Systems in California's Future, U.S. Government Printing Office, Washington, D.C., May, 1978, p. 330.
3. Fesharaki, Fereidun, "Global Petroleum Supplies in the 1980's: Prospects and Problems," February, 1980, p. 2.
4. Ibid., p. 1.
5. Nye, op. cit., p. 3.
6. Fesharaki, op. cit., p. 10.
7. Nye, op.cit., p. 5.
8. Energy Information Administration (EIA), United States Department of Energy (DOE), 1980.
9. Schurr, Sam M., ed., Energy in America's Future: The Choices Before Us, Resources for the Future, Johns Hopkins University Press, 1979, p. 233.
10. Ibid., p. 236.
11. International Energy Statistical Review, National Foreign Assessment Center, July 29, 1980, (Courtesy EIA).
12. Schurr, op, cit., p. 390.
13. Stobaugh, Robert and Daniel Yergin, eds., Energy Futures: Report of the Energy Project at the Harvard Business School, New York, Ballantine Books, November, 1980, p. 154.
14. "Russia's Sudden Reach for Raw Materials," Fortune, July 28, 1980, p. 44.
15. "Apocalypse Soon...In Minerals," Defense Weeks, September 22, 1980, p. 9.
16. Table 1.2-1, "U.S. Reliance on Strategic Materials," Source: Fink, Donald E., "Availability of Strategic Materials," Aviation Week and Space Technology, May 5, 1980, p. 44, (Modified by Energy and Defense Project).

FOOTNOTES (Continued)

17. Table 1.2-2, "Estimated Quantities of Materials Used in Reactor Core Replaceable Components of Water-cooled Nuclear Power Plants," Source: Spangler, M.B., United States Experience in Environmental Cost-Benefit Analysis for Nuclear Power Plants with Implications for Developing Countries, NUREG-0701, Office of Nuclear Reactor Regulation, August, 1980, p. 73.
18. Fink, op. cit., p. 44.
19. "Apocalypse Soon...In Minerals," op. cit.
20. Ibid.
21. Ibid.
22. Ibid.
23. Stephens, M. M., "Vulnerability of Total Petroleum Systems," U.S. Department of Interior, Office of Oil and Gas, May, 1973, p. 14.
24. "Pipeline Economics," Oil and Gas Journal, August 13, 1979, p. 69, (Courtesy EIA).
25. Ibid., p. 16.
26. "Petroleum Refineries in the United States and U.S. Territories," DOE/EIA Energy Data Reports, January 1, 1979, p. 3.
27. Stephens, M.M., "Minimizing Damage to Refineries from Nuclear Attack, Natural and Other Disasters," U.S. Department of Interior, Office of Oil and Gas, February, 1970, p. 40.
28. Stephens, M.M., et. al., "Vulnerability of Natural Gas Systems," U.S. Department of Interior, Office of Oil and Gas, March, 1974, p. 3.
29. "Natural Gas Production and Consumption: 1978," DOE/EIA Energy Data Reports, p. 3-24.
30. Gas Facts, American Gas Association (AGA), Arlington, Virginia, p. 55, Table 44, (Courtesy EIA).
31. Katz, A., "Economic and Social Consequences of Nuclear Attacks on the United States," U.S. Senate, Committee on Banking, Housing, and Urban Affairs, 96th Congress, 1st Session, March, 1979, p. 82.
32. "Power Production, Fuel Consumption, and Installed Capacity Data for 1979," Energy Data Reports, (Courtesy EIA).

FOOTNOTES (Continued)

33. Ramberg, Bennett, "Destruction of Nuclear Energy Facilities in War: A Proposal for Legal Restraint," World Order Studies Program, Princeton University, 1978, p. 4.
34. Economic and Social Consequences of Nuclear Attacks on the United States, Committee Print, Committee on Banking, Housing, and Urban Affairs, 96th Congress, 1st Session, 1979, p. 19.
35. "Domestic Terrorism," Emergency Preparedness Project Center for Policy Research, Defense Civil Preparedness Agency (DCPA), May, 1979, p. 1.
36. Ibid., p. 2.
37. Kupperman, Robert and Darrell Trent, Terrorism: Threat, Reality, Response, Hoover Institution Press, Stanford Ca., May, 1979, p. 106.
38. Stephens, M. M., "The Oil and Natural Gas Industries: A Potential Target of Terrorists," in Kupperman, op. cit., pp. 206-208.
39. Ibid., pp. 206-208.
40. Ibid., pp. 206-208.
41. Table 1.4-1, "Incidents of Energy-Related Terrorism," Source: Energy and Defense Project.
42. Smith, Phillip, "Findings of National Security Council Ad Hoc Committee on Assessment of Consequences and Preparations for a Major California Earthquake," Memorandum to Governor E.G. Brown, Jr., The White House, Washington, D.C., August 29, 1980, pp. 1-2.
43. Ibid., p. 3.
44. Ibid., p. 7.
45. Ibid., Annex II, p. 4.
46. U.S. Strategic Bombing Survey. "The Effects of Strategic Bombing on the German War Economy," U.S. GPO, January, 1947, p. 114.
47. Ibid., p. 115.
48. Ibid., p. 114.
49. Ibid., pp. 114-115.
50. Ibid., p. 115.



FOOTNOTES (Continued)

51. Ibid., pp. 49-50.
52. Ibid., pp. 47-48.
53. Ibid., p. 51.
54. Figure 1.6-1, "Loss of German Power Plant Capacity Due to Allied Action," Source: U.S. Strategic Bombing Survey, "German Electric Utilities Industry Report," U.S. GPO, January, 1947, pp. 46-50.
55. Ibid., p. 21.
56. Figure 1.6-2, "Air Raid Damage to German Synthetic Fuel Production," Source: Emergency Fuels Composition and Impact, Southwest Research Institute Houston, Texas, December, 1978, pp. 20-21.
57. U.S. Strategic Bombing Survey (Pacific), "The Electric Power Industry of Japan," Electric Power Division, December 3, 1945, p. 5.
58. Ibid., p. 31.
59. Ibid., p. 14.
60. Table 1.6-1, "Total Air Raid Damage to Generating Facilities of the Japanese Utility System," Source: U.S. Strategic Bombing Survey (Pacific), op. cit., p. 79.
61. Figure 1.6-3, "Major Sources of Japanese Electricity Generation," Source: Energy and Defense Project.
62. Figure 1.6-4, "Percent Air Raid Damage to Japanese Small Hydro and Steam Electricity Production," Source: Ibid.
63. U.S. Strategic Bombing Survey (Pacific), op. cit., p. 25.
64. Ibid., p. 31.
65. Ramberg, Bennett, Destruction of Nuclear Energy Facilities in War: The Problem and Implications, Heath and Company, Lexington, Ma., 1980, p. 15.
66. Calder, Nigel, Nuclear Nightmares, An Investigation into Possible Wars, Viking Press, N.Y., 1978, p. 2.
67. Ibid., p. 15.
68. Figure 1.6-5, "The Extent of the Fighting," Source: Energy and Defense Project.

FOOTNOTES (Continued)

69. Marshall, Eliot, "Iraqi Nuclear Program Halted by Bombing," Science, October, 1980, p. 508.
70. Ibid., p. 507.
71. Table 1.7-1, "U.S. and Soviet Strategic Nuclear Forces (1980 Totals)," Source: Stockholm Institute of Peace Research.
72. "Nato and the Warsaw Pact," The Economist, August 9, 1980, p. 36.
73. Figure 1.7-1, "Detroit 1 MT Air Burst," Source: Federal Office of Technology Assessment (OTA), The Effects of Nuclear War, OTA-NS-89, Washington, D.C., May, 1979, p. 29.
74. Table 1.7-2, "Blast Effects of a 1 MT Explosion 8,000 Feet Above the Earth's Surface," Source: Ibid, p. 18.
75. Ibid., p. 32.
76. Figure 1.7-2, "'Footprint' of Hypothetical Nuclear Attack on Detroit," Source: Ibid., p. 24.
77. OTA, op. cit., p. 64.
78. Ibid., pp. 72-73.
79. Table 1.7-3, "Summary of Population and Target Damage Resulting from Different Classes of Nuclear Attacks," Source: Ibid., p. 10.
80. Civil Defense for the 1980's -- Current Issues, DCPA, July 13, 1979, p. 10.
81. Ibid., p. 10.
82. Ibid., p. 40.
83. Ibid., p. 40.
84. Ibid., pp. 18-19.
85. Ibid., pp. 12-13.
86. Lanouette, William, "The Best Civil Defense May Be the Best Offense," National Journal, September 9, 1978, p. 1421.
87. Ibid., p. 1421.
88. Civil Defense for the 1980's -- Current Issues, op. cit., p. 25.
89. Ibid., p. 15.

FOOTNOTES (Continued)

90. Ibid., p. 15.
91. Ibid., p. 17.
92. Aeberhard, Robert, The Swiss Civil Defense, Federal Office of Civil Defense, Berne, Switzerland, 1980, p. 17.
93. DCPA, "Questions and Answers on Crisis Relocation Planning," Information Bulletin No. 305, GPO, Washington, D.C., April 20, 1979, p. 28.
94. Ibid., p. 6.
95. Ibid., p. 1.
96. Ibid., p. 26.
97. Ibid., p. 1.
98. Ibid., p. 13.
99. Ibid., p. 23.
100. Ibid., pp. 9-10.
101. Ibid., pp. 23-25.
102. Ibid., pp. 11-13.
103. Ibid., p. 10.
104. Ibid., pp. 17-18.
105. Ibid., pp. 7-8.
106. Ibid., pp. 14-15.
107. Ibid., p. 13.
108. Ibid., p. 5.
109. Ibid., p. 17.
110. Ibid., p. 10.
111. Ibid., pp. 2-3.
112. Ibid., pp. 27-28.
113. Ibid., p. 29.

FOOTNOTES (Continued)

114. California Office of Emergency Services (OES), State of California Emergency Plan, Part 4, War Emergency Plan, State of California, 1970, pp. 1-2.
115. Ibid., pp. 13-27.
116. Ibid., pp. 18-29.
117. Ibid., pp. 14-16.
118. Ibid., pp. 10-12.
119. OES, War (Nuclear Civil Protection) Plan, Section 2, Preparedness (Increased Readiness and Crisis Relocation) Period, Draft, State of California, March 7, 1980.
120. Ibid., Section 3, Attack and Early Post-Attack Periods, Draft, State of California, July 13, 1979.
121. Ibid., Section 4, Annexes 1-9.
122. Ibid., Annex 9, p. 1.
123. Ibid., Annex 7, pp. 5-6.
124. Center for Planning and Research, Incorporated, Riverside County Operational Area General Plan for Nuclear Civil Protection, Draft, State of California, December 14, 1979, p. ii.
125. Ibid., pp. i-ii.
126. Ibid., p. ii.
127. Center for Planning and Research, Incorporated, Nuclear Civil Protection Plan of Riverside and Vicinity, Draft, State of California, September 30, 1979, p. 3.
128. Center for Planning and Research, Incorporated, Nuclear Civil Protection Plan City of Indio and Vicinity, Draft, State of California, September 3, 1979, p. 3.
129. Riverside County General Plan, op. cit., III-9.
130. Center for Planning and Research, Incorporated, Riverside County Operational Area Nuclear Civil Protection Fallout Shelter Development Plan, Draft, State of California, December 13, 1979, p. 1.
131. Hubenette, Robert W., Riverside County Crisis Relocation Movement Control Plan, Preliminary Draft, State of California, September 30, 1979, p. 15.

FOOTNOTES (Continued)

132. Nuclear Civil Protection Plan City of Riverside and Vicinity, Draft. op. cit., p. 7.
133. Hubenette, op. cit., p. 3.
134. Nuclear Civil Protection Plan City of Indio and Vicinity, Draft, F-5, and Nuclear Civil Protection Plan City of Riverside and Vicinity, F-5.
135. Hubenette, op. cit., p. 10.
136. Figure 1.8-1, "U.S. High Risk Areas (Potential Nuclear Targets)," Source: Prepared for DCPA by the U.S. Geological Survey, 1965.

SECTION 2

ENERGY: EXISTING SYSTEMS AND TRENDS



## ENERGY: EXISTING SYSTEMS AND TRENDS (2.0)

### Introduction and Overview (2.1)

The energy system in the United States today is highly centralized. Production of electricity for consumer use depends on an increasingly centralized system of large generating plants, which in turn depend on other centralized systems of fuel production, transportation, refining, and storage. Fuel deliveries to the consumer rely on similarly centralized systems of production, transportation, and storage.

The terms "centralized" and "decentralized" are not readily quantifiable terms, nor are the related concepts of "large-scale" and "small-scale." Generally, centralized power is the dependence of an energy system on a relatively small number of large components. This definition can be applied accurately to each of the various subsystems such as transportation which make up the U.S. energy system. As electrical generating plant sizes and their service areas increase, a centralized dependency emerges.<sup>1</sup>

A second important characteristic of our energy system is its energy-intensity. In every stage of its operation, today's energy system requires substantial energy to maintain itself. For example, four percent of each barrel of oil produced is consumed in the refinery operation.<sup>2</sup>

Converting energy from one form into another involves not only irreversible entropic losses but often is accompanied by rejection of large amounts of waste heat to either atmospheric or water coolant systems. For example, converting oil into electricity by first burning it in a boiler to heat water to make steam to rotate a turbine usually results in a loss of about two-thirds of the initial energy introduced into the system. Most conventional electric utility power plants require about 10,000 Btus of fuel energy to produce one kilowatt-hour of electricity, whereas if the process were 100 percent efficient, it would require only 3,413 Btus.

These limitations on thermodynamic efficiency are especially significant because approximately 30 percent of all basic energy inputs in the U.S. are used for the generation of electricity. The equivalent of about 1.6 million barrels of oil per day are used for electricity generation. 1.1 million are irretrievably lost due to thermodynamic inefficiencies, energy conversion processes and waste heat rejection. This loss is an amount equal to about seventeen percent of all oil imports to this country.<sup>3</sup>

U.S. reliance on centralized energy systems has evolved over the last one hundred years. Aside from human and animal labor, wood was the primary source of energy in America until after the Civil War. From 1850 to 1865, when coal began to replace overcut forest, wood produced between 80 and 90 percent of the nation's energy requirements.<sup>4</sup>

The introduction of coal into the American economy in the 19th Century was not the first time this energy source had been used on the continent. The Hopi Indian tribe mined coal in what is now Arizona in 1000 A.D. By the time the Spaniards reached the area, more than 100,000 tons (90.7 million kg) had been mined. The European pioneers had an abundance of wood available to them and coal was unnecessary until they had decimated the forests in the mid-19th Century. Between 1850 and 1861, as the new iron and steel industries grew and coal replaced wood for boiler fuel, the consumption of coal tripled. By 1885, coal surpassed wood in overall fuel use in the U.S. Coal supplied 65 percent of U.S. energy needs in 1895, and remained the dominant fuel well into the 20th Century.<sup>5</sup>

Liquid fuels such as kerosene and petroleum were an important addition to the U.S. energy supply. Both were developed as cheap substitutes for whale oil, a common lamp fuel grown increasingly scarce. Coal oil, or kerosene, was a liquid fuel made from coal by processes invented in England. By the 1850s there were 50 to 60 kerosene plants making lamp fuel on the east coast.

Edwin Drake drilled America's first oil well in 1859, in Pennsylvania; wells produced more than 500,000 gallons (109 million liters) of this "kerosine" (the spelling was changed to differentiate it from coal oil) the next year. The production of oil quadrupled within a decade.

By the beginning of the 20th Century, energy consumption in America had increased substantially, following the changing character of the U.S. economy. Small towns and villages grew into cities. Industries from food processing to railway car manufacturing became mechanized. The most dramatic change in the American economy came with the invention of the automobile, which altered the entire pattern of land use as well as fuel consumption in America. The first workable gasoline engine, fueled by what was then considered a "useless" by-product of kerosene refining, was developed in Germany in 1877 by Nikolaus Otto. His engine became the model for production of all internal combustion engines, and was first used a decade later in the Benz automobile. In 1903, Henry Ford introduced the gasoline-powered automobile, and set up the first assembly lines of the Ford Motor Company. In the same year the Wright brothers, using a gasoline engine, fulfilled an age-old dream of flying.

There were 8,000 automobiles in the U.S. in 1900; by 1908 this number had increased to 194,000. Within three years, Americans purchased 600,000 of the new machines. By 1930, there were more than 23 million vehicles registered in the U.S.<sup>6</sup>

By the early part of the 20th Century, electricity had become an essential part of American life. It made possible the mass production of appliances, which in turn required electric power to operate. To meet this growing demand larger power stations with higher efficiencies were built. The resulting lower costs to the consumer further stimulated the use and growth of electric power. Since the beginning of World War I total electric power demand has doubled every decade.<sup>7</sup>

In the 20th Century, energy-consuming technology has become integral to the operation of households, factories, and farms. Electrical use by the American public since World War II has more than sextupled, and electricity now accounts for about one-fourth of the nation's energy use. From 1940 to 1971, annual consumption more than tripled—and while the U.S. exported 36 million barrels of oil in 1940, it had to import more than 64 times that amount (2.3 billion barrels) 39 years later. In this same period, natural gas consumption rose from 2.6 trillion cubic feet (73 billion cubic meters) per year to more than 19 trillion cubic feet (.603 trillion cubic meters) and liquid natural gas (LNG) consumption soared from 2.2 billion gallons (8.3 billion liters) to 24.8 billion gallons (93.9 billion liters).<sup>8</sup>

The federal government has been very involved in energy and mineral resource issues. As early as the Mining Act of 1866, which declared public lands to be "free and open" for mining, national legislation has encouraged the exploitation (mining and drilling) of minerals and energy resources, including oil, coal, and uranium. The Mineral Leasing Act of 1920 established the contemporary policies of issuing prospecting permits and leases for exploitation of energy and minerals on public lands.

In 1913 the first federal income tax law permitted "extractive industries" such as the oil industry, an exemption of five percent of their gross income taxes to compensate for the depletion of the resources. Until quite recently, this "depletion allowance" policy remained unquestioned.

The federal government has regulated the price of electricity and natural gas since the establishment of the Federal Power Commission in 1920. In the 1930s the government established the Tennessee Valley Authority (TVA) and the Bonneville Power Administration (BPA), agencies charged with building electrical generation facilities in addition to providing electricity. The Rural Electrification Administration (REA), was responsible for providing electrical service to the rural regions of the United States.

The federal government has regulated the energy industries to some extent through the Justice Department and the Securities and Exchange Commission. Due to violations of Anti-trust laws, the major oil companies (especially Standard Oil Company of New Jersey) were divided into competing companies.

The history of America in this century could be told largely in terms of the increasing use of energy, mineral, and other material resources. The largest jump in consumption was made with the Second World War. The United States was a major supplier of oil and oil-based products to Allied forces. Efforts to meet the war's energy needs initiated the construction of many new oil wells, production facilities, industrial plants, and new synthetic rubber plants. During the war, a scientific team led by Dr. Enrico Fermi built the world's first nuclear reactor, which led to the production of the atomic bomb and to the demonstration of nuclear fission power.

The economic boom following the war coupled with the country's new technological base, expanded U.S. energy use tremendously. Energy-consuming "mechanical" heating and cooling technologies became standard equipment for homes and buildings. The post-war development of the interstate highway system—history's largest public works project—and the popularity of the private automobile helped determine a transportation future linked to petroleum. Every use accelerated as the nation turned from rail transport to highway transport to move freight. Between 1946 and 1968, the U.S. population increased 43 percent, yet electric power consumption increased 276 percent, and motor fuel consumption increased 100 percent. In the past 30 years, changes in transportation, industry, agriculture, and housing have led to very high energy demands.<sup>9</sup>

## Conventional Energy Systems (2.2)

The development of centralized energy systems in the U.S. economy occurred during a period when less-centralized energy sources such as hydro-power, windmills, and wood-fired processes were not capable of providing the vast amount of energy required by a rapidly industrializing society. The lack of precision in prime movers and early power machinery favored use of large amounts of fossil fuel for transportation and power processes. The energy could not be readily supplied by locally-available hydropower and biomass fuels.

This section describes in some detail the components of modern liquid and solid fuel systems, as well as electric utility systems. Conventional energy systems for petroleum, natural gas, coal, nuclear, and electric plants are summarized and future paths are indicated, illustrating the degree of dispersal and decentralization in these systems (synfuels, future power plants, etc.).

From a strategic energy perspective, understanding the possibilities for dispersal within the larger systems is a significant first step towards designing alternative approaches and for downsizing units for use in community-based systems.

### Petroleum (2.2-1)

Almost 74 percent of the energy supply in the United States in 1979 came from oil and natural gas.<sup>10</sup> U.S. dependence on petroleum and gas has grown on the strength of three basic qualities of these fuels: (1) as resources they have been readily available; (2) they are very concentrated energy sources; and (3) they are easily transported.

Petroleum is America's premier fuel. It fuels transportation, converts to electricity, heats homes, powers industry and is also an important raw material in petrochemicals. A host of essential products are made from petroleum, including fertilizers, pesticides, medicines, industrial chemicals, and lubricants.

The technology for all fossil fuels begins with exploration, an expensive and time-consuming process based on trial and error. Suspected reserves of oil, gas, or coal can be confirmed only by actual drilling. More than one-fourth of the entire land area of the United States is now under lease for oil and gas exploration.<sup>11</sup>

The sites for energy consumption tend to remain constant because they are based on factors such as population, weather, industrial activity, and location of other resources. The sites for energy supply however, may change over a period as short as several years. America's current major energy supply region, the Gulf Coast area, has apparently reached its peak as a supplier of oil and natural gas, and is rapidly becoming a major energy consumer because of its concentration of refineries and shipping facilities.<sup>12</sup> Major new sources of domestic crude oil appear to be in Alaska and on the Atlantic and Pacific Outer Continental Shelves.

Extraction of petroleum is complicated by great variations in the configuration of deposits and the surrounding geology. Early oil wells were easily tapped by drilling to a pool relatively near the surface. Today secondary and tertiary recovery methods are being applied to oil fields which have been drilled a first time. These methods include injection of water or gas under high pressure into additional wells to force the oil toward the producing holes, or the use of detergents, solvents, or underground combustion to loosen the oil from rock.

American oil wells pump about 8.5 million barrels of oil per day which supplies approximately 48 percent of what the U.S. needs. U.S. domestic production has fallen 9.6 percent from its peak in the early 1970s. In 1979, U.S. domestic production of crude oil totaled 3.1 billion barrels; imports were up to 2.3 billion barrels that same year, equalling a total consumption of 6.4 billion barrels.<sup>13</sup>

Estimates of future availability of oil vary widely. Figures used by geologists are reserve figures. The U.S. Geological Survey defines a reserve as "that portion of the identified resource from which a usable mineral and energy commodity can be economically and legally extracted at the time of determination."<sup>14</sup> The United States is known to have 35.3 billion barrels of petroleum reserves, or about five percent of the known total world reserve of oil.<sup>15</sup> In addition, geologists estimate the quantity of undiscovered resources which may exist. An undiscovered resource is defined as an "unspecified body of mineral-bearing material surmised to exist on the basis of broad geologic knowledge and theory; in other words, a guess at probable supplies based on geological data."<sup>16</sup> Estimates of U.S. undiscovered recoverable petroleum resources range from 55 billion barrels to 456 billion barrels. At the current (and constant) rates of consumption of six billion barrels per year, the U.S. domestic oil supply is predicted to last between one and seven decades.

As can be seen in Table 2.2-1, Texas remains the nation's largest producer of crude petroleum with more than a billion barrels in 1979. Alaska produced about half as much that same year, with Louisiana running third in terms of production. California, Wyoming, and New Mexico are major oil producers.<sup>17</sup> Table 2.2-1 also evidences the decline in American production. Production steadily decreased through 1977, but began to rise in 1978.

The United States now imports 6.4 million barrels of oil daily (36 percent) to help meet national consumption of 17.8 million barrels per day.<sup>18</sup> The U.S. Department of Energy expects this trend to continue until Alaskan oil makes a more substantial contribution to U.S. supply. The total amount of Alaskan oil that we can expect to recover has been estimated by the U.S. Geological Survey to be eleven billion barrels.<sup>19</sup> If Alaska were our sole source of oil, and we used it at current consumption rates--without allowing for increases--the U.S. would deplete the Alaskan resource in less than two years. America's offshore resources are estimated at six billion barrels, about one year's supply of oil at the current rate of consumption.<sup>20</sup>



Table 2.2-1<sup>21</sup>

U.S. CRUDE OIL PRODUCTION  
(THOUSANDS OF BARRELS)

	<u>1973</u>	<u>1979</u>
Alaska	77,323	511,538
California	336,075	352,465
Louisiana	831,529	494,462
New Mexico	100,986	79,379
Texas	1,294,671	1,013,255
Wyoming	141,914	124,553
Other	<u>578,405</u>	<u>538,901</u>
TOTAL	3,360,903	3,114,553

The international sources of oil will assume even greater importance as domestic sources are depleted in coming years. At present, U.S. oil reserves represent about 7.2 percent of the world's recoverable reserves. The Soviet Union's oil reserves represent 14.3 percent of the world's petroleum reserves.<sup>22</sup> More than one-half of the recoverable oil in the world is concentrated in the region of the Persian Gulf.<sup>23</sup>

Contributions of foreign petroleum to the U.S. energy system come from many sources, and enter the system through ports throughout the country where it is distributed to the industrial Northeast by pipeline. The U.S. imports a major portion from the Middle East, including Iraq, Saudi Arabia, the Arab Emirates, Kuwait, Qatar, Oman, Bahrain, Turkey and Yemen.

The U.S. also receives substantial imports from South America, principally from Venezuela. We receive almost as much from Africa and the Caribbean, principally Trinidad-Tobago and the Netherlands-Antilles. The United States also imports petroleum from Europe including the Netherlands, Spain, Italy, Romania, West Germany, the U.S.S.R., England, Belgium, Finland, France, Greece, Portugal and Denmark, as well as Asia, (principally from Indonesia) and lesser amounts from Canada, Central America and Australia.<sup>24</sup>

In addition, the United States imports refined petroleum products<sup>25</sup> principally residual fuel oil and boiler fuel—from Caribbean and European refineries. In 1979 we imported from all sources a total of 730 million barrels of refined petroleum products.

As a hedge against the vagaries of world oil politics, U.S. energy planners are determining ways to increase domestic production. Aside from the production of oil from known reserves, a number of existing methods (and some proposed methods) have been advocated for producing oil from deposits not heretofore considered economically recoverable.

Techniques known as "secondary" and "tertiary" recovery methods recover additional oil from old, near-depleted wells. In the early days of oil drilling, gas and water pressure alone forced oil to the surface. In the 1930s oil producers began to use a secondary recovery process called water flooding, which pumped water into one well to force oil out of adjacent wells. This technique enabled a recovery rate in excess of the usual twenty percent. Today, about half of the nation's oil is produced using secondary techniques, and the average yield has risen to 34 percent of an oil field's resource total.

The oil industry first attempted tertiary processing in 1952. Tertiary processes are a variation on the water flooding techniques, substituting various chemicals for water. The techniques have never proven economical and today only a few thousand barrels per day are produced in pilot plants.

Several new techniques for tertiary oil recovery have been developed, including the injection of various gases, steam, carbon dioxide, and exotic chemicals. Successful tertiary techniques could add between 30 and 60 billion barrels to potential U.S. reserves, assuming that today's recovery rates can be raised seven to thirteen percent.<sup>26</sup> A basic limitation of all schemes to increase oil recovery by these techniques is the energy required to recover the oil. If the additional investment in energy and materials necessary for tertiary recovery is higher than the energy return from the oil or gas recovered, then there will be a net energy loss.

Almost all of the petroleum used in the United States requires transportation at one time or another. Of the 4.43 billion barrels of crude oil consumed by the U.S. in 1974, all but 45 million barrels were moved through the national energy transportation system.

Whether from sites of domestic production or points of importation, crude oil is transported to refineries as the next step in the petroleum fuel cycle. Once refined, it is transported to markets in much the same manner by pipeline, water carriers (tankers), motor carriers (trucks), or railroad tank cars.

Most domestic crude oil moves by pipelines. According to the Bureau of Mines, the U.S. has 60,800 miles (97,827.2 km) of crude trunk pipelines as of January 1, 1974. In addition, there were 36,5000 miles (58,728 km) of gathering pipelines bringing crude oil from individual wells and fields to common points for storage, refining, or trunk pipeline transport.<sup>27</sup> Figure 2.2-1 illustrates the total petroleum movement network for the continental U.S.

Water transport of crude oil has declined because of competition from motor carriers by still accounts for about thirteen and one-half percent of total transportation. Motor carriers moved about eleven percent of U.S. crude oil in 1974; railroads moved less than half of one percent.<sup>28</sup>

Crude oil is rarely used in its original form; it is almost always refined to some extent. Like oil production, oil refining is centered in the Gulf Coast region. In 1979, about 38 percent of the U.S.'s 5.6 billion barrels of petroleum products were refined there, mostly in Texas (1.463 billion barrels). The Great Lakes and Middle Atlantic regions account for another nineteen percent. Most other states do at least some refining.<sup>30</sup>

Table 2.2-2 shows the typical range of products refined from one barrel of oil. Refineries do vary the composition of products seasonally to some extent: for example greater concentrations of gasoline are refined in the summer for vacation travel.<sup>31</sup>

Table 2.2-2<sup>32</sup>

WHAT A REFINERY DOES WITH AN AVERAGE BARREL  
OF CRUDE PETROLEUM

<u>Product</u>	<u>Percentage of Oil</u>
Gasoline	39
Distillate oils (diesel fuel & heating oil)	18
Residual fuel oil (for industry & power plants)	14
Lubricating oil, asphalt, petrochemicals	11
Propane, butane, and other gas products	8
Jet fuel	6
Consumed in refinery operation	4

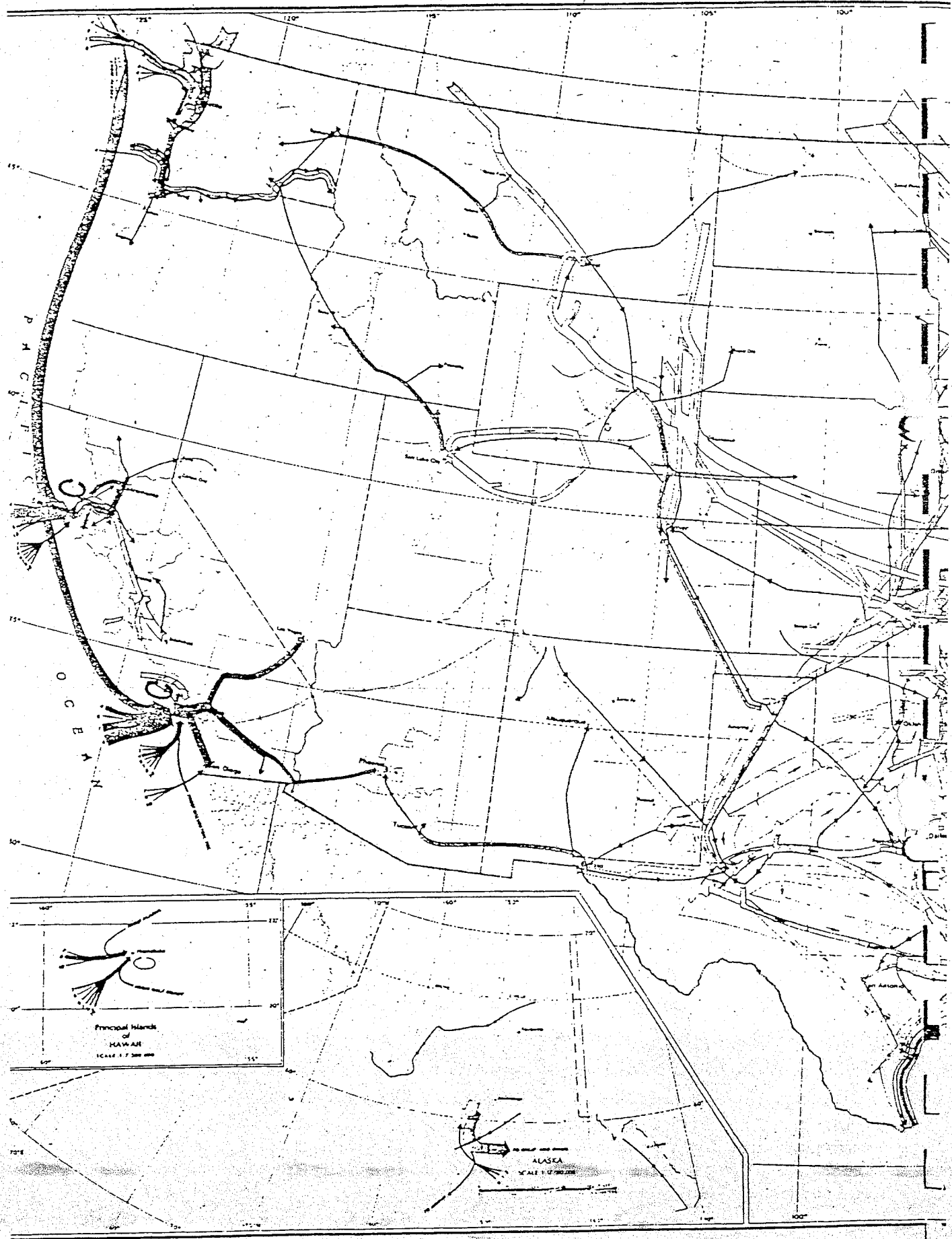
The distribution of refined petroleum products from the Gulf States to the Southeastern and North Central States is by pipeline, to New England by water, to Florida by water, to California by pipeline, and within California by truck. Interstate and regional movement of petroleum products is principally by truck.<sup>33</sup>

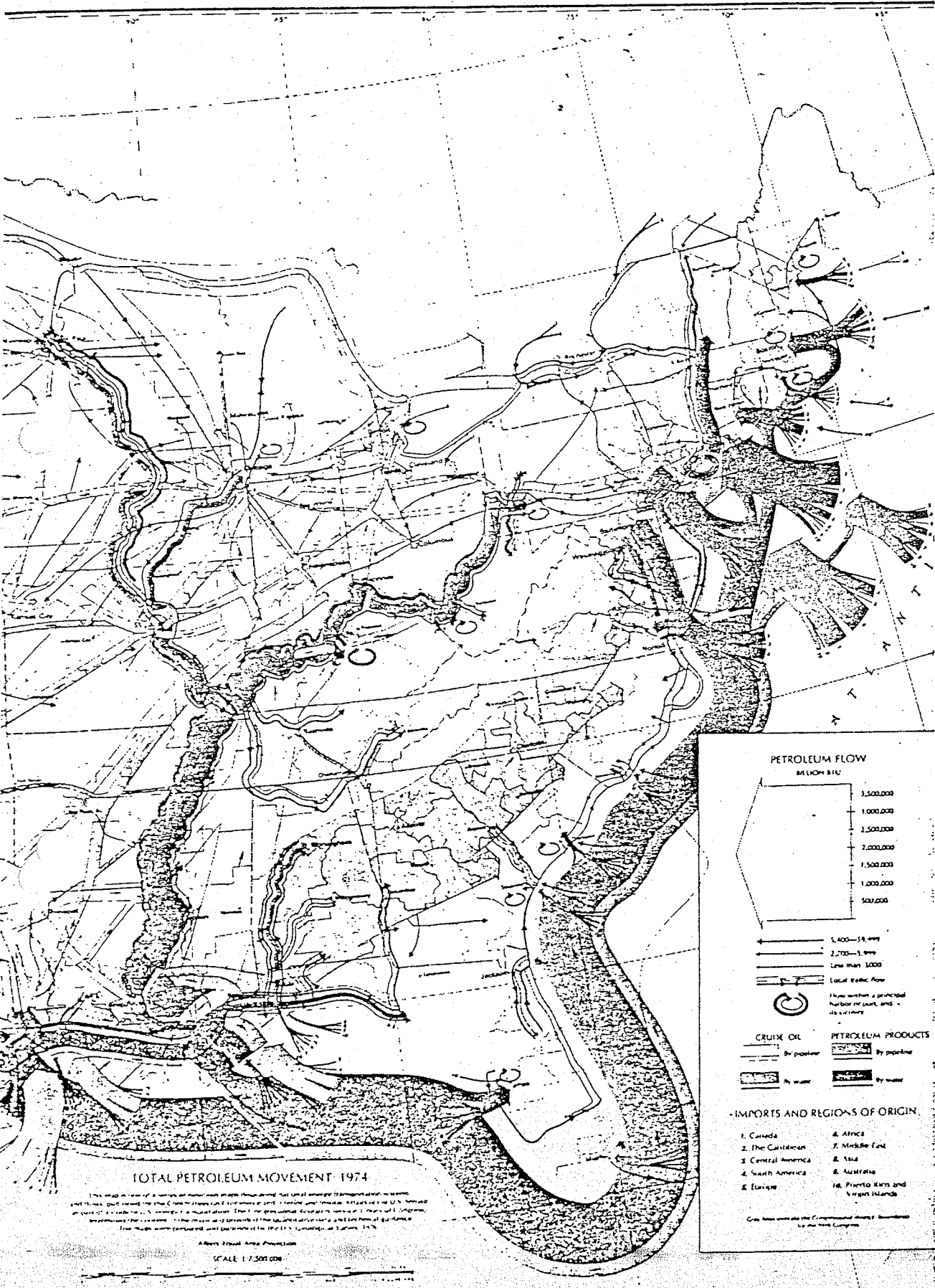
The basic movement of all petroleum is north and east from the Gulf region toward industrial and population centers. Petroleum contributed 47 percent of the total U.S. energy supply in 1979, including imports and domestic production.<sup>34</sup> Imported petroleum is particularly important to the Northeast, because of its lack of indigenous resources, and the Gulf region, where it is substituted for declining domestic supplies.

Within the United States, California and New York are the two greatest consumers of refined petroleum, followed by Texas, Pennsylvania, and Illinois. These same states, plus Ohio, also consume the most gasoline. The greatest quantity of distilled fuel oil, used predominantly for home heating, is consumed by New York, Pennsylvania, New Jersey, Massachusetts, and Texas. New York, California, and Florida lead the nation in consumption of residual fuel oil which is used to fire boilers. The same trends are apparent for jet fuel, asphalt, liquid petroleum gas (LPG) and ethane. Rural states such as Missouri, Iowa, and Indiana, where LPG and ethane are important in supplying energy to many farms, are also major consumers of these fuels.<sup>35</sup>

Figure 2.2-1<sup>29</sup>

TOTAL PETROLEUM MOVEMENT MAP



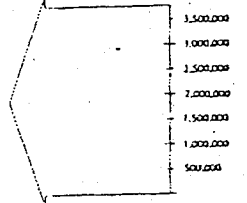


**TOTAL PETROLEUM MOVEMENT 1974**

This map is one of a series of maps showing the total energy transportation system and flows. It is based on the Census Bureau's 1974 Energy Survey. It shows the movement of petroleum products from the oil fields to the refineries and then to the consumers. The map is a composite of the oil and gas pipelines and the flow of petroleum products. The map is based on the Census Bureau's 1974 Energy Survey. The map is a composite of the oil and gas pipelines and the flow of petroleum products.

Albert Road Area Protection  
SCALE 1:7,500,000

**PETROLEUM FLOW**  
BILLION BTU



- ← 1,400—19,999
- ← 2,700—19,999
- ← Less than 1000
- ← Local Basic Flow

Circle with a horizontal bar or part, and its primary

- |                  |                           |
|------------------|---------------------------|
| <b>CRUDE OIL</b> | <b>PETROLEUM PRODUCTS</b> |
| By pipeline      | By pipeline               |
| By water         | By water                  |

**IMPORTS AND REGIONS OF ORIGIN**

- |                    |                                    |
|--------------------|------------------------------------|
| 1. Canada          | 6. Africa                          |
| 2. The Caribbean   | 7. Middle East                     |
| 3. Central America | 8. Asia                            |
| 4. South America   | 9. Australia                       |
| 5. Europe          | 10. Puerto Rico and Virgin Islands |

Gray lines indicate the Compressional Energy boundaries for the West Coast.

## Natural Gas (2.2-2)

Clean-burning natural gas, once regarded as a nuisance by-product of oil wells, is now an important residential, commercial, and industrial fuel, as well as a favored fuel for electrical generation. Since 1900, consumption of natural gas has grown steadily (see Figure 2.2-2) outdistancing coal and falling just short of petroleum. Natural gas now supplies nearly 25 percent of overall energy demand in the U.S.<sup>36</sup> A major reason for its popularity may be its relative lack of polluting emissions when burned.<sup>37</sup>

The estimates of undiscovered domestic natural gas resources are as disparate as the estimates of oil resources. Estimates range from a maximum of 2,000 trillion cubic feet (52.5 trillion cubic meters) of gas to a minimum of 374 trillion cubic feet (10 trillion cubic meters). The total natural gas reserves in the U.S. in 1978, according to the Energy Information Administration (EIA) of the DOE, were 200 trillion cubic feet (5.5 trillion cubic meters). According to the EIA, current annual consumption is over 19 trillion cubic feet of gas per year, which leaves less than eleven years of proven gas reserves.<sup>38</sup> It is estimated that 26.2 percent of the world's total remaining natural gas reserves are located in the Persian Gulf. Only the Soviet Union has more estimated future gas reserves with 31.8 percent of the world's total. Domestic natural gas equals only 9.3 percent of the world's total.

The 1976 Department of Energy estimates suggest that Alaskan gas might supply somewhat more than one trillion cubic feet (30 billion cubic meters) before 1985, and imports of gas (shipped to the U.S. in liquified, cryogenic container-ships) might supply two trillion cubic feet by that year. This projected supply comprises thirteen percent of current U.S. consumption of natural gas in one year.<sup>39</sup>

Natural depressurization of an underground reservoir forces gas upward through producing wells. Because of natural underpressurization or gradual loss of natural pressure, a large fraction of the available gas at most wells must be used to pump the remainder out of the ground.<sup>40</sup>

Texas and Louisiana supply most of the natural gas to the rest of the United States. Together the two states produced 70 percent of the total national marketed production in 1978. Texas and Louisiana are also first and second, respectively, in consumption of natural gas. Oklahoma, Kansas and New Mexico contributed nineteen percent of total national gas supply in 1978. These five states continue to produce about 90 percent and consume 40 percent of national supply.<sup>41</sup>

Domestic U.S. production of natural gas is greater than domestic production of petroleum. Domestic production of both peaked and began to decline in the early 1970s. This decline has resulted in increasing curtailments of interstate natural gas commerce, though there is still substantial interstate commerce in producing states.<sup>42</sup>

To compensate, the United States is beginning to import liquified natural gas (LNG) and gasify domestic coal. Liquification of natural gas enables it to be stored and shipped compactly and in very large quantities. Natural gas liquifies when it is chilled to  $-162^{\circ}\text{C}$  ( $-259^{\circ}\text{F}$ ). This reduces its volume more than 600 times, meaning



that one tank of LNG contains about 600 times the amount of energy contained in a tank of regular natural gas. This tremendous concentration, plus the fact that LNG vaporizes on contact with air, means that it must be shipped with extreme caution.<sup>43</sup>

Most LNG comes to the U.S. in supertankers from Algeria, the principal exporter of LNG. Libya and Indonesia are also major exporters.<sup>44</sup> Tankers carrying LNG are of highly specialized design. Spherical tanks or "membrane" tanks carry the LNG within the hull of the ship. Because of economies of scale, the size of these tankers has grown over the years, until they are now up to 1,000 feet (304.8 meters) long with cargo tanks up to 100 feet (30.5 meters) tall. Such tankers cost approximately \$200 million apiece. The world fleet of these ships is estimated at 79 vessels. Their standard cargo capacity is 125-130,000 cubic meters; ships with a capacity of 200,000 cubic meters are now on the drawing board. The standard cargo capacity is enough to heat 2.5 million homes on a 22°F (-5.6°C.) day or to provide electricity for a city of 85,000 people for one year.<sup>45</sup>

The United States has one export terminal at Kenai, Alaska where LNG is distributed to the lower 48 states. Two other Alaskan terminals are planned, at Cook Inlet and Point Gravina. Various gas companies maintain import terminals at Elba Island, Georgia; Cove Point, Maryland; and Everett, Massachusetts. There are proposals for more import terminals at Point Conception, California; Lake Charles, Louisiana; West Deptford, New Jersey; Staten Island, New York; Newport, Oregon; Providence, Rhode Island; and Port O'Conner and Ingleside, Texas.<sup>46</sup>

Once imported, LNG is stored at either large "peak-shaving" stations or small satellite stations. Peak-shaving plants store LNG that gas companies buy at low summer rates and then resell at times of peak winter demand. There are now 63 such plants in the United States.<sup>47</sup> Peak-shaving plants in turn supply LNG to smaller satellite facilities in more remote areas. There are about 60 of these facilities in the U.S.<sup>48</sup>

Both types of facilities employ double-walled, insulated tanks to keep the LNG at its required low temperature. The tanks rely on insulation to maintain the temperature, rather than on power refrigeration. Most tanks are made of specially alloyed metal; others are constructed with pre-stressed concrete. Some tanks hold as much as 50,000 cubic meters of LNG. A few hold more than 100,000 cubic meters. Tanks are large because of economies of scale, because they take up less space in urban areas, and because there is less loss from boiling-off LNG reverting to gas and dispersing.<sup>49</sup>

Tank trucks deliver LNG to the satellite stations and also supply liquified gas for industrial applications. About 75 trucks have an average capacity of 10,200-12,500 gallons of LNG (38-47 cubic meters); they travel up to 1,500 miles (2,414 km) for deliveries.<sup>50</sup>

Domestic supplies of natural gas are transported primarily by pipeline. The United States maintains a system of natural gas pipelines which carry large amounts of gas within producing regions and to major consuming regions. These pipelines extend to every continental state except Vermont. Long distance transportation of natural gas became possible with the introduction of welded gas pipelines in 1925.<sup>51</sup>

In 1979, the United States consumed 19.5 trillion cubic feet (.4 trillion cubic meters) of natural gas.<sup>52</sup> Fifty billion cubic feet (1.3 billion cubic meters) of it moved around the U.S. in pipelines owned by 34 interstate natural gas pipeline companies. As of 1979, there were 341,247 (549,066 km) miles of natural gas transmission pipelines, field and gathering lines, and an additional 688,480 (1,107,764 km) miles of distribution mains.<sup>53</sup> The U.S. natural gas pipeline network is shown in Figure 2.2-2.

The typical natural gas pipeline is 30 inches (.76 meters) in diameter and about 1,000 miles (1,609.3 km) in length. Some are as wide as 48 inches (1.2 meters). Pipelines are buried and are invisible above ground except for right-of-way markers and occasional compressor stations.

The natural gas "grid" consists of the lines and interconnections between cross-country pipelines. It is formalized among companies by proprietary agreements and fraught with institutional barriers. The nation's natural gas supplies are managed by many small, independent gas companies who would have to forfeit some control of their operations if a grid were to exist, and they are reluctant to do this. The interconnections that exist now are meant to be used for only a short time for instance, in emergencies or for sales or exchanges between companies.

Underground storage facilities which are the preferred method of storage, are usually natural formations such as salt mines, aquifers, or fully depleted oil and gas wells. The average capacity of underground storage pools is about nineteen billion cubic feet. In 1978, there were 388 such storage facilities in the U.S. There are also 53 underground storage aquifers, with an average capacity of 30 billion cubic feet (.8 billion cubic meters). Approximately half of the states in the U.S. use underground pools, and about ten states use aquifers. States in the East North Central, West South Central, and Middle Atlantic regions make the most use of underground natural gas storage.<sup>54</sup>

Gas companies try to store their peak-shaving supplies near the areas where they will be consumed. Most storage areas are a few miles away from the towns that use them. Companies use the smaller distribution main pipelines to transport natural gas from storage areas into the homes and businesses of their customers.

Twenty percent of the energy the U.S. consumed in 1979 was in the form of natural gas. Per capita consumption of natural gas began to decline in 1972, but increased slightly in 1978 by 1.7 percent. Small increases in the residential and commercial sectors were offset by a larger decrease in the industrial sector.<sup>55</sup>

States rely on natural gas to varying degrees. In some states gas is used principally for heating homes and domestic water, and for cooking; in others it is used for electrical generation or high-temperature industrial processes.

Industry is by far the biggest overall consumer of natural gas. In 1979, 8,636 trillion Btus were used. Almost half of the energy that industry uses is natural gas. Residential and commercial uses of natural gas amounted to 7,770 trillion Btus in 1979, and utilities used 3,610 trillion Btus to generate electricity.<sup>56</sup>

### Coal (2.2-3)

Commercial coal mining in the U.S. began about 1750 near Richmond, Virginia. The first expansion of coal mining began with the rise in iron and steel production during the Civil War. By 1885, railroads were the greatest consumers of coal. When the railroads converted to diesel electric locomotives, the electric power generating companies stepped in as the major consumers of coal. Decline in the use of anthracite coal for space heating and cooking was offset by an increased use of bituminous coal by the iron and steel industries. However, overall coal use has dwindled rapidly since 1910 from about 70 percent of U.S. energy use to about 18 percent in 1979, having been displaced for most uses by oil and gas.<sup>58</sup>

Pressures to reduce dependence on foreign oil and uncertainties about nuclear power's ability to provide a fraction of U.S. electric demand are again bringing coal to national attention.

Utilities and energy planners (principally the U.S. Department of Energy) are looking to the nation's tremendous domestic reserves of coal to be the primary source of energy for the nation's electric power plants--for new plants, and replacing oil in some oil plants. This increased use of coal will not be without a number of attendant environmental problems.

Nevertheless, the U.S. government, through several important pieces of legislation, is encouraging utilities and private industry to convert from the use of oil and gas to coal. The Power Plant and Industrial Fuel Use Act requires utilities to use fuels other than oil or gas in new utility boilers after 1990.<sup>59</sup>

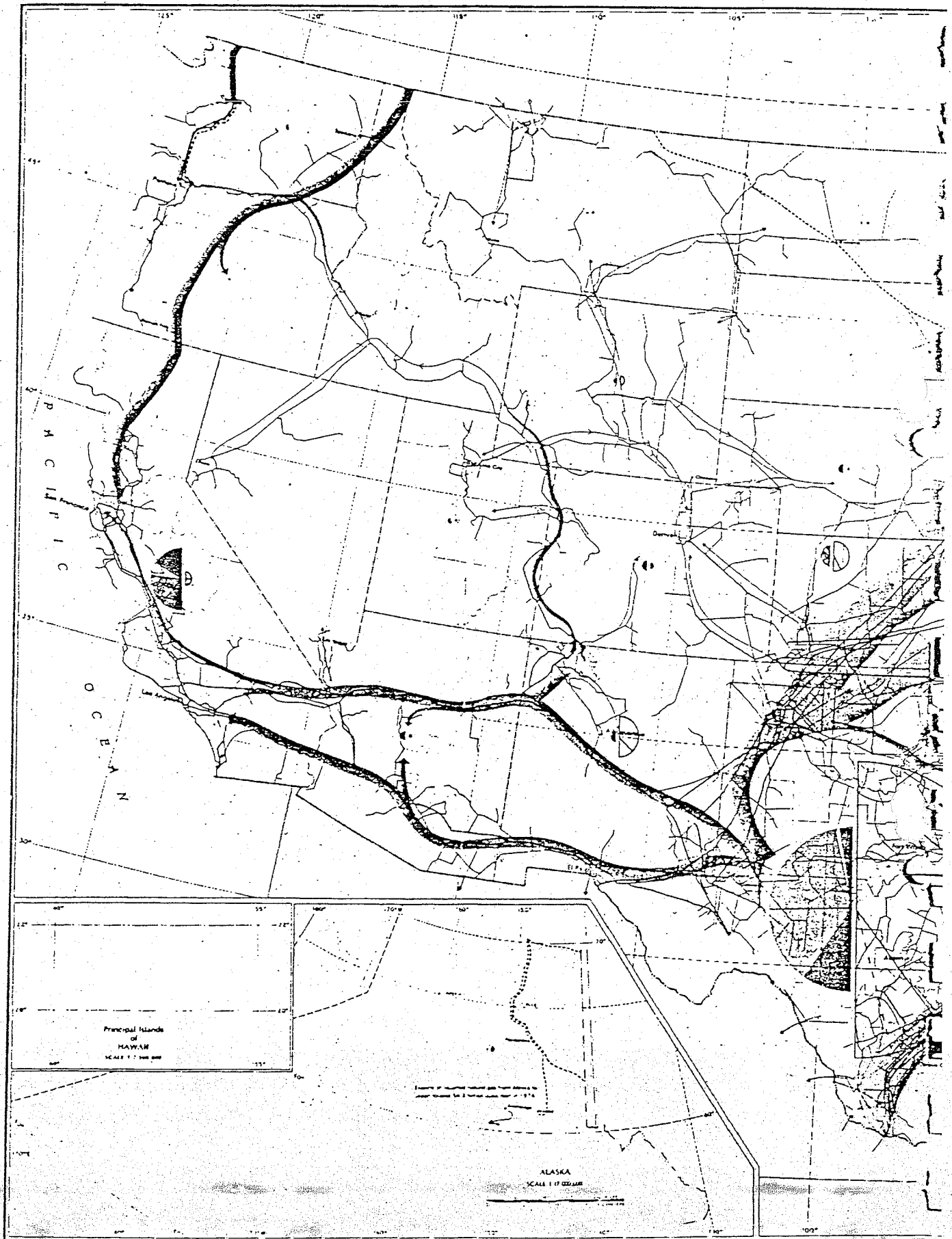
The U.S. Geological Survey and the U.S. Bureau of Mines estimate that the U.S. holds 1.5 trillion tons (1,360.8 trillion kg) of coal at depths to 3,000 feet (914.4 meters) and in seams at least fourteen inches thick. The Bureau of Mines considers 136.7 billion tons (124,012 billion kg) economically recoverable with current mining technology. The remainder could only be mined using sophisticated deep-mining techniques, since the deposits are either too deep for surface mining or the seams too thin to be effectively surface-mined.

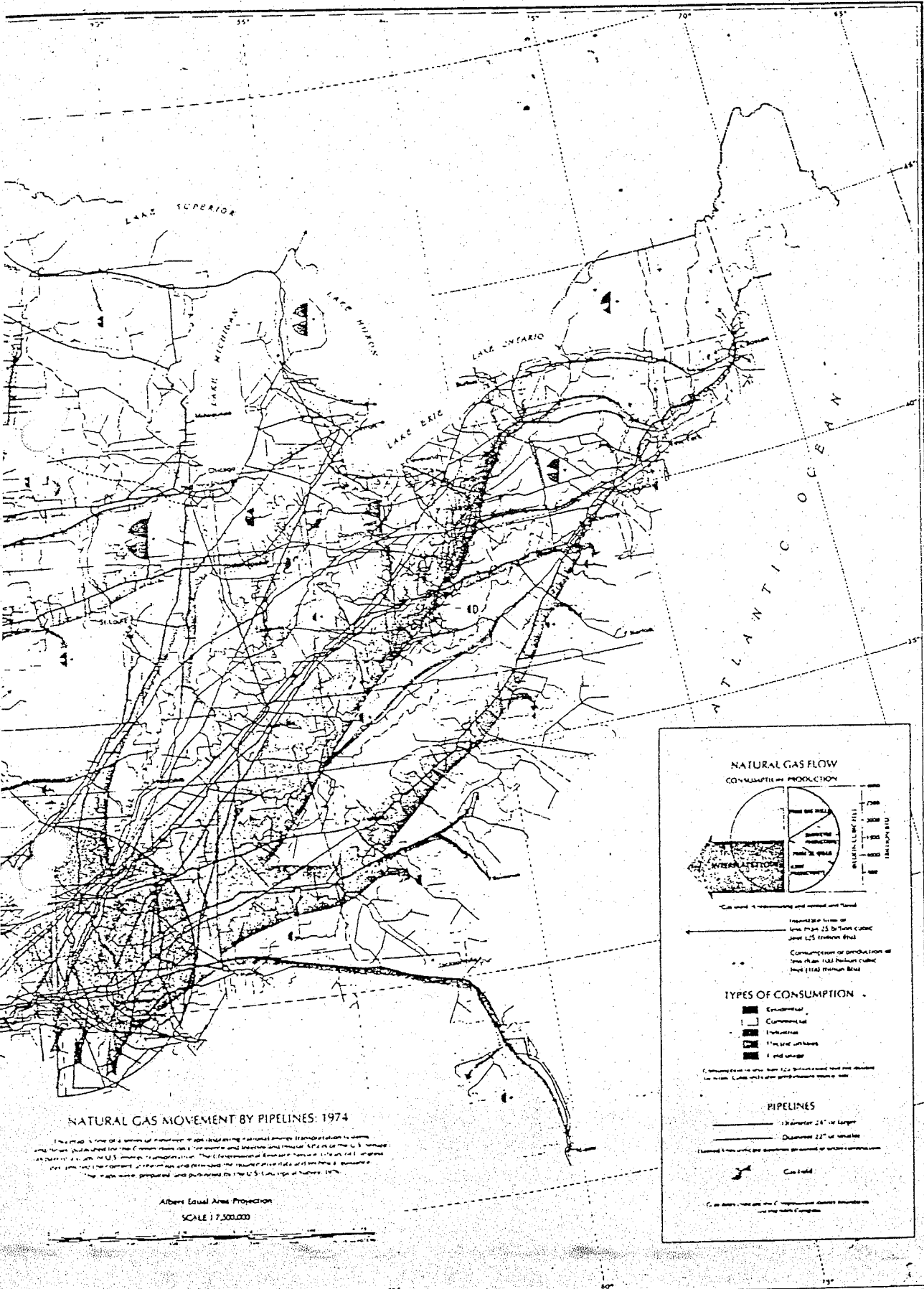
Coal is the most plentiful fossil fuel in the United States. It represents about 88 percent of the proven reserves of all U.S. fuels. Extensive deposits of coal are found in the eastern, central and western United States, including high-grade coal resources in Alaska. The states with the greatest known resources of minable coal are Montana, Illinois, West Virginia, Pennsylvania, and Kentucky. Thirty states in all have been identified by the Department of the Interior as having minable coal resources.

About 70 percent of the coal in the U.S. is located west of the Mississippi. However, much of the western coal is low in energy value, high in sulfur content, and must be strip-mined. Anthracite coal has an average moisture content of five percent and a sulfur content of 0.7 percent or less. Subbituminous coal has an average 25 percent moisture content and sulfur ranging from two percent to 0.7 percent (and less.)

Figure 2.2-2<sup>57</sup>

NATURAL GAS MOVEMENT MAP

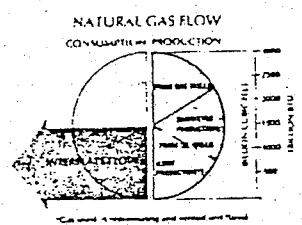




**NATURAL GAS MOVEMENT BY PIPELINES: 1974**

This map is one of a series of maps illustrating natural gas transportation systems and routes published by the Census Bureau, the Bureau of Economic Analysis, and the U.S. Energy Information Administration. The information shown here is based on data collected by the U.S. Energy Information Administration. The maps were prepared and published by the U.S. Census Bureau in 1974.

Albers Equal Area Projection  
SCALE 1:7,500,000



Consumption or production of more than 1,000 billion cubic feet (100 billion cubic feet) per year

**TYPES OF CONSUMPTION**

- Industrial
- Commercial
- Residential
- Manufacturing
- Other

**PIPELINES**

- Diameter 24" or larger
- Diameter 22" or smaller

Gas field

Of the various types of coal, anthracite is of the highest energy quality, followed by bituminous, subbituminous, and lignite. Anthracite is found largely in Pennsylvania (although there are substantial Alaskan deposits) and has an energy value of 14,000 Btus per pound. Subbituminous coal contains an energy value of 9,500 Btus per pound and lignite yields 6,100 Btus per pound.

Ownership of coal reserves is split among three interests: energy companies; the railroad industry; and coal consuming industries which include electric, steel, other metals, and chemical industries.<sup>60</sup> The locations of most coal beds is known. Factors such as rank, ash content, continuity, thickness, and depth remain to be discovered.

The major questions surrounding coal reserves are where and how coal will be extracted and used. A 1973 study by the Library of Congress indicated that 30 billion tons (27,215.5 billion kg) of low-sulfur (one percent or less) strippable reserves exist in the West, compared to only 1.8 billion tons (1,632.9 billion kg) in the East. However, there are an additional 82 billion tons (74,389.1 billion kg) of low-sulfur reserves in the East, half of which are recoverable with current deep mine techniques.<sup>61</sup> Coal in the West is primarily recoverable by stripmining techniques. Energy planners are looking with interest at western coal, and several conversion technologies have been proposed for exploiting these deposits. Development plans for using western coal involve stripmining and transporting coal by unit-trains (specially designed long freights, carrying only coal) to consuming areas, or mixing pulverized coal with water and transporting the resulting "slurry" via pipeline to consuming areas.

Strip mining is the least expensive and most efficient means of mining coal. It is done by stripping overlying material away from a minable coal seam with large electric shovels, and blasting the coal into chunks with explosives. Most strip mines are less than two hundred feet deep. Strip mines produce as much as 15,000 tons (13,607,771.1 kg) of coal a day and employ as many as 700 men in a single mine.<sup>62</sup>

Underground mining is the traditional method of mining coal. Historically mine shafts were dug to intersect coal seams, and miners would drill or blast into the coal seam and then load carts full of broken coal and push them to the surface. Now much of this operation has been mechanized. Continuous mining machines cut rather than blast the coal, break it and move it continuously into waiting cars. Most underground coal mines are less than 3,000 feet deep. produce from two to three tons to 10,000 tons, and employ one to two thousand men per mine.<sup>63</sup>

More than half of the coal mined in the U.S. in the mid-1970s came from surface mines. However, coal that can be mined using surface methods comprises only 30 percent of U.S. coal reserves and ten percent of the estimated coal resources. About a quarter of U.S. coal comes from underground mines; the remainder is mined with augers which bore into coal seams exposed on hillsides.<sup>64</sup>

Improvements in deep mining technologies such as the development of the continuous mining machine, have helped reduce the labor-intensity of deep mining. Other advanced deep mine technologies, called "longwall" and "shortwall" systems, have eliminated the older "roof and pillar" methods, enabling recovery of up to 90 percent of the coal in a seam with current techniques.<sup>65</sup>



Coal is still a plentiful domestic resource; in 1979, the U.S. exported 59,874 million kg of coal and imported only 1,814 million kg.<sup>66</sup> Australia and South Africa provided 72 percent of total U.S. coal imports in 1978. Other suppliers are Canada, Poland, West Germany, and the Netherlands.<sup>67</sup>

Most use of coal involves significant transportation, which affects its delivered price more than other fuels. This, in turn affects the need for different varieties of coal, the working of the spot and long-term delivery markets, private ownership of some production and transportation capacity, and perhaps seasonal fluctuations of supply in demand.<sup>68</sup>

Coal is transported mainly by railroads, water carriers, and trucks. Coal slurry pipelines (carrying coal suspended in water) are becoming an important alternative. Several slurry pipelines are planned and one is now operating. About half of U.S. coal production moves by rail, a quarter by water, and about ten percent by truck. The rest is consumed at the mine-mouth.<sup>69</sup> Figure 2.2-3 shows total coal movement in the U.S.

It is significant that all of these transportation modes, with the exception of the pipelines, depend on diesel fuel. According to the Congressional Research Service, "...our dependence on overseas sources for half of the oil we use may threaten our supply lines for coal as well."<sup>70</sup>

The single largest movement of coal in the U.S. is transport of metallurgical coal by rail from the Appalachian region to Virginia for export, followed by transport of steam coal from that region to North Carolina. Large amounts also move from Appalachia to Ohio and Michigan, and to New York and New England from Pennsylvania, and interstate in Pennsylvania, Illinois, Indiana, Kentucky, Ohio, and West Virginia. Long shipments come from Wyoming and Montana to the Midwest.

Trucks move coal in smaller amounts and over shorter distances. Trucks are used similarly for interstate transportation in such states as Pennsylvania and Ohio. The principal route for barge traffic is the Ohio river, and the Atlantic coast is the shipping point for exports.

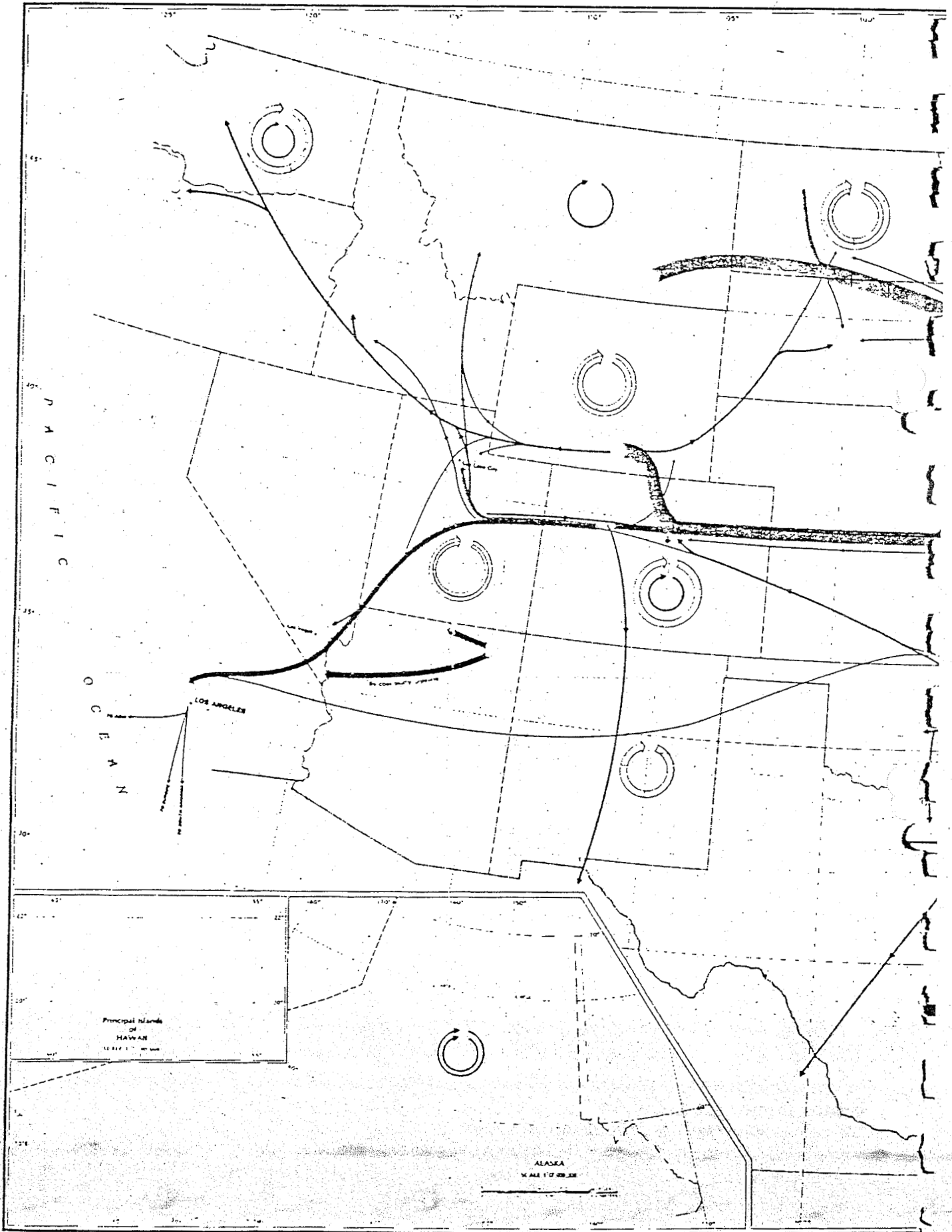
Coal is not actually refined, but more than half of the coal used in the U.S. is cleaned before it is burned or processed in order to remove ash and inorganic sulfur. Sulfur oxides are a serious pollutant, and clean coal is best for gasification.

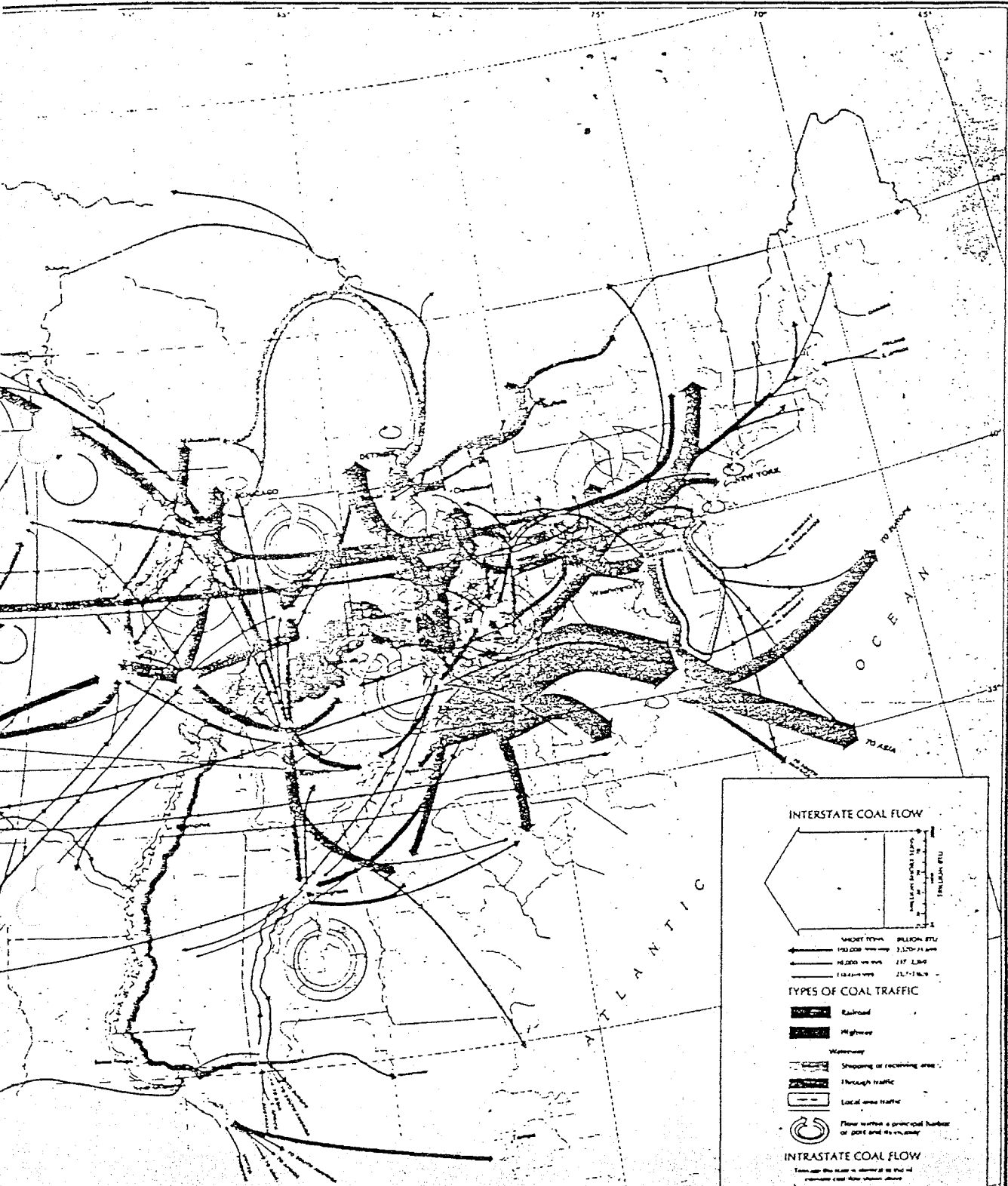
Coal technology is changing as its place in the U.S. energy picture changes. In the last century, when oil replaced coal as an industrial fuel, coal was relegated to use by power plants, which burned it directly. Now recently devised technologies such as fluidized-bed burning have improved the efficiency of coal use, and techniques such as coal gasification make coal available as gaseous as well as solid fuel.

The availability of water may be the major limiting factor in future coal exploitation. A study by the National Academy of Sciences (NAS) found that, even by using watersaving technologies such as dry cooling towers in a coal-fired power plant and other conversion facilities, the water supplies for these uses "are not normally available at coal mine sites in the western United States. In most coal-rich areas the local supply of ground or surface water is insufficient to meet the consumptive use requirements in conventional energy conversion processes."<sup>71</sup>

Figure 2.2-372

COAL MOVEMENT MAP





**TOTAL COAL MOVEMENT: 1974**

This map is one of a series of thematic maps displaying national energy transportation systems. They have supported the new U.S. energy program and are part of a series of maps published as part of a new series of energy maps. The U.S. Department of Energy is responsible for the data and the maps are published by the U.S. Geological Survey.

Albers Equal Area Projection  
SCALE 1:7,500,000



**INTERSTATE COAL FLOW**

Symbol	Value	Unit
Thick line	100,000,000,000	BILLION BTU
Medium line	10,000,000,000	BILLION BTU
Thin line	1,000,000,000	BILLION BTU

**TYPES OF COAL TRAFFIC**

- Railroad
- Highway
- Waterway
- Shipping or receiving area
- Through traffic
- Local area traffic
- Flow within a principal harbor or port and its vicinity

**INTRASTATE COAL FLOW**

Through the state is shown as that of interstate coal flow shown above.

- Major flow by railroad
- Major flow by highway
- Minor flow by railroad
- Minor flow by highway

Coal flow within the Congressional district boundaries is shown in the map.

Water is needed not only to provide cooling for conversion and power processes, but also to rehabilitate stripmined areas. The NAS study points out: "At any distributed site in the desert West, the reestablished vegetation should not be expected to be greater than the original cover, because the native plants have developed through the processes of natural ecological succession. Experience has shown that the process requires from twenty to fifty years or more even when a seed source is close by and the disturbed areas are not extensive. Consequently, the probability for successfully rehabilitating such areas is extremely low."<sup>73</sup> The report suggests that many western areas might have to be classified "national sacrifice areas," since they could be rejuvenated only partially once strip mined.<sup>74</sup>

#### Nuclear Power (2.2-4)

Tremendous power from atomic energy was theorized as early as 1905 when Albert Einstein mathematically demonstrated that the nuclear energy content of a substance depends on its mass ( $E = mc^2$ ). It was not until 1942, when a group of scientists led by Dr. Enrico Fermi built the first atomic reactor at the University of Chicago that the nuclear reaction was harnessed.

Commercial nuclear reactors operating in the U.S. today produce electricity by using the energy of the fission reaction to heat water to generate steam for turning turbines. Fission is an energy conversion process in which neutrons subatomic particles bombard and split the heavy atomic nuclei of elements such as uranium. The neutrons which split uranium atoms must be released at a controlled rate to sustain a chain reaction. The thin rods of uranium fuel within the reactor are surrounded by control rods made of materials which absorb neutrons. Water is circulated through the reactor core to remove and use the generated heat.

Nuclear steam generation is the newest type of electric generating technology. Nuclear power now supplies about eleven percent of all U.S. electricity. As of July, 1980 there are 74 nuclear power plants in the U.S. in operation or start-up testing, with construction permits granted for 85 more. Construction permits are pending for fourteen nuclear power plants.<sup>75</sup>

Some states rely more heavily on nuclear-generated electricity than others. Illinois, New York, Connecticut, Pennsylvania, South Carolina, Virginia, Florida, and Alabama all received substantial portions of their electricity from nuclear plants in 1975.<sup>76</sup>

Nuclear plants are sited close to where their power will be used, instead of near their fuel sources, like coal plants. The main considerations in siting nuclear plants are safety and environmental effects, as well as the availability of cooling water. Because of the transmission costs of electricity, plants are built as close to consumers as the above factors will allow. Sites for related facilities depend on other resource considerations. For example, enrichment plants require large amounts of electricity and uranium mills require a great deal of water and are sited along streams.<sup>77</sup>

Further centralization of nuclear facilities--reactors, reprocessing and fuel fabrication facilities--into nuclear energy "parks" has been suggested as a means of eliminating long transportation hauls of nuclear materials and thus their exposure to hijackers, terrorists, and inadvertent accidents.<sup>78</sup>

Reliance on nuclear fission power plants as a source of United States electricity will be limited by several factors. Two important issues are the availability of uranium and other fuels, and the safe and efficient operation of various reactor types.

The major limiting factor in nuclear power growth is the natural limit of the availability of uranium fuel. According to new estimates by the U.S. Geological Survey, the domestic reserves of uranium that the U.S. now has could supply only fifteen percent of the uranium that the U.S. plans to use between now and 2000. According to U.S.G.S. Frank C. Armstrong, the U.S. will need between 1.6 and two million tons (1,451.5 and 1,814.4 million kg) of uranium ore over the next 25 years, but U.S. production could only supply 315,000 tons (285.8 million kg). Current U.S. uranium reserves total about 600,000 tons (544.3 million kg), with another one million tons (907.2 million kg) in the "undiscovered but probable" category. Another two million tons (1,814.4 million kg) are considered "speculative" and "possible" by the U.S.G.S.<sup>79</sup>

According to Warren Finch, Chief of the U.S.G.S. Branch of Uranium and Thorium Resources, "The uranium found thus far was easy. It was at or near the surface. The new ore for the future will have to be found in deeper horizons and be of lower grade."<sup>80</sup> He points out that no new uranium mining districts have been found in the U.S. in the last eighteen years, but three to five times the uranium found in the last quarter century will have to be located before 2000. Uranium procession and mining operations have used some new technologies such as solution mining to expand the available resource. Atlantic Richfield Company has drilled wells in Texas and pumped alkaline leachants into them to release liquid containing uranium oxide. The liquid is filtered, dried, and shipped to processing plants. However promising this technology, experts in the nuclear industry predict that solution mining will be capable of supplying only 7,000 tons (6.4 million kg) of raw material to the industry in 1985.<sup>81</sup>

An additional limit to the nuclear industry is the nuclear fuel cycle's tremendous demand for materials and energy. Various estimates of the energy required to produce electricity from the atom indicate that it will take from 25 months to thirteen years to "pay back" the costs of energy to build and operate the plant.<sup>82</sup> Other procedures, including the decommissioning of nuclear plants, require additional energy expenditures not included in the conventional analysis of net energy from nuclear-generated electricity. At the end of a nuclear power plant's lifetime (approximately 30 years), the whole installation must be dismantled and buried, since the components are highly radioactive.

The Department of Energy, in its 1976 energy study, National Energy Outlook, predicted that nuclear power generation would supply 26 percent of the nation's electricity, compared to 8.6 percent in 1975, but the continuing problems in the nuclear industry, stemming from resource limits, financial limits, and technological difficulties, may significantly reduce the future supply of power from this source.<sup>83</sup>

Figure 2.2-4 is a diagram of the various steps in the nuclear fuel cycle, not all of which have been activated as of this writing.

There are seven basic steps to the nuclear fuel cycle:

1. Uranium ore is shipped from the mine to a milling facility where it is refined to uranium oxide, or yellowcake. Uranium presents problems similar to those encountered in coal mining; that is, there are conflicts in water and land use and physical dangers to miners in the form of radioactive dust and mine hazards. One kilogram of uranium ore yields the same thermal energy as about 50 kilograms of bituminous coal.<sup>84</sup> New Mexico, Wyoming, and Utah are the major domestic sources of uranium ore. Canada, Australia, South Africa, Zaire and Gabon are major foreign sources. There are now 32 separate facilities in the U.S either operating or planning to produce yellowcake. These mills are capable of processing about 800,000 tons (725.7 million kg) of uranium ore each month, yielding about 1,320 tons (1.2 million kg) of yellowcake monthly.<sup>85</sup>

2. Trucks carry an average of 44,000 pounds (39.9 million kg) of uranium concentrate to a conversion facility, where uranium hexafluoride ( $UF_6$ ) is produced. There are two uranium hexafluoride conversion plants in the U.S. One plant is located in Metropolis, Illinois, and one is Sallisaw, Oklahoma. Between them they can produce about 1,380 metric tons of  $UF_6$  per month.

3. Uranium hexafluoride is shipped to an enrichment plant, which produces two different types of uranium hexafluoride. In one, the preparation of fissionable Uranium-235 is increased; in the other, it is depleted. Lightwater reactors (LWRs), the type now used in the U.S., require uranium fuel that is about three percent U-235 and more than 99 percent U-238, which does not fission easily. The depleted uranium left with between 1.2 percent and 1.4 percent of the originally present U-235, is stored at the enrichment site as a potential fuel for the advanced breeder reactors, which are still in development.

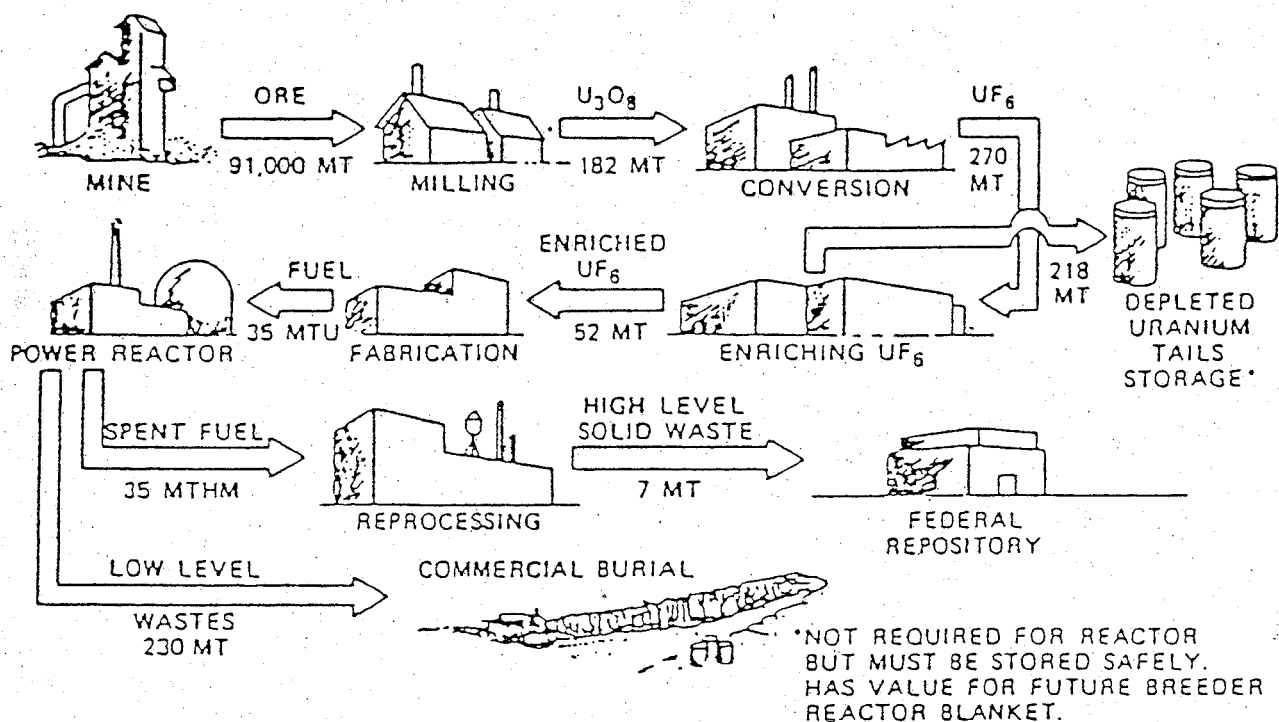
Uranium enrichment facilities, called "gaseous diffusion plants," use about one-third of the energy that goes into producing refined uranium fuel. There are three such facilities, all owned by the federal government, at Portsmouth, Ohio; Oak Ridge, Tennessee; and Paducah, Kentucky. The plant in Kentucky performs only an initial step in light enrichment and ships all material to one of the other two plants. The Tennessee plant now produces the bulk of the low enriched  $UF_6$  used in commercial reactor fuel.<sup>86</sup>

An alternative to the nuclear fuel problem would be to develop the breeder reactor. The breeder reactor can convert U-238 to fissionable plutonium (Pu-239). Plutonium is an extremely long-lived and highly toxic radioactive element with a half-life of 24,000 years. This and its chemical reactivity pose a number of safety as well as technological problems.



Figure 2.2-4 87

DIAGRAM OF NUCLEAR FUEL CYCLE



Average Annual Fuel Materials Requirements for a Typical 1000 Mwe Light Water Reactor

The U.S. is planning a prototype facility for the Liquid Metal Fast Breeder Reactor (LMFBR) near Oak Ridge, Tennessee. However, the original production schedules have fallen far behind and the first test is not expected before the mid-1980s. It will take at least a decade to build and operate the first commercial breeder plants in the U.S., placing the energy contribution from this technology into the next century.

4. Enriched  $UF_6$  is shipped to a fuel assembly fabricator, where it is made into pellets that are inserted into fuel tubes, or fuel rods. The first step to produce fuel pellets is converting the  $UF_6$  to uranium dioxide, or  $UO_2$ . Sometimes this process must be done at a separate facility, but often this work is performed in the same plant or an adjacent one.

There are now seven companies in the U.S. making powdered  $UO_2$  and pressing it into pellets: some also fabricate fuel assemblies. Fabrication facilities are located in Columbia, South Carolina; Windsor, Connecticut; Wilmington, North Carolina; Lynchburg, Virginia; and Richland, Washington. Fabricators usually ship nuclear fuel assemblies by truck to the reactors where they will be used.<sup>88</sup>

5. Nuclear fuel assemblies are gradually spent in the production of heat to make steam for electrical generation. The Uranium-235 and plutonium contained in the fuel assemblies in the core of the nuclear reactor disintegrate to produce high-velocity particles with a great deal of kinetic energy. These energetic particles collide with one another and the structural elements of the core, and so convert much of their kinetic energy into heat. This heat transfers to a fluid coolant that circulates through the reactor core.<sup>89</sup>

Types of fission reactors are designated by the type of coolant they use. In the boiling-water reactor, water is the coolant. When the steam produced by the heat has done its job of turning one or more steam turbines, it is condensed and returns to the reactor core as hot water.

Other types of nuclear power plants use special coolants rather than water. For example, heavy water, an organic liquid, a liquid metal, or a gas such as air, carbon dioxide, or helium may be used as the cooling medium. In these plants, the heat from the coolant is transferred by means of a heat exchanger to a water-steam-turbine-generator system. Waste heat from the plant is recycled to the coolant water.

The nuclear reaction which consumes the fuel is a chain reaction, which requires a large inventory of fuel. However, only a small fraction of the fuel is expended or burned in a day. To produce 1,000 megawatts (MW), a reactor need only fission one kilogram of Uranium-235 a day, or about 800 pounds (362.9 kg) a year.<sup>90</sup>

6. Spent fuel is either stored at the reactor site or shipped to a fuel repository. Two of these repositories are at sites intended for fuel reprocessing facilities, although no fuel reprocessing is now being done.

Three commercial nuclear fuel reprocessing plants have been built in the U.S. These three plants, Nuclear Fuel Services, located in West Valley, New York; General Electric at Morris, Illinois; and Allied General Nuclear Services at Barnwell, South Carolina are not currently in operation.<sup>91</sup>

Spent fuel must be removed from the reactor core at a rate of about one-third of the fuel per year. The spent fuel waste is first stored at the reactor site so that intense, short-lived radioactivity can decay. With few repositories available, wastes are now being stored at temporary facilities and the overflow has become a serious disposal problem.<sup>92</sup>

7. Other wastes contaminated with low-level radiation are transported from the reactor to one of six commercial burial sites. Low-level wastes such as contaminated gloves, radiation suits, and tools, are produced at all stages of nuclear power production and must be buried.

In 1975, all movements of nuclear materials were by trucks on highways except for enriched  $UF_6$  which is transported directly by the government owned-enrichment plants. Despite the higher costs incurred by using this form of transport for long distances, trucks offer numerous advantages over other transport modes. They are relatively inexpensive to purchase, operate on public roads, do not require their own right-of-ways, and they are capable of carrying solid commodities from point to point with greater ease and speed than any other ground transport mode.

The general pattern of nuclear fuel transportation in the U.S. is predominantly from west to east. Uranium yellowcake shipments travel from Colorado, Wyoming, and New Mexico to eastern Oklahoma and Illinois. From here, the uranium hexafluoride moves further east to the three enrichment centers in Paducah, Kentucky, Portsmouth, Ohio; and Oak Ridge, Tennessee. Some of the enriched material returns west to the powder-pellet facility at Oklahoma City or the fabrication plant at Richland, Washington. However, the major part of the enriched uranium flows further east primarily to fuel fabricators in South Carolina and North Carolina. The concentrated, and crucial intermediary steps of the fuel cycle center on the lower mid-Atlantic and Appalachian regions. The major nuclear fuel consuming states are Illinois, New York, Connecticut, Pennsylvania, South Carolina, Virginia, Florida, and Alabama. Fig. 2.2-5 shows total nuclear fuel movements.

This flow pattern is in contrast to all other energy transportation flows which follow the traditional path of east to west. With development of western coal and the eastern movement of Alaskan oil and gas, however, the west to east flow could reverse the traditional pattern.

Relative to other commodities, truck transport of nuclear materials is light. The heaviest recorded flow between two points of the nuclear cycle amounted to little more than an average of one truck per day in 1975. One of the busiest crossroads in nuclear traffic occurs along interstate highway 40 from Nashville to Knoxville, Tennessee. By way of comparison, almost all of the uranium yellowcake transported in 1975 to hexafluoride converters could have been loaded in a single unit (coal) train of 10,000 tons.

When one measures the energy content per truckload, it takes over 3,000 unit (coal) trains to match the energy carried by one unit nuclear train.

#### Hydroelectric Power (2.2-5)

One of the most efficient of generating electricity is by powering turbines and generators with the force of falling water. This conversion of kinetic to electric energy is about 95 percent efficient.

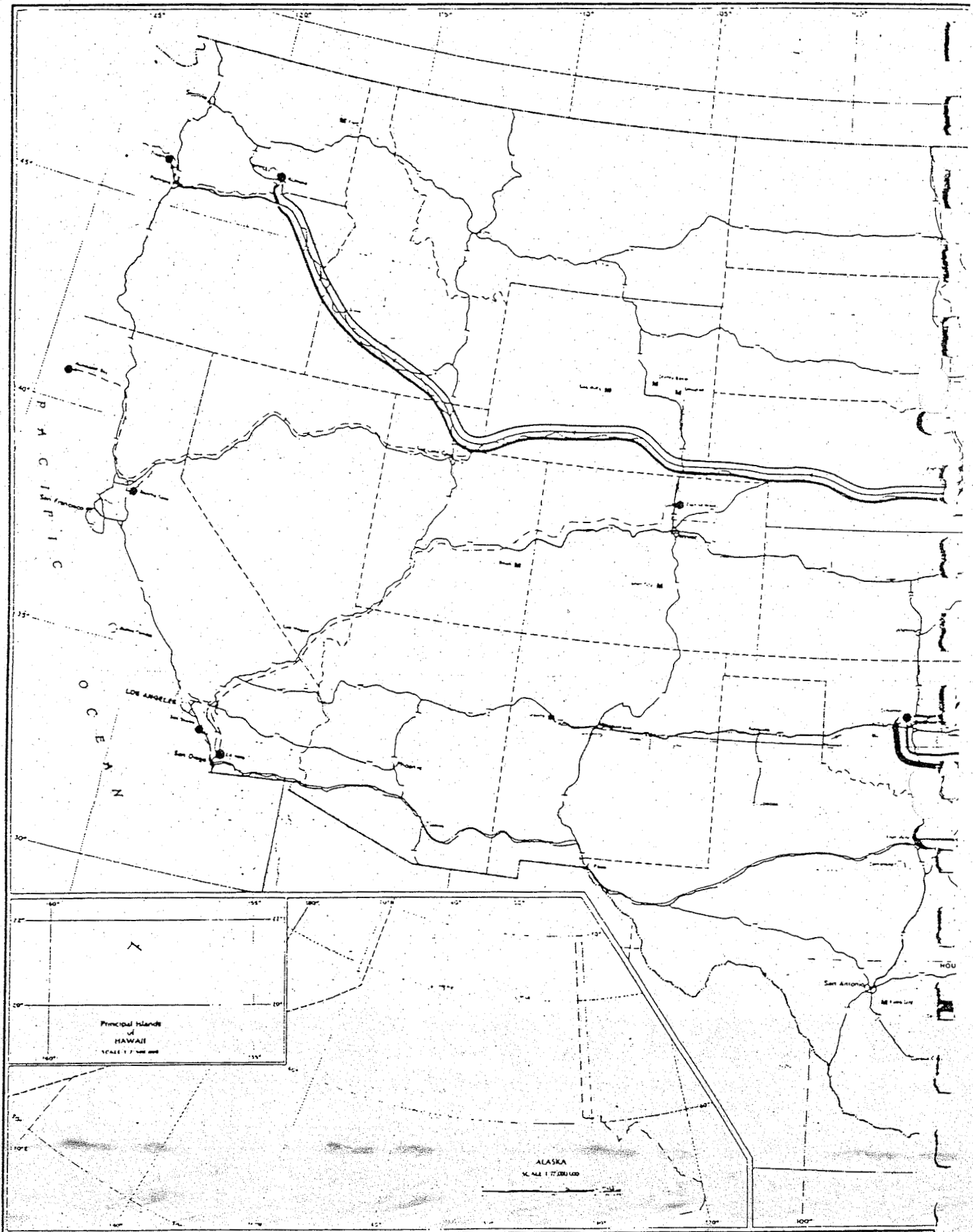
Flowing or dammed water was one of the first power sources tapped to produce electricity. The water wheel, invented for grinding grain and pumping water, was converted to a system to drive electrical generators. Within a month of the opening of the first central electric generating station in 1892, water-wheels on the Fox River in Appleton, Wisconsin began generating the nation's first hydroelectricity.<sup>94</sup>

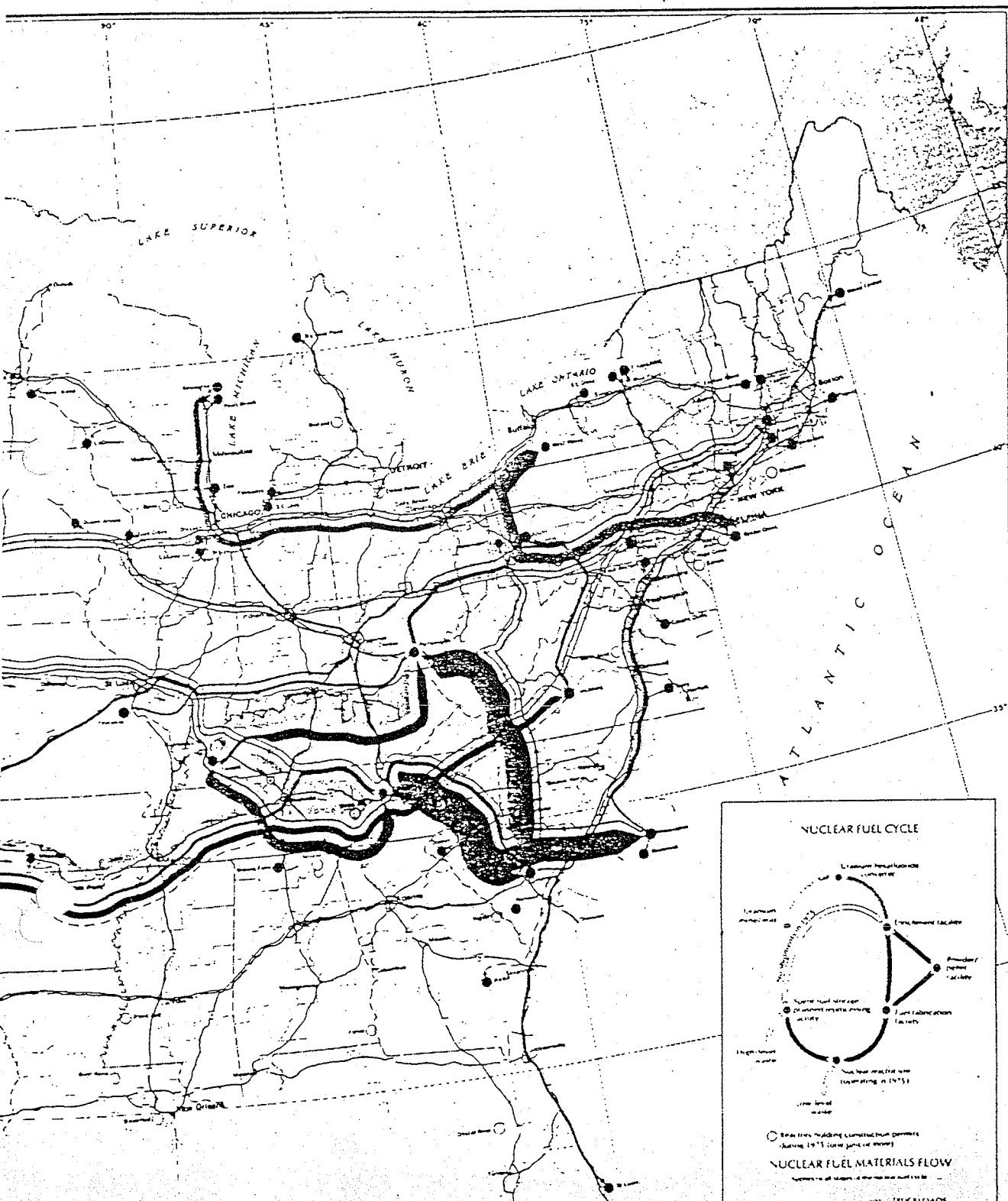
The water wheel proved to be inefficient, and was replaced by modern turbo-generators which could withstand high water pressure. Large dams were built to supply the pressure. Installed conventional hydroelectric capacity in the U.S. tripled between 1921 and 1940, and nearly tripled again from 1940 to 1960, and will have doubled again by the end of 1980.<sup>95</sup>

In 1940, hydroelectric turbines supplied 30 percent of the nation's electricity. By 1971, this had fallen to fifteen percent of installed generating capacity. Hydroelectricity now supplies about twelve percent of U.S. electricity.<sup>96</sup>

Figure 2.2-593

NUCLEAR FUEL MOVEMENTS MAP

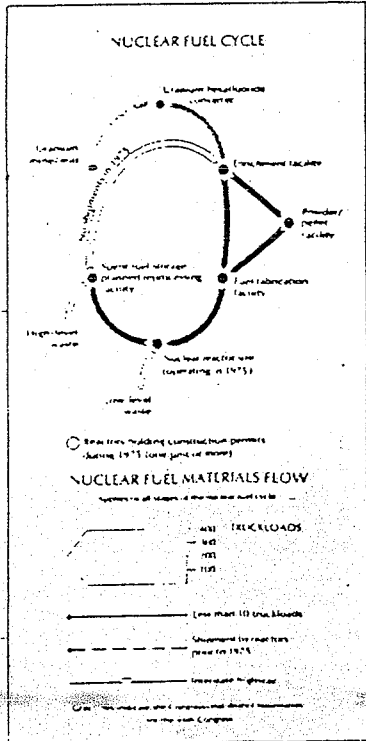




**NUCLEAR FUEL MATERIALS MOVEMENT BY HIGHWAYS (TRUCKLOADS) 1975**

This map shows the distribution of nuclear fuel materials by highway in 1975. It is based on data provided by the U.S. Nuclear Energy Research Administration, the U.S. Department of Energy, and the U.S. Department of Transportation. The map shows the movement of nuclear fuel materials from production facilities to reactors and from reactors to fuel fabrication facilities. The map is based on data provided by the U.S. Nuclear Energy Research Administration, the U.S. Department of Energy, and the U.S. Department of Transportation. The map is based on data provided by the U.S. Nuclear Energy Research Administration, the U.S. Department of Energy, and the U.S. Department of Transportation.

Albers Equal Area Projection  
SCALE 1:7,500,000



The electrical generating facilities in many old dams were retired when replaced by cheaper, centrally generated electricity, and much of the recent increase in hydroelectric capacity is actually in storage facilities at existing large hydroelectric plants. During times of off-peak electrical demand, the water is released to supply energy.

Hydroelectric capacity in the U.S. can be divided between "small" or "low-head" hydro facilities and big facilities. "Small" hydro has been defined by the U.S. Department of Energy as a dam generating less than fifteen megawatts, and "low-head" dams (the head being the distance between the surface of the water behind the dam and the foot of the dam) as being less than sixteen feet high.

In 1973, the U.S. produced 271,634 billion kilowatt-hours (271.6 billion MW) of hydroelectricity, or about 3.4 quads. In 1977, the U.S. used 2.4 quads of hydroelectricity or about four percent of total U.S. energy consumption.<sup>97</sup> The U.S. has a total installed hydro-generating capacity of 63,648 megawatts. According to a report by the Army Corps of Engineers, "Including the expected output of facilities currently under construction, the annual average electricity production from conventional hydropower plants is 287.8 billion kwh, compared to a total U.S. electricity production of about 2,000 billion kwh in 1976."<sup>98</sup>

The state of Washington is the largest producer of hydroelectricity with 71,429,000,000 kwh (71.4 million MW) in 1971, 26.8 percent of the nation's total hydroelectric production. California, the next largest, produces about half that amount, and Oregon about the same as California. New York also has a substantial amount of hydroelectric production.<sup>99</sup>

The potential for expanding hydroelectric generation is limited by the fact that environmental and resource-conservation priorities stand in the way of further damming of the nation's wild and scenic rivers. The most productive sites for hydroelectric dams are already in use today, and federal energy studies do not indicate that increased large-scale hydroelectric power will be a major contributor to the nation's energy future.

In 1977, President Carter asked the U.S. Army Corps of Engineers to study the potential for additional hydropower from existing dams. In a report released in July of that year, the Corps reported that an additional 54.6 megawatts could be achieved by "upgrading and expanding existing hydropower facilities to all existing large and small dams in the U.S." The Corps estimated that the rate of production at the level of development would be an additional 159.3 billion kwh (159.3 million MW) per year.<sup>100</sup>

If this projected capacity were completely developed, the Corps estimates that it "could defer 15.3 percent and 8.65 percent of the projected growth in steam-electric capacity and generation during the period 1975 - 1985." In terms of oil consumption, the Corps estimates that complete development could save the equivalent of 727,000 barrels per day. The Corps' report cautions, however, that such figures represent an "upper bound on the physical potential" of existing dams in the U.S., and "does not include detailed consideration of engineering, economic, financial, or environmental feasibility," competition for water, or institutional and legal barriers.<sup>101</sup>



Hydropower is, in the long run, a relatively inexpensive way to produce electricity, but high initial capital investments are required to construct dams, turbines, generators, and other equipment. The electricity produced by hydro grows cheaper as the capital investment is paid off, with low maintenance costs and zero outlay for fuels.

## Energy Distribution Systems (2.3)

Because electricity moves by wire and cannot be stored in large quantities, it must move directly from the generating plant to the customer, through electrical transmission and distribution systems. Transmission has been defined as electrical movement through power lines of capacity greater than 69 kilovolts (kv), and distribution usually over shorter distances, has been defined as movement through lines of less than 69 kv capacity. "Bulk power supply" moves electricity through lines carrying more than 230 kv.<sup>102</sup>

### Transmission (2.3-1)

Energy from generating plants is fed into the transmission system at full voltage, then transformed at substations into lower voltages for residential, commercial, and industrial uses, usually 110 and 220 volts. Utilities use sophisticated equipment such as switching gear, transformers, and lightning arrestors to handle high voltage electric arcs and power surges.<sup>103</sup>

As of 1978, the electrical transmission system for privately owned utilities in the U.S. consisted of 331,807 structure-miles (533,991.6 km) of transmission lines, including lines of all voltages from 0 to 765 kv.<sup>104</sup> In addition to transmission within the U.S., inter-ties with Canada and Mexico move a great deal of electricity into the U.S. electrical system. Four new interconnections between the U.S. and Canada are expected to be completed by 1984.<sup>105</sup> One of these interconnections between James Bay and New York City will be the highest voltage international transmission line in the world, using 765 kv lines.

Efficiencies in electrical transmission improved along with efficiencies in generation. Between 1900 and 1960, the maximum alternating current voltages increased from less than 50 kv to almost 500 kv. Increased loading of lines incurred increased losses of electricity, but these were offset by greater capacity with the net result that utilities were able to transmit electricity longer distances at lower costs. Line capacity has more than doubled since the 1950s, from 345 to 765 kv.<sup>106</sup>

Table 2.3-1 shows the transmission volt mileages of various kilovolt levels in the United States at ten-year intervals since 1940. It illustrates the increasing use of high voltage wires.<sup>107</sup>

In 1975, the Federal Power Commission reported that it expected the U.S. to add 61,000 miles to the present major supply transmission network by 1984, with two-thirds of this addition at 230 and 345 kv levels. It reported proposals of 1,500 additional miles of the highest operating alternating current transmission, 765 kv, and anticipated another 1,844 miles of direct current line in service by 1984.<sup>108</sup>

Electrical transmission has been concentrated into lines of increasingly higher voltage because of economies of scale similar to those of pipelines. The Congressional Research Service's Report, National Energy Transportation, states "...electricity can be transmitted as effectively 300 miles (482.8 km) over a 765 kv line as it can be transmitted ten miles (16.09 km) over a 138 kilovolt line. A single 765 kv line can carry more than 2,000 megawatts over a long distance; this would require five 345 kv lines."<sup>109</sup>

Overhead transmission is the most economical and efficient method of moving electricity. Because it requires fifteen to twenty acres of land per mile of transmission line, overhead transmission becomes another factor in centralization of transmission. Utilities use higher voltage lines to minimize their use of land.

Table 2.3-1<sup>110</sup>

MILES OF TRANSMISSION IN USE AT 230 KV OR ABOVE  
(THOUSANDS OF MILES)

	<u>230kv</u>	<u>287kv</u>	<u>345kv</u>	<u>500kv</u>	<u>765kv</u>	<u>Total</u>
1940	2.3	.6	--	--	--	2.9
1950	7.4	.8	--	--	--	8.2
1960	18.7	1.0	2.6	.1	--	22.4
1970	40.6	1.0	15.1	7.2	.5	64.6

High voltage lines of up to 230 kv are found in almost every state. Concentrations of 345 kv lines (up to four per route) move large quantities of electricity to population centers in the eastern states, and from Washington down the length of Oregon to California.<sup>111</sup> To further cut transmission costs, the utility industry has inter-tied regions larger than single company franchise areas, and created power pools. These organizations regulate the generation and dispatching of electricity to all pool members so as to achieve the lowest cost for the pool as a whole.<sup>112</sup>

Distribution (2.3-2)

Once the electricity has been transmitted to the local service area, the high voltages must be reduced by line transformers. These transformers and secondary line transformers reduce the voltage to the 120-240 volts used in homes or increase the voltage to 2,400 volts used in industry. This final stage of the electricity delivery process is called the "distribution system". At present, there are over four million pole miles (6,437.3 million km) of lower voltage distribution lines that service residential, commercial and industrial customers.

## Factors Influencing Centralization (2.4)

### Overview (2.4-1)

With the advent of the electrical generating plant, it was logical to locate as close as possible to the prospective customers. The optimum sites for power plants were therefore initially in or near the industrial sector. Proximity to end-use requirements saved on transmission costs and access to water and fuel transportation facilities was already established. Once the prime sites were taken, however, it was necessary to locate electrical power plants in the suburbs, away from the industrial centers.

As the electrical industry expanded, it became a trend for the smaller companies to merge in order to enjoy greater economies of scale. A larger plant could produce more electricity and deliver it further distances at a reduced unit cost. At the same time, technological advances in design, engineering and industrial construction sustained rapid growth in electricity demand and improvements in thermal efficiencies of central station power generation and electric transmission made such economies feasible.<sup>113</sup>

World War I greatly accelerated the trend toward interconnections between utilities because of the dramatic increase in electrical demand. As a matter of national security, electricity supplies had to meet critical war industry demands. The benefits of increased efficiencies due to consolidation were recognized and implemented which solidified the trend toward centralized electricity systems.

Rapid progress in the development of higher maximum voltage transmission lines, larger generating capabilities and improved distribution facilities required greater capital investment and provided another reason for ownership consolidation of the numerous small scale power plants. Private ownership by individuals was impractical and soon gave way to the investor-owned utilities that dominated the market.

The need for larger amounts of capital required different financial and institutional arrangements. Thus, "standard mortgages were replaced by open-ended mortgages, gradually creating an incentive for transfer of investor-owned systems to larger holding companies."<sup>114</sup> These public utility holding companies acquired control over many regional companies by purchasing sufficient stock in each to direct its operation. By 1932, eight holding companies produced 75 percent of the electricity consumed in the U.S. The trend toward consolidation within the electric power industry continued, eventually resulting in a relatively smaller number of producers generating a larger percentage of the nation's electricity.

In order to further expand the availability of electricity, the federal government initiated another method of financing. In 1935, President Roosevelt introduced the Rural Electrification Administration (REA) which provided low-interest loans for cooperatives and non-profit organizations to overcome the high costs of central-station electricity in the rural sector. The Rural Electrification Act of 1936 successfully encouraged the extension of electricity to the country's less populated rural areas. "As of June 30, 1968, 19.4 percent of all the farms in the United States had central-station electric service available."<sup>115</sup>

Over half of the farms were served by the rural electric cooperatives at that time and the remainder were supplied by investor-owned companies, public utility districts and municipal plants.<sup>116</sup>

The electric utility industry continued its trend toward centralization for the next three decades by means of technological advances, improved economies of scale with larger power plants and consistent growth rates for demand. During the 1930s and 1940s, much larger power plants were built as a result of the use of hydrogen-cooled generators. By the early 1950s, higher steam pressures and temperatures became possible due to technological advances, although scientists discovered that lower steam pressures of around 2400 psi were more desirable for the efficiency of the overall operation of a power plant.<sup>117</sup>

When it was not feasible to make a single power plant larger, there were incentives to build additional units upon a previously existing power plant site. Multiple units per site resulted in lower costs of production due to the exclusion of costs of land acquisition, transportation facilities, and licensing obstacles. Thermal efficiencies were also improved but plateaued by the 1960s due to inherent thermodynamic limitations.

In addition to improvements in generating capabilities, progress was made in transmission facilities. As lines were devised to carry higher voltages, the maximum voltage capacity increased from 50 kilovolts in 1900 to current capacities of 765 kv.

In every case, the costs of research and development, production and installation were offset by the ability to produce and distribute electricity at overall lower costs. For example.

Other things equal, the per unit costs of transmitting large amounts of electric energy over significant distances are greatly reduced by utilizing the highest voltage line available. Power transmission lines are generally categorized as "high-voltage", 69 to 300 kilovolts; "extra-high-voltage," (EHV), 300 to 1000 kilovolts; and "ultra-high-voltage (UHV), 1000 kilovolts and above."<sup>118</sup>

As more efficient means of production were developed, the utilities enjoyed continued economies of scale. Electricity was consistently delivered to the consumer at lower marginal costs of power production.

Today the electric utilities in America are divided into investor-owned utilities, municipal utilities, cooperatives, and federal agency utilities. Private, investor-owned utilities produce the majority of the nation's electricity and thus form the base of the electric power industry. By 1920 there were almost 6,500 investor-owned utilities, accounting for 94 percent of the generating market. Today, only 250 privately-owned utilities contribute about 90 percent of our electricity power supply.<sup>119,120</sup>

Municipal and public utilities have also participated in the trend toward centralization. Messing argues that:

...public power systems--which theoretically provide an appropriate mechanism for the design and implementation of decentralized energy systems--have in the past provided an extensive market and an institutional incentive for the development of centralized power. Although they give the appearance of heterogeneity, diversity, and public ownership to the electric utility industry, from the standpoint of system development they have served to support increased centralization through the provision of an extensive distribution and marketing network, and the absence of a competitive interest either in owning and operating generating systems, or in providing integrated energy planning in local planning decisions.<sup>121</sup>

The Bonneville Power Administration established in 1936, is a major broker of power resources rather than a major producer of electric power. The Southwestern Power Administration established in 1944, the Southeastern Power Administration established in 1950, the Alaska Power Administration established in 1956 and the Western Area Power Administration established in 1977 produce hydroelectric power for federal water projects and function as marketing agents. The Tennessee Valley Authority (TVA) established in 1935, is the only federally-owned power corporation. It is the only one of the six federal energy agencies to own and operate thermal electric generating facilities. In 1970, the TVA had become the single largest electric utility in the country, producing five percent of the nation's total generating capacity. Altogether, the six federal agency utilities account for about twelve percent of the total U.S. generating capacity.<sup>122</sup>

#### Utility Regulation (2.4-2)

In exchange for government granting of protected service areas to single utilities, a complex system of federal, state, and local regulation developed. The electric power industry is one of the most highly regulated industries in the country. Rates, plant siting, environmental considerations, pooling, transmission and distribution lines, fuels, utility structure and financing are all regulated in some measure by at least one of a number of regulating bodies.

The initial shift from local and municipal to state control developed as utility service areas spread from limited urban areas. Federal regulation developed because some electricity systems crossed state borders which made them subject to the Commerce Clause of the Constitution. Other electricity systems blocked rivers, thereby triggering federal constitutional authority to regulate the nation's navigable waters.

The Federal Power Commission became the Federal Energy Regulatory Commission (FERC) which is responsible for regulating interstate transmission, interstate rates, and wholesale marketing of electric power. The Economic Regulatory Administration, like FERC, is housed within the Department of Energy and regulates emergency programs and other interstate actions intended to insure the reliability of the bulk power supply system.



Numerous other laws and agencies which have been established to protect the quality of our environment also affect utilities. The National Environmental Policy Act requires submission of an Environmental Impact Statement whenever various activities affect the environment and the Environmental Protection Agency requires utilities to conform to pollution abatement regulations. The federal Public Utility Regulatory Policy Act of 1978 (PURPA), requires state utility regulatory commissions to scrutinize investor-owned utilities' activities in a number of areas. The three objectives of PURPA are to see that utilities: (1) increase electricity conservation; (2) increase the efficiency of electric generating facilities and resources; and (3) set equitable retail rates for electric consumers.

There are six rate possibilities provided by PURPA to establish equitable rate structures. These rates include: (1) cost-of-service (set according to actual costs); (2) the exclusion of block (declining) rates; (3) time-of-day; (4) seasonal; (5) interruptible; and (6) load management techniques. The states are not forced to implement the various rates if they can prove the rates are inappropriate.<sup>123</sup>

The amount of regulatory control the federal government exercises is very controversial. The debate stems from one view which supports maximum centralized control by government regulation versus another view which supports decentralized utility management. Typifying the former viewpoint was the proposed National Electrical Energy Reliability and Conservation Act of 1977. If passed, S. 1991 would have provided:

...a national bulk power system consisting of power generating facilities and a system of very-high-voltage transmission lines owned and operated by a federal corporation, the National Power Grid Corporation. The National Power Grid Corporation would also establish one federal regional bulk power supply corporation in each of the nation's power supply regions, to blanket the country. The regional corporations would have authority to acquire and operate transmission (but not generating) facilities. The national corporation would take over all federal electric power generating and transmission facilities ...except for the Tennessee Valley Authority which would be able, if it wished, to transfer federal transmission facilities to the regional corporations.<sup>124</sup>

The probability of legislation such as S. 1991 passing is unknown. Considering the uncertainties inherent in the electricity business, it is difficult to predict the course regulation of the utility industry will follow.

#### Utility Rates (2.4-3)

The price of electricity is set by "rate-or-return" or "rate-base" regulations, which are established for the most part by state public utility commissions. The rate base is computed by combining the value of the utility's depreciated plant and equipment, and an allowance for the cost of capital. The prices will theoretically provide a predetermined fair rate of return on the rate base, after allowances for operating and maintenance costs, depreciation and taxes have been made.

Originally, the more electricity customers used, the less it cost the utility to produce electricity per unit. Thus a "sliding scale rate" or "block rate" evolved that accounted for an automatic rate decrease as a customer's electricity consumption increased. After nearly a century of stable rates using the above guidelines, the shock of the Arab oil embargo and resultant quadrupling of oil prices in 1973-74 caused an eventual reversal in the electric industry's rate structure.

Additional factors contributing to this reversal in declining real rates for electricity are the high inflation rates of the last decade, strict environmental requirements, increases in other fuel prices, high maintenance and operating costs, rising costs of capital and the peaking of most economies of scale. Phillip Hill predicted in 1979 that the costs of electrical power generation will increase by a factor of four or five between 1970 and 1985.<sup>125</sup>

## Centralized Alternatives: Synthetic Fuels (2.5)

### Overview (2.5-1)

Easily extractable sources of relatively clean energy are rapidly dwindling worldwide and becoming increasingly expensive. Their scarcity threatens U.S. national security. Development of new energy resources has become both an urgent national priority and an increasingly competitive commercial venture.

One promising source of new energy is the manufacture of synthetic fuels (synfuels) from coal and oil shale. Synthetic fuels are obtained by converting a carbonaceous material to another form. Synfuels include low-, medium-, and high-Btu gas, liquid fuels such as fuel oil, diesel, gasoline, methanol, and clean solid fuels.

Since the resource base for synfuels is coal and oil shale, it is important to quantify this resource base. With coal, quality is also important. Coal quality and heat content vary greatly. The fraction of carbon in the coal increases and the moisture content decreases from lignite to anthracite.<sup>126</sup> The U.S. coal fields, excluding Alaska, and types of coal found in these fields are shown in Figure 2.5-1.

Regional distribution of the demonstrated coal reserves is shown on Table 2.5-1. This reserve refers only to identified resources suitable for mining by present methods, where 50 percent of the reserve is recoverable. Almost half of the nation's coal is found in the Northern Great Plains and the Rocky Mountain region where more than 40 percent of the coal can be surface mined. Surface or strip mining can be done more economically and with a much higher proportion of the coal recovered. It is estimated that the nation's coal reserves are sufficient to satisfy the U.S. needs for 200 years at current rates of consumption.<sup>127, 128</sup>

Oil shale is sedimentary rock containing organic matter which when heated to its pyrolysis temperature yields "kerogen." The spent residue, or tailings, are composed mainly of inorganic matter. Shale with about seven percent by weight of organic matter yields approximately ten gallons of oil per ton (.04 liters/kg) of shale. High grade oil shale is considered to be shale with an organic content greater than fourteen percent that yields 25 gallons (.1 liters/kg) or more of oil per ton of shale and is found in seams at least ten feet thick (3 m). In general, oil shale deposits tend to be significantly thicker than coal seams and shale is considerably harder than coal.<sup>129, 130, 131</sup>

Significant quantities of lower grade oil shale are found in many areas of the United States, especially in the same region as the coal reserves. However, the greatest potential for commercial production rests with high grade oil shale located in the areas of Colorado, Utah and Wyoming in what is called the Green River Formation. (See Figure 2.5-2). The identified high grade shales with yields in excess of 25 gallons per ton (.1 liters/kg) have an oil equivalence of approximately 570 to 620 billion barrels. The most productive and accessible zones are estimated to yield about half of this amount.

Figure 2.5-1<sup>132</sup>

COAL FIELDS OF THE CONTERMINOUS UNITED STATES

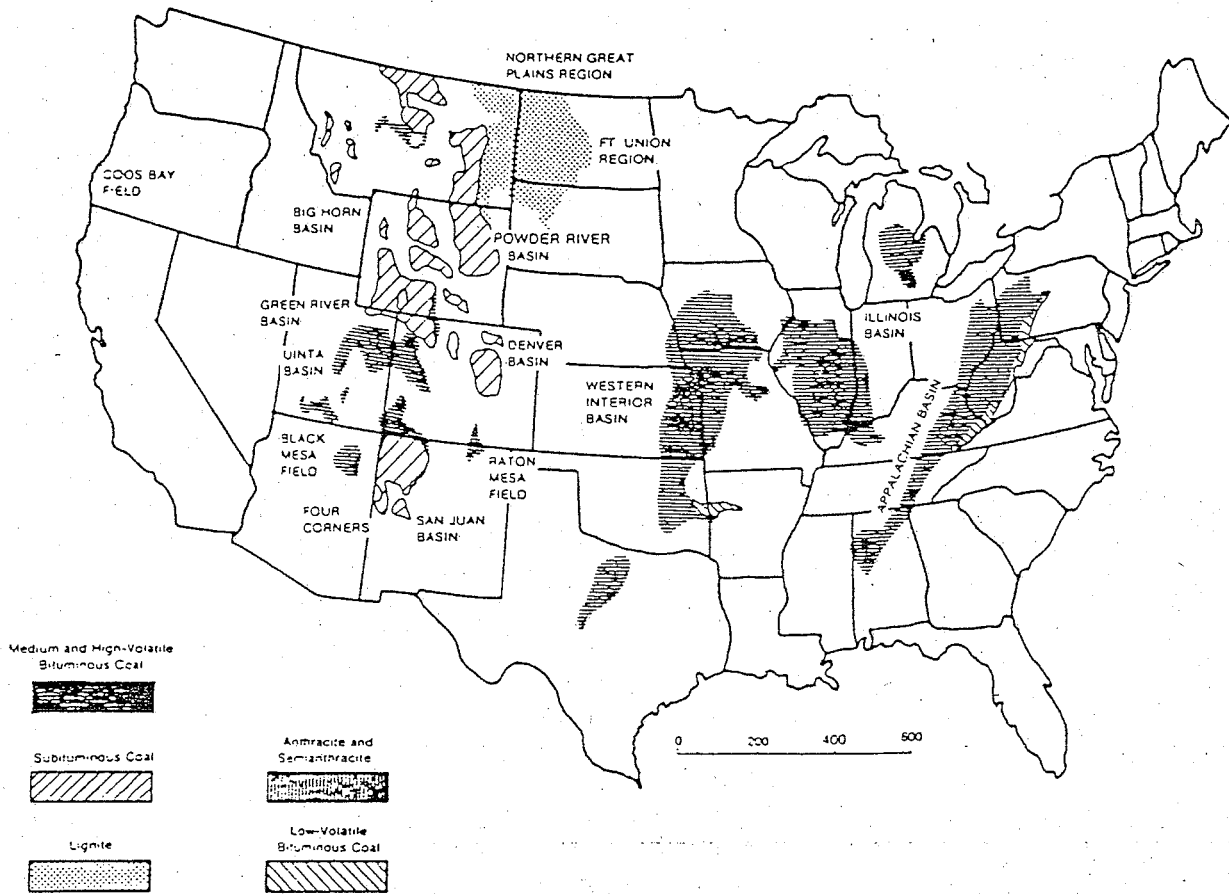


Table 2.5-1<sup>133</sup>

DEMONSTRATED U.S. COAL RESERVES BY REGION AND METHOD OF MINING 10<sup>9</sup> TONS (9.1 x 10<sup>8</sup> kg)

<u>Region</u>	<u>Underground</u>	<u>Surface</u>	<u>Total</u>
Northern Great Plains and Rocky Mountains	113 (51.3)	86 (39)	199 (90.3)
Appalachian Basin	97 (44)	16 (7.3)	113 (51.3)
Illinois Basin	71 (32.2)	18 (8.2)	89 (40.4)
Other	16 (7.3)	17 (7.7)	33 (15)
<b>TOTAL</b>	<b>297 (134.7)</b>	<b>137 (62.1)</b>	<b>434 (196.9)</b>

### Synthetic Fuels from Coal (2.5-2)

Coal is a flexible primary fuel which can be used in its solid form to fuel a conventional boiler, a fluidized bed, or a magnetohydrodynamic facility. Alternately, it can be converted to liquid or gaseous synthetic fuels and used in conventional systems, or in advanced systems specifically designed to match synthetic fuel properties.

Table 2.5-2 lists the various technology options for converting coal to synthetic fuels. Also included are estimated dates for commercial availabilities along with estimated costs in 1980 dollars. It is significant that coal gasification is the initial step in producing several of the listed synthetic fuels. The gas produced from coal may be burned directly to generate process heat or electricity or it may be further processed to produce synthetic natural gas (SNG) or methanol. SNG and methanol can also be used to produce process heat and electricity and, in the case of methanol, can be used in transportation.<sup>134, 135</sup>

### Low-and Medium-Btu Coal Gasification (2.5-3)

Coal can be gasified to produce either a low- or a medium-Btu gas. Low-Btu gas is produced by using air to supply oxygen to a gasifier. It has a heating value of 100 to 250 Btu per standard cubic foot (scf) (320-800 Btu per standard cubic meter). Low-Btu gas can be burned directly to produce process heat or electricity. It is not used, however, as a feedstock for SNG or methanol production. Medium-Btu gas is produced by supplying pure oxygen to the gasifier. It has a heating value of 250 to 450 Btu per scf (800-1,440 Btu per standard cubic meter). Medium-Btu gas has the potential for further processing into SNG or methanol. Figure 2.5-3 illustrates conversion of coal and low- and medium-Btu gas.

The production processes for both low- and medium-Btu gas are similar and, therefore, only the medium-Btu gas process will be discussed. It should be noted that several of the principal coal gasification technologies can be used for either low- or medium-Btu gas production including Lurgi, Koppers-Totzek, and Texaco systems.

Many processes for producing medium-Btu gas from coal have been investigated. In general, they start with the partial oxidation of coal in the presence of steam and oxygen. The gas produced contains combustible components including carbon monoxide, hydrogen, and methane, as well as noncombustible gases such as carbon dioxide and sulfur compounds.<sup>136, 137, 138</sup>

Before it can be used, the gas must be cleaned to remove impurities such as hydrogen sulfide and carbon disulfide. Depending on the particular process, carbon dioxide content may also be reduced. If medium-Btu gas is to be used for SNG or methanol production, it must also undergo shift conversion to increase the hydrogen concentration of the gas. The gasifier produces solid and liquid wastes which require disposal.<sup>139</sup>

Figure 2.5-2<sup>140</sup>

OIL SHALE AREAS OF THE GREEN RIVER FORMATION IN COLORADO, UTAH, AND WYOMING

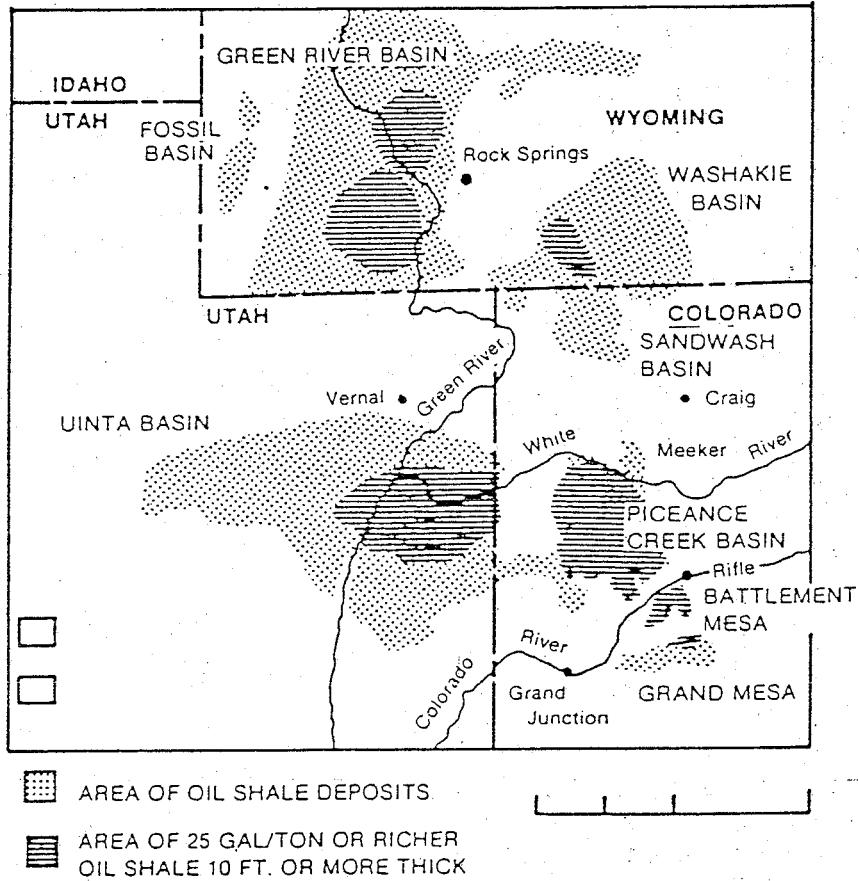


Table 2.5-2<sup>141</sup>

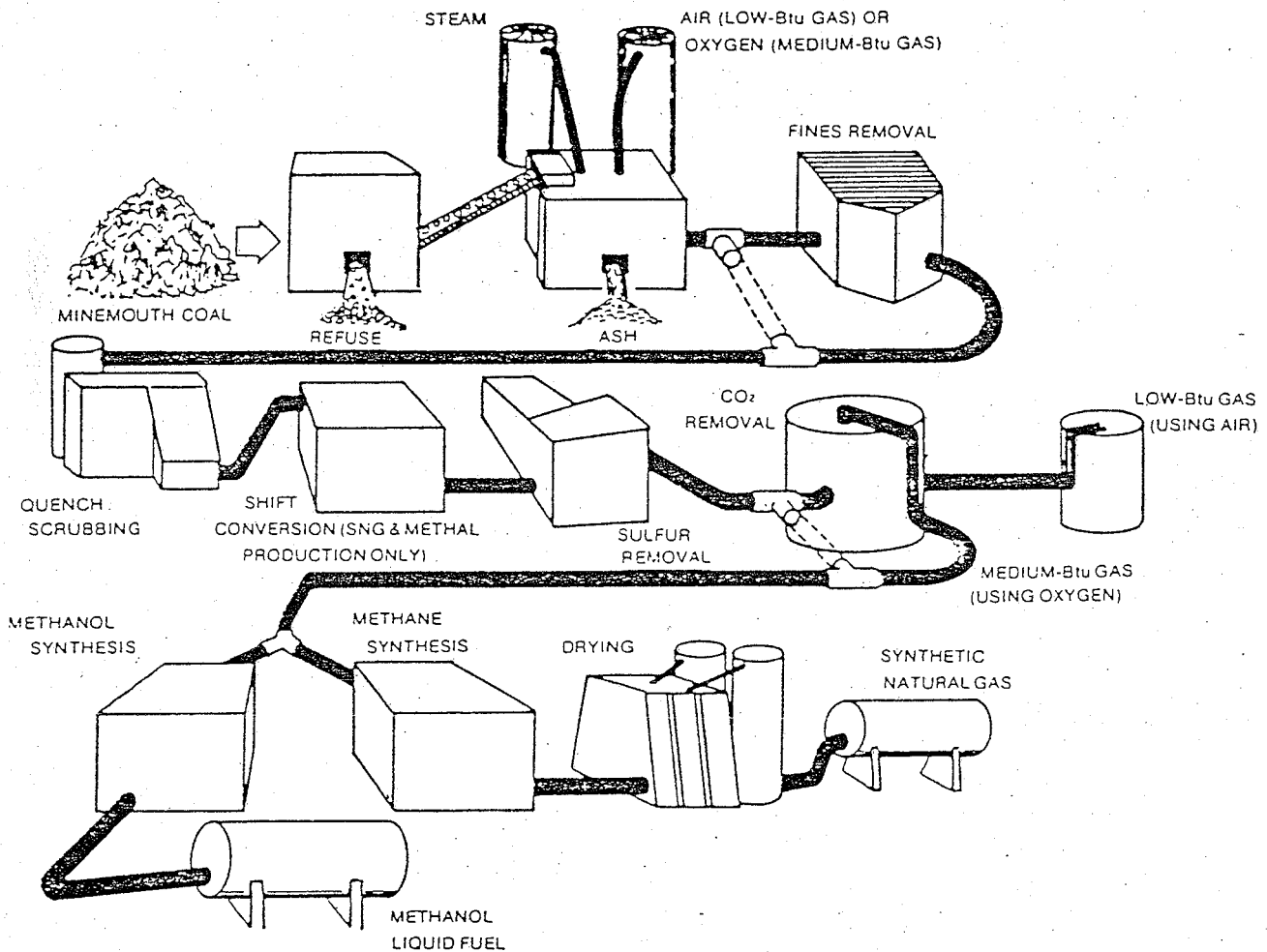
SYNTHETIC FUELS FROM COAL

<u>Technology</u>	<u>Commercially Available</u>	<u>Estimated Cost \$/Million Btu (1980)</u>
Low-, Medium-Btu Gas	1985	4.40 - 6.60
Synthetic Natural Gas	1985	5.50 - 8.80
Methanol From Coal	1986	6.92 - 7.90
Synthetic Oil	1990	5.50 - 7.70



Figure 2.5-3142

COAL GASIFICATION



Proposed or planned coal gasification products in the U.S. include a variety of first and second generation medium-Btu gas processes. First generation processes are in commercial operation in various parts of the world, but not in the U.S. Second generation processes are being developed to improve efficiency and operation flexibility. A selected list of coal gasification processes including those receiving the most attention in the United States is provided in Table 2.5-3.

Commercial suppliers currently exist for the first generation gasifiers such as the Lurgi and Kopper-Totzek. However, commercial suppliers do not exist for second generation systems such as the Texaco process and the necessary technology is still evolving.

Recent estimates for medium-Btu coal gasification range from \$4 to \$6 per million Btu in 1979 dollars. These costs compare to costs of over \$5 per million Btu for #2 diesel fuel. However, the coal gasification cost estimates are based on mine mouth production and do not include transportation costs.<sup>143</sup>

In summary, medium-Btu coal gasification processes are commercially available at reasonable costs. The technology has been commercially demonstrated abroad. The applicability of this experience to the U.S. is uncertain because of differences in economic conditions and environmental regulations. It is also significant that economies of scale are important with medium-Btu gas production. Economies of scale dictate that commercial facilities be relatively large, or equivalent to 500 MW power generation stations. On the other hand, low-Btu gas production is not especially dependent on economies of scale.<sup>144, 145</sup>

#### Coal-Derived Synthetic Natural Gas (2.5-4)

Synthetic natural gas (SNG) is a potential substitute for natural gas and may be used in conventional systems. SNG is a methane-rich, high-Btu gas which has had many of the impurities removed. Its heating value is approximately 1000 Btu per standard cubic foot (3,200 Btu per standard cubic meter). It can be produced from coal, agricultural and lumber residues, municipal solid waste and many other organic materials. The principal method of producing SNG is from the gasification of coal. Gasification and processing can occur at the mine mouth where the SNG can be introduced into the natural gas pipeline system.

There are several major steps in the process for producing SNG from coal. The coal is first gasified to produce medium-Btu gas. The medium-Btu gas must then undergo a shift-conversion process to increase its hydrogen concentration in order to achieve the appropriate hydrogen-carbon ratio for producing methane ( $\text{CH}_4$ ), the primary constituent of SNG. In the final methanation step, the gas is reacted catalytically to form methane from carbon monoxide and hydrogen. After drying, the resulting high-Btu SNG is ready for on-site use or for transmission by pipeline. Pilot demonstrations of catalytic methanation to obtain SNG from medium-Btu gas from coal have been performed in Scotland, South Africa, and Austria.

The Department of Energy (DOE) notes that all of the individual process units required for a SNG-from-coal production facility using first generation gasifiers have operated commercially at numerous plants for purposes of producing SNG from feedstocks other than coal. There is, however, some technical risk in integrating coal gasification and SNG production components into a working commercial scale system.

Large SNG plants previously proposed in the U.S., for example, the El Paso, Wesco and Mercer projects, have been based on first generation Lurgi coal gasification processes. The Mercer County, North Dakota, project may be the nation's first SNG commercial demonstration plant. It would produce 125 million cubic feet of SNG daily.<sup>147</sup>

Suppliers exist for the technology to produce SNG from medium-Btu gas. These include the Institute for Gas Technology, Girdler and Conoco companies.<sup>148</sup>

Table 2.5-3<sup>146</sup>

SELECTED MEDIUM-BTU COAL GASIFICATION PROCESSES

<u>Process</u>	<u>Description</u>	<u>Status</u>	<u>Examples of Proposed Uses In the United States</u>
<u>First Generation</u>			
Lurgi	Fixed bed process operating at 350-450 psi pressure which favors the formation of methane in the gasifier and reduces product transmissions costs (gas is already pressurized). Disadvantages include the production of liquid hydrocarbon by-products that must be separated and difficulty in handling U.S. eastern bituminous coal.	Approximately 20 plants in commercial operation outside U.S., the largest being the SASOL 1 plant in South Africa.	Mercer Co., N.D., planned SNG facility, 15,000 tpd, 1983 start date.
Koppers-Totzek	Entrained flow gasifier operating at atmospheric pressure. Does not generate hydrocarbon by-products.	Sixteen plants in commercial operation outside U.S. primarily for ammonia production; also used in a small-scale methanol-from coal plant in South Africa.	W.R. Grace & Co., for a proposed methanol-from coal facility in Colorado, 10,000 tpd, feasibility study planned for near future.
Winkler	Low-pressure fluidized bed process.	Existing commercial installations include seven plants in Germany.	None identified.
<u>Second Generation</u>			
Stagging-Lurgi	Adaption of the first generation Lurgi process improved to include greater coal throughput and recycling of hydrocarbon by-products.	Pilot plant operated in Westfield, Scotland.	None identified.
Texaco	Pressurized entrained flow gasifier. Generates no hydrocarbon by-products.	A 150 tpd unit operating in West Germany for over a year.	Southern California Edison for a proposed demonstration integrated coal gasification combined cycle power plant in Southern California, 1000 tpd, operation planned for 1983.  DOE/W.R. Grace & Co. for methanol production, in Kentucky, 29,000 tpd, in initial design phase with operation possible by 1966.
U-Gas	Pressurized fluidized bed design.	A 24 tpd pilot plant operated in Chicago by the Inst. of Gas Technology.	DOE/Memphis Light, Gas & Water for industrial fuel use in Memphis, 316 tpd planned for mid-1980s.

Various factors such as inflation and construction lead times affect the estimated cost of future coal gasification plants. Recent estimates project a cost for SNG between \$5 and \$8 per million Btu in 1979 dollars. The current cost of Canadian natural gas is \$4.65 per million Btu. The price of natural gas will continue to increase to approximately \$6 per million Btu. DOE projections for SNG conclude that SNG will be marginally competitive with natural gas under an assumed high natural gas price. Arthur Seler, Jr., Chairman of American Natural Resources Company which leads the consortium building the Mercer County Project, forecast a delivered price from that plant of approximately \$7.25 per million Btu in 1983. He believes this will prove competitive as the costs of other energy sources escalate.<sup>149, 150, 151, 152</sup>

The lack of commercial demonstration, variation and uncertainty in cost estimates for SNG from coal gas and uncertainty about future costs of competing fuels cause a corresponding uncertainty in the commercial availability of SNG.

Comparing the estimated cost of SNG with the rising prices of petroleum products suggests that coal-derived SNG could be used in certain conventional applications, such as power plants, at a reasonable cost. Overall, however, it appears that a commercial demonstration may be needed to evaluate the economic feasibility of SNG production. The potential problems in integrating the medium-Btu gasification and methanation processes into a commercial plant and the possible impacts on reliability and other performance characteristics must be defined. A commercial demonstration would help to reduce the uncertainty of producing SNG from coal and may be a necessary step to establish SNG from coal as a viable energy alternative. Finally, as with medium-Btu gasification, SNG facilities will be subject to economies of scale which dictate that facilities be relatively large and centralized.<sup>153</sup>

#### Methanol from Coal (2.5-5)

Methanol, a liquid fuel derived from coal and other organic materials such as wood and petroleum, could be used as a fuel in conventional utility and industrial systems as well as in the transportation sector. Methanol ( $\text{CH}_3\text{OH}$ ), like SNG, can be synthesized by catalytically reacting medium-Btu gas produced by any coal gasification process which produces  $\text{CO}/\text{H}_2$  mixtures.

The synthesizing of methanol from medium-Btu gas is a well proven technology. At least two companies (Imperial Chemical Industries and Lurgi) offer proprietary processes with guarantees backed by multiple commercial-scale plant operating experience.

A small subcommercial-scale plant for the production of methanol from coal-based medium-Btu gas using the Koppers-Totzek gasification process and the Imperial Chemical Industries methanol process has been operating at the Modderfontein, South Africa plant site for over two years.<sup>154</sup>

No commercial-size methanol-from-coal plants currently exist. Based on the size of a number of proposed projects, however, it is reasonable to expect that a commercial-size plant would probably use at least 5,000 tons (4.5 million kg) of coal per day. Methanol production, however, is in commercial operation using feedstocks such as natural gas and naphtha. The use of coal creates additional technical requirements, such as a need for continuous and reliable high-efficiency gas clean-up to avoid poisoning the methanol synthesis catalyst.<sup>155, 156</sup>

Several commercial projects to produce methanol from coal are now being pursued in the U.S. which could lead to commercial demonstration by 1986. This time frame requires that commitments to construct must begin soon since the permitting process and construction will require at least five years. Wentworth Brothers, Inc. have completed the preliminary engineering and economic evaluations for three potential projects; they selected the Texaco process for coal gasification.

W.R. Grace and Company plans to do a feasibility study for a plant in northwestern Colorado for producing 5,000 tons (4.5 million kg) of methanol per day from coal. The study is expected to take six months and a decision to proceed with the project is expected within a year. Grace plans to use the Kopper-Totzek gasifiers. As also noted in Table 2.5-3, Grace is beginning design analysis for a methanol-from-coal plant, using Texaco gasifiers, where the methanol would then be converted to gasoline. Two other major coal-to-methanol projects are under consideration in the U.S. by Conoco and Texas Eastern. They plan to use the Lurgi gasifier.

Methanol from coal is on the verge of being an economically competitive alternative to coal for power production or as a transportation fuel. However, cost estimates will continue to be subject to uncertainties until more experience is gained.

The commercial availability of coal-derived methanol is uncertain for reasons similar to those for coal-derived SNG. The demonstration of an integrated system is important to establish the technology for gas clean-up, to avoid methanol-synthesis catalyst poisoning, to determine operating requirements, and to study process economics. As with SNG production, methanol production from coal is subject to economies of scale.<sup>157</sup>

#### Synthetic Oil from Coal (2.5-6)

Potentially, several coal-hydroliquefaction processes could be used to produce synthetic oil for conventional applications. In hydroliquefaction, coal is dissolved in an appropriate solvent, then reacted with hydrogen to produce liquid fuel oils. Synthetic oil would require refining in a process similar to that for crude oil. The resulting synthetic fuels could substitute for residual fuel oil or distillate fuel in conventional systems.<sup>158, 159</sup>

Although no plants are now in operation, Germany used the Bergius process for catalytic hydrogenation of coal to make approximately 90 percent of its aviation gasoline in World War II. All modern hydroliquefaction processes are descendants of this process.

The DOE has noted that the H-Coal, Donor Solvent and Solvent Refined Coal (SRC) processes have received significant attention in the U.S. A small five-ton-per-day SRC plant has been operating since 1975; a single module of a commercial-scale plant for each of the SRC processes is in the design phase; a 600-ton-per-day H-Coal plant is under construction; and a 250-ton-per-day Exxon Donor Solvent plant is under construction. Some of these processes could be commercially available by 1990. Currently, however, there are no suppliers in existence to commercially produce synthetic oil from coal. Estimated production costs for synthetic oil are in the range of \$5 to \$7 per million Btu.<sup>160</sup>

There are significant technical differences between synthetic oil production and the gasification process which lead to questions regarding the long-term desirability of developing the liquefaction technologies. Since dried coal is required for the hydroliquefaction processes, use of western coals with higher moisture content may severely reduce the thermal efficiency. Further, the coal liquefaction process does not function well with western coals due to their high oxygen content, high alkalinity and low sulfur levels, and because the high oxygen content results in massive consumption of process gas. The high alkalinity interferes with catalytic reactions, and the low sulfur levels inhibit the dissolution of the coal in the solvent. These suggest that the cost of liquefying many western coals would likely be higher than for eastern coals.<sup>161</sup>

#### Synthetic Fuels from Oil Shale (2.5-7)

Unlike coal which can be readily used in its solid form or converted to several synthetic fuels, synthetic fuels from oil shale will consist primarily of synthetic crude oil. While it is technically feasible to gasify shale oil, the economics and usefulness of such action are not justified. On the other hand, the attractiveness of oil shale development is that the end product, syncrude, is readily adaptable to the existing petroleum infrastructure from refining to the use in utility, industrial and transportation sectors.<sup>162</sup>

Figure 2.5-4 is a block diagram for oil shale development. the conversion of oil shale to finished fuels or other products such as chemical feedstocks requires a series of processing steps. Numerous specific processes can be generically grouped as follows:

1. True in-situ (TIS) processes in which the oil shale is left underground and is heated by injecting hot fluids;
2. Modified in-situ (MIS) processes in which a portion of the shale deposit is mined and the rest is fractured with explosives to create a highly permeable zone through which hot fluids can be circulated;
3. Above Ground Retorting (AGR) processes in which the shale is mined, crushed, and heated in vessels near the mine site.<sup>163</sup>



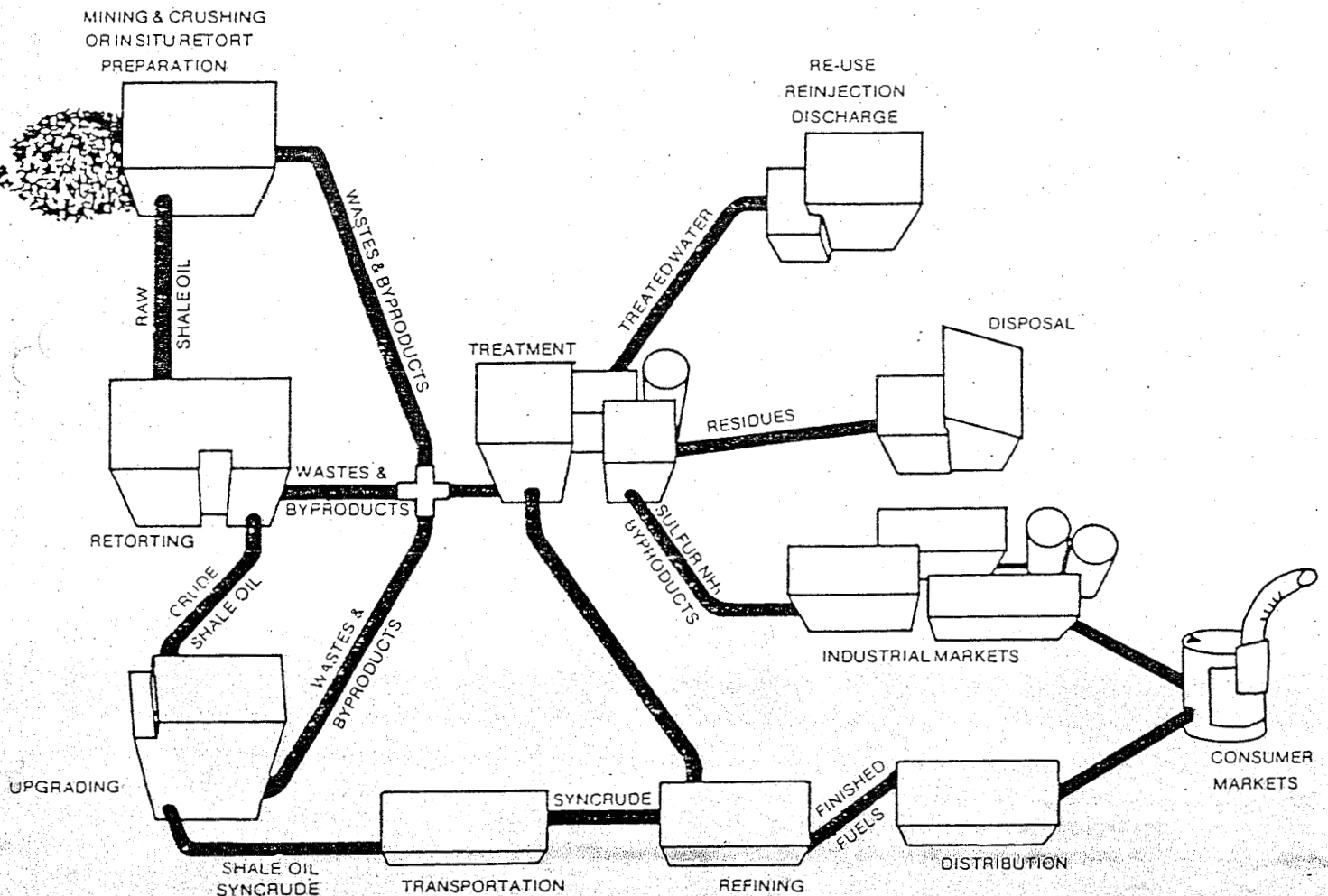
### True In-Situ Processing (TIS) (2.5-8)

Numerous types of TIS processes have been proposed and differences between the processes relate to varying methods for preparing and heating the oil shale deposit. All processes use a system of injection and production wells drilled according to a prescribed pattern. All processes can be generally described by the following steps:

1. Dewatering, if the deposit occurs in a ground water area;
2. Fracturing or rubbing, if the deposit is not already permeable to fluid flow;
3. Injection of a hot fluid or ignition of a portion of the bed to provide heat for pyrolysis; and
4. Recovery of the oil and gases through production wells.

Figure 2.5-4<sup>164</sup>

### OIL SHALE UTILIZATION



In all cases, the permeability of the shale to hot fluids is a critical variable, and that permeability is primarily responsible for the low oil recoveries often associated with TIS processing. That is, large impermeable blocks of shale in the fractured formation cannot be fully retorted in a reasonable length of time, or in some instances irregular fractures can cause the heat carrier to bypass large sections of the deposit.<sup>165, 166</sup>

Research regarding TIS processes is still required. There are currently no commercial-scale plants operating, although the DOE and Geokinetics plan to develop a commercial-scale operation with a production capacity of 2,000 barrels per day by 1982.<sup>167, 168</sup>

#### Modified In-Situ Processing (MIS) (2.5-9)

In the MIS process, some shale is mined from the deposit and then explosives are detonated in the remaining deposit to increase the permeability of the oil shale. This procedure creates a chimney-shaped underground retort filled with broken shale. Access tunnels are sealed and an injection hole is drilled from the surface to the top of the fractured shale. The shale is ignited at the top by injecting air and burning fuel gas, and heat from the combustion of the top layers is carried downward in the gas stream. The bottom of the oil shale is pyrolyzed and oil vapors are swept down the retort to a sump from which they are pumped to the surface. The burning zone moves down the retort fueled by residual carbon in the retorted layers. When the zone reaches the bottom of the retort, the flow of air is stopped and combustion stops.

Occidental Oil Shale, Inc., a subsidiary of Occidental Petroleum Company, has demonstrated the MIS process on a nearly commercial scale. Numerous other companies are also conducting research and development programs with MIS. If present plans are followed, Occidental's technology could be used to produce 57,000 barrels per day by 1985.<sup>169, 170</sup>

The MIS processes are more advanced than TIS methods. The principal advantages of MIS are that large deposits can be retorted, oil recovery ratios are high, and relatively few surface facilities are required. However, some mining and disposal of solid wastes on the surface are required and the oil recovery per unit of ore processed is low relative to above ground retorting methods. In addition, the burned-out MIS retorts have the potential for ground water pollution.<sup>171, 172</sup>

#### Above Ground Retorting (AGR) (2.5-10)

Above Ground Retorting differs from the in-situ processes in that all the shale feedstock is mined. The principal advantage of AGR is the oil recovery efficiency.

Above Ground Retorts are grouped into four classes:

1. Class 1: Heat is transferred by conduction through the retort wall. The Fischer assay retort is in this class and is used to estimate potential shale oil yields. Its oil yield is the standard against which the retorting efficiencies of all other retorts are compared. Because conduction heating is very slow, no modern industrial retorts are in Class 1.

2. Class 2: Heat is transferred by flowing gases generated within the retort by combustion of carbonaceous retorted shale and pyrolysis gases. Retorts in this class are directly heated and produce a spent shale low in residual carbon and low-Btu retort gas. Their thermal efficiencies are relatively high; however, recovery efficiencies are relatively low (about 80-90 percent of Fischer assay).
3. Class 3: Heat is transferred by gases that are heated outside of the retort vessel. These retorts produce a carbonaceous spent shale and a high-Btu gas. Thermal efficiencies are relatively low, but oil recovery efficiencies are high (90-100 percent of Fischer assay).
4. Class 4: Heat is transferred by mixing hot solid particles with oil shale. These retorts achieve high oil yields similar to Class 3 retorts and produce a high Btu gas. The spent shale may or may not contain carbon and thermal efficiencies vary depending on whether the spent shale is used as the heat carrier.

Specific retort designs are under development for each class.<sup>173, 173</sup>

Each of the various oil shale processing options, TIS, MIS and AGR, has its particular advantages and disadvantages. The greatest advantage of TIS processing is that mining is not required and spent shale is not produced on the surface. The technical, economic, and environmental problems associated with AGR waste disposal, and thereby avoided. MIS does involve mining and aboveground waste disposal, although to a lesser extent than with AGR. However, the MIS waste is either overburden or raw oil shale. Both materials are found naturally exposed on the surfaces of deeper canyons in oil shale basins. Although raw shale has low concentrations of the soluble salts, it does contain soluble organic materials that could be leached from the disposal piles. It should be noted that the presence of spent shale underground has the potential to cause environmental problems because soluble salts could be leached by ground water.<sup>175, 176</sup> Therefore, environmental controls will also be needed for TIS and MIS processes.

The advantage of AGR is that the conditions within retorts can be controlled to achieve very high oil recovery rates. Retorting efficiencies for MIS are lower, and much lower for TIS, because of the difficulty in obtaining a uniform distribution of broken shale. AGR processing maintain a minimum retorting efficiency of 80 percent, MIS processing is less than 60 percent efficient, and TIS is two to four percent efficient.

It is expected that yields from MIS retorts could be increased, but it is doubtful that recoveries can reach those of carefully controlled AGR. On the other hand, the present low efficiencies of MIS operations are partially compensated for by their ability to convert very large sections of an oil shale deposit, by the ability to process shale of a lower quality than would be practical for AGR, and by their lower cost of preparing the shale for retorting.

Finally, the crude shale oil properties differ significantly between the AGR and in-situ processing methods. Specifically, AGR crude shale oil is better suited for distillate fuel production, whereas in-situ processed shale oil is better suited to gasoline production. In addition, it is certain that new refineries and refinery retrofits will be required to process crude shale oil.<sup>177, 178, 179</sup>

Current analysis indicates that domestic oil shale resources contain nearly 1,800 billion barrels of oil. About 84 percent of U.S. oil shale deposits lie in Colorado, ten percent are in Utah, and six percent are in Wyoming.<sup>180</sup> Companies developing oil shale are concentrating in Colorado because of its vast reserves and high quality deposits.

Shale oil is very expensive in terms of resources. It takes a great deal of energy and capital to mine the shale, heat it, process it, and treat the enormous quantities of resultant waste. Both the conventional and in-situ methods use process heat and mechanical energy. (It has been suggested that the in-situ recovery methods use nuclear explosives to break down and heat the fractured rock.)<sup>181</sup>

Oil shale processing also uses large quantities of water, approximately 39 gallons (147.6 liters) per barrel of shale oil. The U.S. Environmental Protection Agency estimates that two to five gallons per ton (.02 liters per kg) of shale will be contaminated by toxic chemicals, minerals, and trace elements as a result of processing.<sup>182</sup> The Colorado Water Conservation Board estimates that a one billion barrel per day oil shale industry would consume 120,000 to 190,000 acre feet of water per year. According to the Western States Water Council, the production of shale oil could compete disastrously with agricultural water demands, as could other western energy conservation industries. The Council points out that, "To allow the energy industry to acquire water rights at the market place could result in the new allocation of limited waters to energy while reshaping established economies with perhaps locally the greatest impact being on irrigated agriculture."<sup>183</sup>

Oil shale ventures have so far been stymied by economic as well as environmental problems. The estimated cost of a barrel of shale oil is \$25 to \$30 in 1979 dollars. The oil shale industry is currently anticipating that hikes in the landed price of OPEC crude and federal subsidies or tax credits will improve the economic viability of their products. Morton M. Winston, President of Tosco Corp., a diversified refining and coal company, envisions the kickoff of the shale oil industry: "The first couple of shale ventures inherently will be very risky from an economic standpoint, but we're optimistic that an energy program that clears up uncertainties about environmental requirements and helps stabilize markets that are capriciously regulated can't help but results in the development of an on-going oil shale industry."<sup>184</sup> Occidental Petroleum, Tosco, and other firms are investing millions of dollars each month in anticipation of the potential profits from oil shale products. Lightweight home heating oil, gasoline, diesel, and jet fuel made from shale oil promise huge profits in future earnings.<sup>185</sup>

In the past, uncertainties have led to project cancellations, but revitalized government interest and the rising price of conventional fuels are giving the oil shale industry new hope. The heyday of the oil shale industry appears to be coming, but serious energy and water limitations must be mitigated first.

### Remote Natural Gas (2.5-11)

Natural gas is a high quality conventional fuel which generally requires little upgrading prior to end use. However, being a gas, the maximum distance it can be economically transported is somewhat limited. Therefore, in order to develop these reserves the gas must be compressed, liquefied (LNG), or converted to another fuel such as methanol. The technologies for LNG and methanol production are commercially available today and "off-the-shelf" packaged plants are readily available from numerous suppliers, particularly for methanol synthesis from natural gas. The major barrier to developing these resources today is economic. LNG and methanol are still not economically competitive with conventional fuels. In addition, with LNG, there are technical and safety issues yet to be resolved.

The remote-natural-gas-to-synthetic-fuels concept is particularly interesting in a strategic sense given the current commercial status of conversion technologies and required construction lead times.

### Future of Synthetic Fuels (2.5-12)

Aside from significant synthetic fuels development efforts undertaken by a number of major U.S. energy corporations, the U.S. government launched a massive \$88 billion synfuels development program in June 1980 when President Carter signed legislation (S. 932) establishing the U.S. Synthetic Fuels Corporation. The Corporation is an independent federal entity charged with providing incentives to private companies to construct synfuels plants. The Corporation's goal is a national synfuels capability of 500,000 barrels per day by 1987 and two million barrels per day by 1992--all from domestic fuel resources.

Under the new Energy Security Act (PL 96-294), the Corporation is charged with primary national responsibility for developing synfuels plants. "Because of the nature of its activities, which are principally to provide financial assistance to the private sector, the Corporation is expected to function much like a private corporation entity such as a bank or other financial institution."<sup>186</sup>

Phase I of the national program is expected to be a "sifting" process in the synthetic fuels effort in which a diversity of processes and technologies will be encouraged in order to determine the best potential for each hydro-carbon feedstock (biomass is also included in the effort). Prior to the expiration of this phase, a detailed report from the Corporation will be submitted to Congress. The report will include:

1. The economic and technical feasibility of each facility, including information on product quality, quantity and cost of production.
2. The environmental effects of operating the facilities, as well as projected environmental damage, including water quantity.
3. Recommendations on the mix of technologies to be supported, and recommendations on subsequent funding phases.

In following this strategy, the Corporation will look at other federal programs such as PL 96-126, the Defense Production Act (Part A), and other DOE synfuels programs. Under the Energy Security Act, the President is given expanded authority within the Defense Production Act to initiate a "fast start" interim synfuels program which will catalyze the national effort in the next few years. The comprehensive strategy to be given to the Congress must be approved by a Joint Resolution in order to initiate the primary funding phase of the national effort, a \$68 billion "set aside" to fund Phase II.

The Corporation will give preference to the following, in order of decreasing priority: 1) Purchase agreements, priced guarantees, and loan guarantees; 2) Loans; and 3) Joint Ventures. Subject to appropriation, the Corporation is authorized to assume obligations up to \$20 billion under PL 96-126 and up to \$3 billion under Defense Production Act authorities. The Corporation is scheduled to terminate on September 30, 1997.

Under the terms of Title II of the Energy Security Act, up to \$1.5 billion is authorized for biomass energy projects with an emphasis on alcohol fuel plants and waste-to-energy facilities. Title III requires the setting of annual energy production and consumption targets by the Department of Energy in order to provide a working mechanism for energy policy cooperation between the Congress and the executive branch of government. Title IV provides for increased funding of a range of energy conservation efforts and small technology development in various solar and renewable energy technologies. Of special interest, from a strategic energy perspective, is a modest program for \$10 million to "demonstrate energy self-sufficiency through the use of renewable energy resources in one or more states" over a three year period.

Specific technologies cited in Title IV for development on a local scale are small hydro resources and photovoltaic solar programs in federal facilities. The Secretary of Energy is given authority to utilize a seven percent discount rate and marginal fuel costs in determining and calculating alternative energy and conservation improvements to federal buildings. Title V establishes a Solar and Conservation Bank within the Department of Housing and Urban Development, which will fund a variety of household and commercial solar and conservation efforts.

Additional sections of the law set up programs for industrial energy conservation, geothermal energy development (\$85 million on FY 1981-85), and environmental assessments of "acid rain" and carbon dioxide problems stemming from synfuel combustion. Title VIII orders the administration to resume filling the Strategic Petroleum Reserve at a rate of at least 100,000 barrels per day.<sup>187</sup>



## Forecasting Electricity (2.6)

Historically, demand forecasting was a straightforward exercise. As the energy economy expanded, the electrical system doubled in size each decade. This process was halted, perhaps permanently, by the 1973-74 oil boycott. Since that winter, demand uncertainties have affected most of the nation's utilities, and historic growth rates have not prevailed.

Forecasts are important since lead times for the construction of new power plants can range from ten to fifteen years (e.g. in the case of large coal and nuclear plants), and utilities must have an idea of future demand to make such large capital investments. One analysis summarizes the issues as follows: "Forecasting is made more complicated by uncertainty over the consumer response to recent price increases and uncertainty over the effect of changes in rate design and changes in the price and availability of oil and natural gas."<sup>188</sup>

Despite current uncertainties in demand for electrical power which affects decisions regarding construction of new power plants, a number of major energy studies predict a major shift to electricity within the next two decades. The following forecasts in Table 2.6-1, compiled from recent reports by national government and industry studies, indicate the predicted supply of electricity in the year 2000 (or as otherwise noted) as a percentage of national energy consumption from all sources.

Table 2.6-1<sup>189</sup>

### ELECTRICITY AS A PERCENTAGE OF U.S. ENERGY IN THE YEAR 2000 (unless otherwise noted)

Resources for the Future	40%
IEA (Institute for Energy Analysis)	50%
CONAES (Committee on Nuclear and Alternative Energy Systems)	36% (2010)
MOPPS (Market Oriented Program Planning Study)	40%
EIA (Energy Information Administration)	35% (1990)
Edison Electric Institute	42%

There is considerable dispute over growth rates, which have dramatically fallen since the Arab embargo of 1973 (California utilities are growing at less than two percent per year), and the relative contribution of electricity as a future energy source. Today, conservation efforts are successful in many areas in dampening demand for electricity. Other factors, such as an increasing tendency towards smaller, more efficient power plants, may serve to slow and even curtail the high growth rates for electricity. The electrical system is changing in a number of ways, and a critical component of this change, smaller systems, has been brought about by a reevaluation of the "economies of scale," that smaller systems may provide.

## Energy Systems and Economies of Scale (2.7)

As we have seen, the electric utility industry began in the late 19th century as a highly decentralized enterprise. Small power facilities served neighborhoods and were fueled largely by coal and hydroelectric power. In the early years of electric power, high costs to consumers were a result of high construction costs and fuel costs. Transmission lines and distribution centers, the essential infrastructure of the industry, were expensive to build and maintain. As the industry grew, costs were reduced by building larger, more efficient power plants and transmission facilities. By 1975, power plants over 500 MW capacity had increased to 222 facilities from 155 in 1950.<sup>190</sup>

The trend towards large electrical power plants and related systems was caused by the desire to improve efficiency by gaining economies of scale in equipment and fuel usage. Small individual electric utilities were consolidated into larger systems.

The concept of size versus efficiency is important in considering any investment project such as a power plant. It is of course not the only efficiency consideration. One criterion which is used to ascertain the optimal size is known as "economies of scale." The concept technically involves the use of the "long-run average (or unit) cost," or LAC. Average cost is obtained by dividing total costs by the level of output (or activity). The reason for the distinction between long-run and short-run is that during the short period, certain factors in production processes (such as the scale of the plant) may be fixed. As the relevant time frame is expanded, however, these initially fixed factors are variable and can be changed in relation to other factors of production. Investment projects are analyzed in terms of their efficiency over a time period that is commensurate with the useful life of their most inflexible ("fixed") factor of production.

Figure 2.7-1 depicts the long-run average cost curve (sometimes referred to as the "planning curve"). The concept of economies of scale is seen by noting that the LAC declines between activity size 0 and activity size  $X_1$ , stays the same until  $X_2$  is reached, and then turns upward as the diseconomies of scale segment of the curve is reached.

When economies of scale exist, long-run average costs fall as activity size increases. This may be due to:

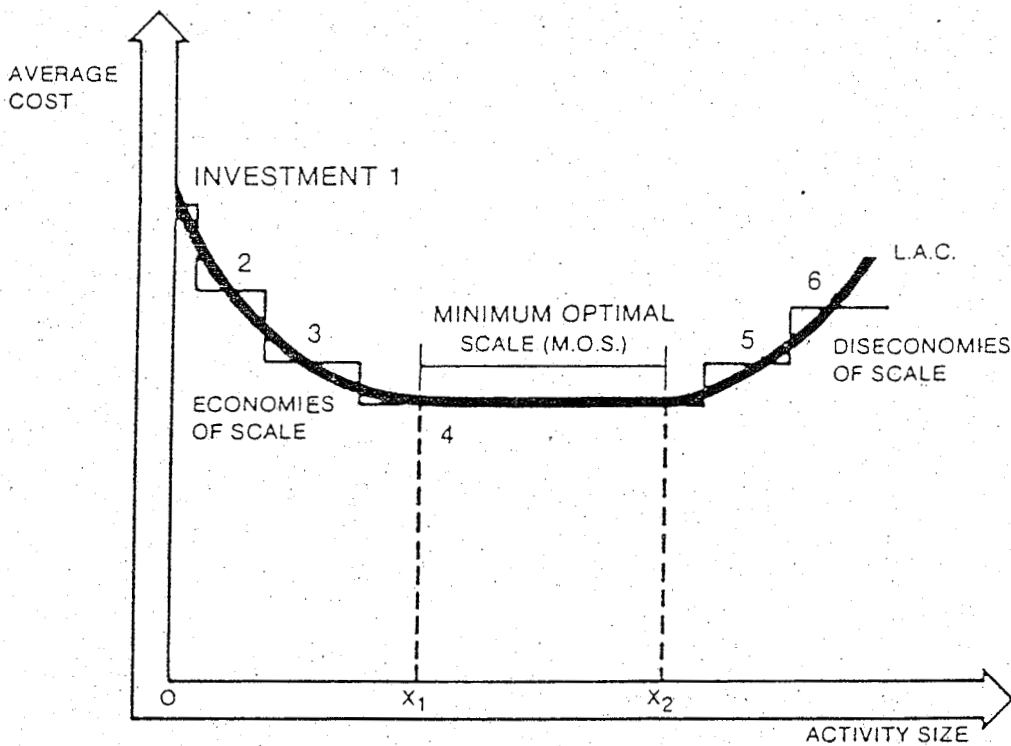
1. Advantages of division and specialization of labor and machinery which are positively correlated with increased size;
2. Larger sizes may eliminate "indivisibilities," or large cost disadvantages accruing to the use of highly specialized and expensive labor and machinery and size less than a certain magnitude;
3. The best use of the latest technology, which is feasible only for large quantities of output;
4. Economies from high volume purchasing and shipping;

5. The availability of necessary maintenance crews and spare parts, in case of breakdown, only at large scales of operation.

Diseconomies of scale occur when the activity size increases beyond the lowest point (or range) of the LAC. An example might be that increasing numbers of workers are assigned to a given unit of equipment, (or conversely, increasing amounts of equipment are assigned to a given work force) resulting in higher unit output costs as production is increased beyond the "optimal" (i.e., most productive) mix.

Figure 2.7-1<sup>191</sup>

LONG-RUN AVERAGE COST CURVE (LAC)



It is difficult to usefully apply the concept of "economies of scale" in a static environment (i.e., for a "snapshot" in time in which technology and other considerations are held constant). To make the analysis more realistic, one important consideration is that activities typically cannot be expanded continuously. Movement along the LAC curve is actually made discreetly, in "step-like" jumps. During the period between the initial investment and the next added increment of investment, excess capacity will exist. An optimal size must be reached to gain the full economies of scale available for this level of investment.

Research by Manne and Erlenkotter has indicated that it is important to consider is the relationships of uncertainty factors (incorporated analytically by economists using the "discount rate").<sup>192</sup> For example, if unstable financial conditions or some other significant cause of uncertainty as to the profitability of a given activity exist, the discount rate (which reflects the uncertainty of future return) will be concomitantly high. This may cause a planner to curtail an investment short of the point of full actual economies of scale as a means of reducing the magnitude of potential loss if the investment, for whatever reason, does not meet "expected" performance.

The market structure in which a certain activity takes place is another consideration relevant to a discussion of economies of scale. If, for example, an industry is a "natural monopoly," i.e., if economies of scale allow a single firm to serve the market at lower unit cost than with two or more firms, then the extent to which the single firm is allowed to grow to its full cost advantage will affect the extent to which the available economies of scale can be realized.

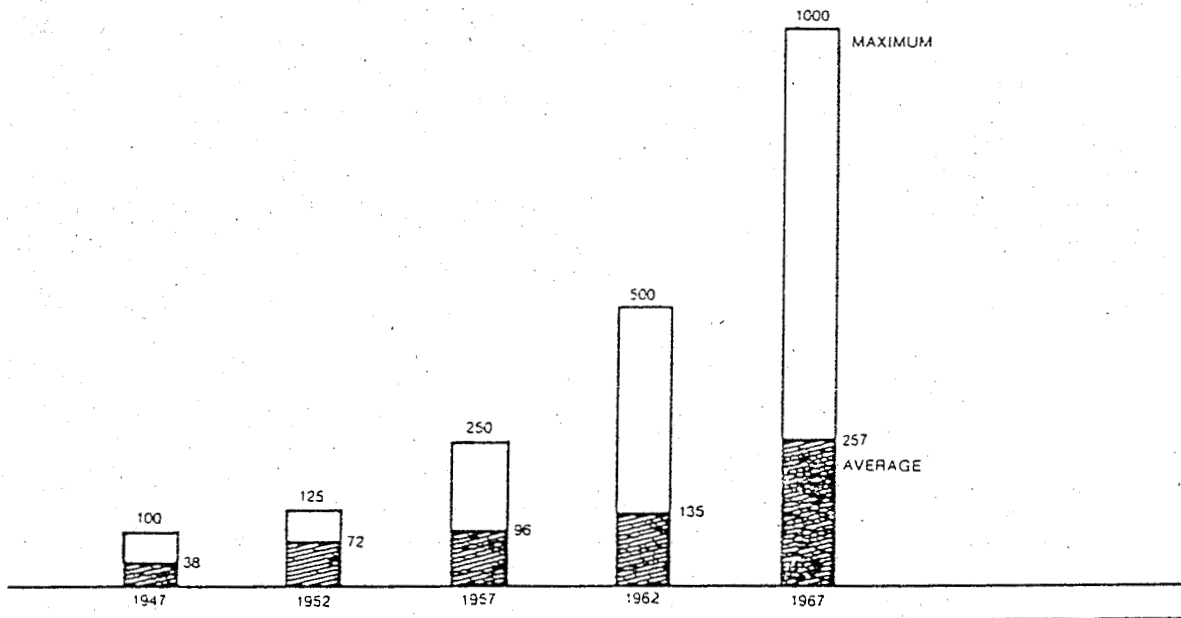
The electric utility industry is a "natural monopoly." Average production costs, for instance, have declined for coal-fired steam-turbine generating plants up to designed plant sizes of at least 750 megawatts. Recent studies, however, have reduced the confidence in continuing advantages of increased scale in the electric utility industry as financial, electrical demand and performance uncertainty has increased.<sup>193</sup>

In a paper presented at the American Power Conference in 1968, R.R. Bennett of Ebasco Services, Inc. predicted that large electric power generating stations in the 1980s would include individual units of 3000 MW and aggregate generating capacity of 12,000 MW. He predicted that, as a consequence of this increase in scale size, most of the small power stations in service at that time would become obsolete and be retired before 1990.

Figure 2.7-2 illustrates the growth trend in average and maximum steam electric generator unit size at the time of Bennett's report.<sup>194</sup> From 1947 to 1967 the average unit size increased by more than 700 percent (i.e., from 38 MW to 267 MW). During the same period, the largest unit size increased 1,000 percent (from 100 MW to 1,000 MW).

Figure 2.7-2<sup>195</sup>

AVERAGE AND MAXIMUM STEAM UNIT SIZE, 1947-1967, IN MEGAWATTS



Nuclear units enjoyed similar increases in scale as illustrated in Table 2.7-1.<sup>196</sup> At the time of Bennett's report, it was estimated that the scale size of 1,100 MW for nuclear units was only a temporary plateau. Similarly, General Electric Company studies predicted Boiling Water Reactor (BWR) nuclear steam supply systems with unit sizes up to 10,000 MW. Similar studies by Gulf Atomic indicated that 10,000 MW high temperature gas-cooled reactors were also feasible, and for sodium-cooled reactors, scale sizes were extrapolated to even greater scales. Clearly, none of this mega-scale construction of facilities has occurred.

Table 2.7-1<sup>197</sup>

INCREASE IN THE SIZE OF NUCLEAR UNITS

<u>Year of Initial Operation</u>	<u>Largest Nuclear Unit Installed in Year, MW</u>	<u>Average Nuclear Unit Installed in Year, MW</u>
1960	200	200
1961	175	175
1962	255	120
1963	70	40
1964	---	---
1965	---	---
1966	790	270
1967	40	40
1968	640	420
1969	1,030	590
1970	1,150	730
1971	1,150	770
1972	1,100	850
1973	1,100	860

The design factors used in the above mentioned engineering-feasibility studies included assessments of future supplies of cooling water and fuel availability, environmental limitations, electric system limitations, limitations on the design, manufacture and shipment of major plant components, and land requirements. Yet, despite the fact that these engineering analyses were performed by the most skilled technical people of the time and at considerable expense, they were wrong. The reason is that other (uncertainty) factors assumed to be "constant" in these studies were actually variable.

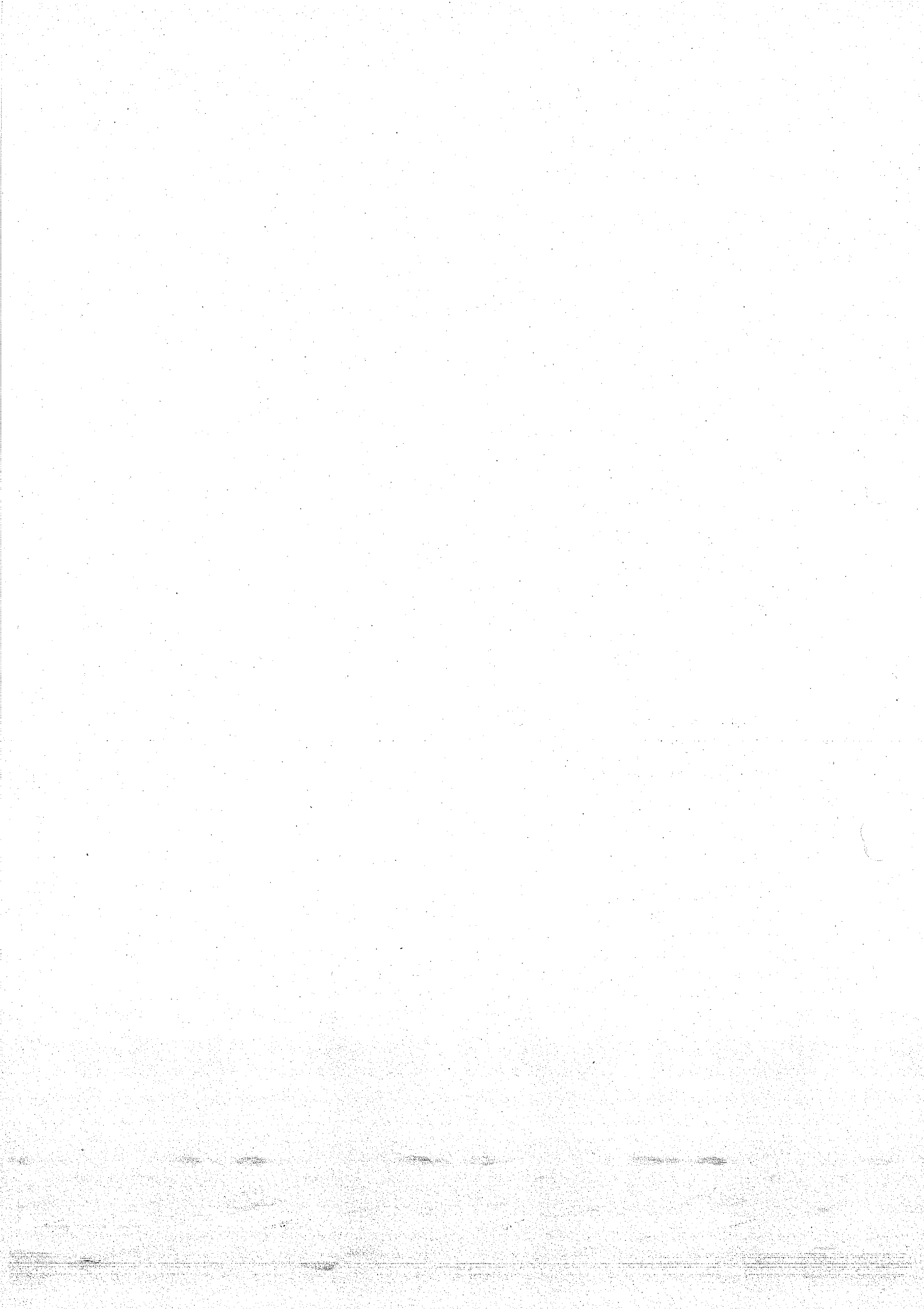
In a recent article published by the International Institute for Applied Systems Analysis, such non-economic factors (uncertainty factors) relevant to choice of scale (i.e., political, social, economic, technological, organizational, managerial, and financial) were examined. It was found that the relative "discount" significance of these factors varies not only from case to case, but also with the level of scale (size of investment) decision considered.<sup>198</sup>

Three major sources of "diseconomies of scale" found above were:

1. The engineering cost of the generation equipment is by no means the total capital cost of a power station. Construction time for very large units of plant size has increased because of the present necessity of extended, on-the-construction-site fabrication. This leads to greater accumulated financial charge even before the plant starts to earn revenue.



2. The more intense demands on materials and components (e.g. the greater the length of boiler tubing), the greater the probability of breakdowns of equipment, thereby reducing effective available capacity in actual operation.
3. The greater time lags required in the planning of large plants' construction mean that forecasts have to be made further ahead, with correspondingly greater uncertainty. Therefore, the level of reserve capacity to be installed to achieve a specified level of security of supply must also increase.<sup>199</sup>



## The Trend to Small Power Plants (2.8)

In a recent study conducted by Andrew Ford of the Los Alamos Scientific Laboratory (LASL) and Irving Yabroff of SRI, International, small-scale coal-fired power plants were compared to large plants.<sup>200</sup> The study stems from the \$3 billion proposed project at Kaiparowits, Utah, in which a 5,000 MW coal-fired power plant was abandoned before completion after thirteen years of an unresolved controversy over polluting the air of surrounding national parks.<sup>201</sup> Several other power plant sites have been abandoned lending credence to the theory that perhaps it is not necessarily true that the "bigger" plants are "better," as it once seemed. The study concludes that decentralization is necessary for the following reasons:

Although the small plants have a higher capital cost per kilowatt of installed capacity and their dispersed siting requires a greater investment in railroad and transmission lines, they still enjoy eleven percent capital cost advantage over the large plant because less capacity must be built.\* For the same reason, lower annual operating and maintenance costs for the generating facilities more than offset the small plants' higher fuel cost to give them a two percent annual cost advantage.<sup>202</sup> (See Table 2.8-1).

Having established the cost/benefit trade-offs available by use of the small-scale plant, Ford next considered "system reliability." Every generating unit is periodically shut down for repairs for a certain number of hours every year. To also account for possible accidents that would temporarily cut off electricity supply, all generating systems have a "reserve margin." Ideally the reserve margin ranges from fifteen percent to 25 percent above peak load demands. In practice, larger units require larger reserve margins because they have a higher "forced outage rate" (necessary repair and maintenance time), and because they must be able to replace a large percentage of total capacity (reflecting the large share of electricity generation they have in the first place). Using several different estimates of capital costs, forced outage rates, and fuel costs, Ford concluded that small plants provided a greater degree of reliability, and that overall they proved to be more economical than large plants.

\*Note: Ford's study is based on a realistic comparison of a large-scale plant scenario and a small-scale plant scenario. Each power plant produced 3,000 MW of coal-fired electricity; the large plant's electricity came from four 750 MW units whereas the small plant used six 500 MW units to generate electricity. By studying each plant's effective load-carrying capability (ELCC), however, Ford discovered "that only nine 250 MW units provide approximately the same effective addition in system capacity as four 750 MW units."<sup>203</sup>

Table 2.8-1<sup>204</sup>

PRESENT VALUE OF CAPITAL AND OPERATING COST, SMALL UNIT  
AND LARGE UNIT PLANS (IN MILLIONS OF 1977 DOLLARS)

	<u>SMALL STATION PLAN (Nine 250 MW Units)</u>	<u>LARGE STATION PLAN (Four 750 MW Units)</u>
<u>Present Value of Capital Cost</u>		
Generation	\$ 609.7	\$ 829.3
Transmission	256.2	253.4
Coal Transportation	<u>105.2</u>	<u>84.0</u>
<u>Total Present Value Capital Cost</u>	\$ 971.1	\$1,166.7
<u>Present Value of Operating Cost</u>		
Generation	\$2,369.4	\$2,415.7
Transmission	69.1	69.1
Coal Transportation	<u>50.5</u>	<u>35.6</u>
<u>Total Present Value Operating Cost</u>	\$2,489.0	\$2,520.4
<u>Total Present Value Cost</u>	\$3,460.1	\$3,687.1

Similar to Ford's reliability measure, another method of measuring system reliability, indicating the disparity between "availability" rates of small- and large-scale power plants, was undertaken by Anson in 1977 Electric Power Research Institute study. Anson reported that "the availability of baseload units averaged 83 percent for units smaller than 380 MW, 77 percent for units between 390 MW and 599 MW, and 73 percent for units larger than 600 MW."<sup>205</sup>

Small power plants offer numerous advantages during the multi-faceted, complicated site selection process which provide Ford with his third set of criteria. Two important advantages are: 1) The smaller plant emits fewer pollutants than a large plant, thus enabling small plant siting in locations where large power plants would be unacceptable; and 2) "Smaller power plants have historically required about twenty percent less time to gain permit approvals."<sup>206</sup> Small plants also face one significant disadvantage during site selection: More sites for the increased number of plants must be found and approved. Ford claims that presently "the procedural complexity of undergoing repeated site approval hearings probably outweigh, in the long run, the greater ease any single small plant may have in gaining approval."<sup>207</sup>

The LASL group points out that the prevailing high level of uncertainty makes the accuracy of future projections difficult to achieve. This can cause severe capital losses to a utility that overbuilds its plant capacity based on inaccurate forecasts. The advantage that construction of small plants offers is the substantially shorter lead times compared to larger plants. A typical large plant requires three to four years for licensing and seven to nine years to construct. A small plant only requires two to three years for permit approval and four to five years to construct.

The degree of uncertainty in forecasting is therefore somewhat diminished when the lead time is not as long, which improves the accuracy of electricity supply and demand projections. Thus, the likelihood of overbuilding or underbuilding plant capacity is lessened. Another benefit derived from a shorter forecasting time frame is that "it also makes the utilities' arguments for power needs more convincing before state commissions."<sup>208</sup>

Another advantage of small plants relates to the levels of water usage. Smaller power plants use less water than larger plants, and environmental impacts will not be as significant as with a single, large unit. Thus, the number of possible site locations is expanded and the likelihood of permit approval improves.

A study conducted by Leonard of the Radian Corporation and Miller of the University of Oklahoma indicated that "the construction of dispersed, small units could allow greater exploitation of resources without an increase in problems associated with air pollution."<sup>209</sup> Additionally, a Clark University study concluded that "coal plants of 400 MW or less and nuclear plants of 800 MW or less have distinctly better performance records than large plants of both types."<sup>210</sup>

A further indication of the trend toward small power plants can be seen from several developmental efforts by utilities and the nuclear industry to scale down fusion and thermal nuclear plants. Recognizing that, "Huge (fusion) facilities have not proved to be an effective focus for development programs to get new commercial enterprises started," C.P. Ashworth, a mechanical engineer with California's Pacific Gas & Electric Company, presented a cogent argument for "small fusion" at a 1980 American Association of the Advancement of Science symposium.<sup>211</sup>

Based on the experience of the scientific community, the nuclear industry and utilities with fission reactors, Ashworth argued against the assumption that huge-scale facilities must be developed to bring fusion technology "on-line." The massive amounts of capital and materials required have tended to focus the research and development efforts on one or two large projects.

Huge projects represent long periods where nothing much that looks like progress appears to be getting done at a time when cash outlays are very large. Huge first-of-a-kind projects are very prone to schedule lengthening which makes these periods of no progress become interminable. Schedule stretchout seems to breed conditions which lead to delays on top

of delays. Eventually, program time becomes extended to the point where a favorable outcome is no longer assured no matter how important and well justified the concept. Thinking big has affected the pace, and quite possibly in some cases the outcome, in many energy development attempts--notably breeders, gas reactors, coal gasification, uranium enrichment and MHD. It can be argued that in these cases there was no choice. But in fusion, there appear to be choices that could speed up development.<sup>212</sup>

Large-scale facilities not only set the pace of development, they also set the course. This tends to preclude alternative designs and concepts from development budgets and to create a dampening effect on risky but necessary innovation. "With the small facility focus, many inputs get into the act, including rivalry and competition between institutions pursuing different projects--the small facilities route can lead us to attractive commercial fusion energy sooner."<sup>213</sup>

The use of large-scale nuclear facilities for electric power production has become more and more questionable in terms of the expense and safety factors involved. Atomic Energy of Canada, Ltd. (AEC), a government-owned nuclear company, recently announced plans to develop the Slowpoke, (Safe low-power critical experiment), "the cheapest and smallest reactor ever designed for commercial use."<sup>214</sup>

Rather than provide superheated steam to run electrical turbines, Slowpoke would produce hot water to heat buildings. Small-scale reactors for direct heat applications are being researched in France, Scandinavia and the Soviet Union. AEC estimates that Slowpoke can be built for as little as \$850,000. The cost for a thermal kilowatt from Slowpoke would be \$425 compared to \$400 to \$465 for equivalent power generated by conventional nuclear reactors.<sup>215</sup>

The advantages of the small-scale approach to nuclear reactors are in the sheer simplicity of design.

The reactor is modeled after small, pool-type research reactors used at many universities. Its vessel is a 25 foot-deep concrete-lined pool dug in the ground. The small fuel core is immersed directly in the water-filled pool. The nuclear reaction heats the water in the pool to 190°F and the heat is removed through a double loop of heat exchangers that isolate the heated water from the radioactive core.<sup>216</sup>

Expensive cost and potentially faulty safety factors associated with large-scale nuclear power plants can be avoided with development of small systems such as Slowpoke.

The Slowpoke concept is especially interesting in light of its potential for dispersion and decentralization.



Officials at Canada's AEC point out that Slowpoke...does not require the elaborate core-cooling safeguards of the large reactors, and it eliminates the need for district distribution systems required for French and Soviet approaches...Slowpoke will offset the economies of scale of the bigger projects...(and may be used) in many parts of the world where petroleum is expensive and district heating systems are not practical.<sup>217</sup>

All of the above studies lead to the conclusion that long lead times, high capital costs, shrinking economies of scale, and operation reliability problems with large units could be lessened with smaller, dispersed power plants.<sup>218</sup>

## SECTION 2

### ENERGY: EXISTING SYSTEMS AND TRENDS

#### FOOTNOTES

1. Messing, Marc, et. al, Centralized Power, Washington, D.C., Environmental Policy Institute, March, 1979, p. 15.
2. Ehrlich, Paul, Ann Ehrlich and John Holdren, Ecoscience, W. H. Freeman and Co., San Francisco, Ca., 1979, p. 416.
3. DOE/EIA, Monthly Energy Review, May, 1980, pp. 25-26.
4. Clark, Wilson, Energy for Survival, Anchor Books, Garden City, N.Y., 1974, pp. 28-29.
5. Landsberg, Hans and Sam Schurr, Energy in the United States: Sources, Uses and Policy Issues, New York, Chapter 1.
6. Schurr, Sam and Bruce Netschert, Energy in the American Economy: 1850-1975, Baltimore, 1960, pp. 652-653.
7. Clark, op. cit., p. 42.
8. DOE/EIA, op. cit., p. 6.
9. Council on Environmental Equality, Environmental Equality, Tenth Annual Report, December 1979, p. 321.
10. DOE/EIA, op. cit., p. 6.
11. Clark, op. cit., p. 60.
12. Congressional Research Service (CRS) National Energy Transportation, Volume 1, Washington, D.C., May, 1977, p. 2.
13. DOE/EIA, op. cit., p. 6.
14. Mineral Resources and the Environment, National Academy of Sciences, Washington, D.C. 1975, p. 334.
15. Energy Statistics, Committee of Finance, U.S. Senate, U.S. Government Printing Office, Washington, D.C., July 4, 1975, p. 8.
16. Mineral Resources and the Environment, op. cit.
17. Crude Petroleum: Petroleum Products and Natural Gas Liquids Annual Summary, Energy Information Administration, Department of Energy, 1973 and 1979.
18. DOE/EIA, op. cit., p. 28.

FOOTNOTES (Continued)

19. Theobald, P. K., et. al., "Energy Resources of the U.S.," USGS Circular 650, USGPO, Washington, D.C., 1972, p. 1.
20. Ibid., p. 1.
21. Table 2.2-1, "U.S. Crude Oil Production (Thousands of Barrels)," Source: Ibid.
22. Energy Statistics, op. cit., p. 8.
23. Moody (Mobil), 1975.
24. CRS, op. cit., pp. 320-330.
25. CIA, International Energy Statistical Review, July 29, 1980, p. 4.
26. "The Push to Make Tertiary Recovery Pay Off," Business Week, November 30, 1974, p. 51.
27. "Pipeline Economics," Oil and Gas Journal, August 13, 1979, p. 69.
28. CRS, op. cit., p. 182.
29. Figure 2.2-1, "Total Petroleum Movement Map," Source: Prepared for DCPA by the U.S. Geological Survey, 1965.
30. DOE/EIA, Energy Data Reports, "Petroleum in the United States and U.S. Territories, January 1, 1979," June 28, 1979, p. 3.
31. Ehrlich, op. cit., p. 415.
32. Ibid., p. 416.
33. CRS, op. cit., p. 240.
34. DOE/EIA, op. cit., p. 6.
35. CRS, op. cit., p. 343.
36. DOE/EIA, op. cit., p. 6.
37. Ehrlich, op. cit., pp. 427-429.
38. DOE/EIA, op. cit., p. 48.
39. Federal Energy Administration (FEA), National Energy Administration, USGPO, Washington, D.C., March, 1976.

FOOTNOTES (Continued)

40. Tiratsoo, E. N., Natural Gas: A Study, Plenum Press, New York, 1976.
41. Energy Data Reports, op. cit., p. 12.
42. CRS, op. cit., p. 9.
43. Davis, Lee Niedringhaus, Frozen Fire, Friends of the Earth, San Francisco, Ca., 1979, p. 10.
44. Ibid., p. 19.
45. Ibid., p. 41.
46. Ibid., p. 11.
47. Ibid., p. 88.
48. Ibid., p. 88.
49. Ibid., pp. 88-93.
50. Ibid., p. 104.
51. American Gas Association (AGA) Gas Facts, Arlington, Virginia, 1978, p. 53.
52. DOE/EIA, op. cit., p. 48.
53. AGA, op. cit.
54. CRS, op. cit.
55. DOE/EIA, op. cit., p. 6.
56. DOE/EIA, op. cit., p. 6.
57. Figure 2.2-2, "Natural Gas Movement Map," Source: Prepared for by DCPA by the U.S. Geological Survey, 1965.
58. DOE/EIA, op. cit., p. 6.
59. FEA, op. cit., p. 2.
60. CRS, op. cit., p. 21.
61. Phillips, James G., "Energy Report: Environmentalists, Utilities Argue Over East, West Mining," National Journal Reports, Washington, D.C., 1974.

FOOTNOTES (Continued)

62. Cook, Earl, Man, Energy, Society, W. H. Freeman and Co., San Francisco, Ca., 1976, p. 81.
63. Ibid., pp. 79-81.
64. Ibid., pp. 79-81.
65. McCormick, John, "Facts About Coal in the United States," Environmental Policy Center, Washington, D.C., 1975, p. 8.
66. DOE/EIA, op. cit., p. 56.
67. CRS, op. cit., p. 144.
68. Ibid., p. 144.
69. CRS, op. cit., pp. 35-36.
70. Ibid., p. 75.
71. National Academy of Sciences, National Academy of Engineering, Rehabilitation Potential of Western Coal Lands, Ballinger Publishing Co., Cambridge, Ma., 1974, p. 101.
72. Figure 2.2-3, "Coal Movement Map," Source: Prepared for DCPA by the U.S. Geological Survey, 1965.
73. Ibid., p. 80.
74. Ibid., p. 85.
75. EIA Monthly Energy Review, "Status of Nuclear Reactor Units," October, 1980.
76. CRS, op. cit., p. 382.
77. CRS, op. cit., p. 397.
78. "Known U.S. Uranium Reserves Won't Meet Demand," USGS Press Release, December, 10, 1975.
79. Ibid.
80. "Pumping Out the Yellowcake," Business Week, January 19, 1976, pp. 30-N.
81. McFadden, James, et al., "Energy Input/Output Analysis for Nuclear Power Plants," Atomic Industrial Forum Meeting, Boston, Ma., October 28, 1975.

FOOTNOTES (Continued)

82. "Why Atomic Power Dims Today," Business Week, November 17, 1975, pp. 98-106.
83. U.S. Department of Energy Press Release, E-76-066, March 4, 1976.
84. Ehrlich, op. cit., p. 434.
85. CRS, op. cit., pp. 408,409.
86. Ibid., p. 416.
87. Figure 2.2-4, "Diagram of Nuclear Fuel Cycle," Source: CRS, op. cit., p. 378.
88. Ibid., pp. 422-425.
89. Cook, op. cit., p. 37.
90. Cook, op. cit., pp. 37-38.
91. CRS, op. cit., pp. 428 - 429.
92. Ehrlich, op. cit., pp. 432-433.
93. Figure 2.2-5, "Nuclear Fuel Movements Map," Source: Prepared for DCPA by the U.S. Geological Survey, 1965.
94. Clark, op. cit., p. 35.
95. U.S. Army Corps of Engineers, Estimate of National Hydroelectric Power Potential at Existing Dams, July, 1977.
96. DOE/EIA, op. cit., p. 6.
97. Ibid., p. 6.
98. U.S. Army Corps of Engineers, op. cit.
99. Cook, op. cit., p. 307.
100. U.S. Army Corps of Engineers, op. cit.
101. Ibid.
102. CRS, op. cit., p. 349.
103. Ibid., p. 357.
104. U.S. Department of Energy, Energy Data Reports, "Statistics of Privately Owned Electric Utilities in the U.S.," Pub. #DOE-EIA-0044, 1978.



FOOTNOTES (Continued)

105. CRS, op. cit., p. 350.
106. Messing, op. cit., p. 10.
107. CRS, op. cit., p. 353.
108. Ibid., p. 350.
109. Ibid., p. 357.
110. Table 2.3-1, "Miles of Transmission in Use at 230 KV or Above (Thousands of Miles)," Source: Messing, op. cit., p. 353.
111. CRS, Map #14.
112. Ibid., pp. 353-354.
113. Vennard, Edwin, The Electric Power Business, Second Edition, McGraw-Hill Book Co., New York, N.Y., 1970, pp. 41-43.
114. Messing, op. cit., p. 15.
115. Vennard, op. cit., p. 83.
116. Messing, op. cit., pp. 23-34.
117. Ibid., p. 3.
118. U.S. Department of Energy, op. cit., p. 18.
119. Messing, op. cit., pp. 14-16.
120. Ibid., pp. 14-16.
121. Ibid., p. 18.
122. Ibid., p. 21.
123. Dillon, Timothy, "Title I of PURPA: The Effect of Federal Intrusion into Regulation of Public Utilities," William and Mary Law Review, Vol. 21, 1979, p. 491, and Jaskow, Paul L., "Public Utility Regulatory Policy Act of 1978: Electric Utility Rate Reform," Natural Resources Journal, Vol. 19, October, 1979, p. 787.
124. U.S. Department of Energy, op. cit., p. 34.
125. Hill, Philip G., Power Generation: Resources, Hazards, Technology, and Costs, The MIT Press, Cambridge and London, 1977, p. 229.
126. Probstein, R. F. and H. Gold, Water in Synthetic Fuel Production, 1978, p. 16.

FOOTNOTES (Continued)

127. Ibid., pp. 16-22.
128. California Energy Commission (CEC) and Arthur D. Little, Inc., California Clean Fuels Study, April, 1978, p. 109.
129. Department of Energy, Draft Commercialization Strategy Report for Oil Shale, GPO, TID-2845, 1978, p. 43.
130. Probst, op. cit., p. 18.
131. Office of Technology Assessment, An Assessment of Oil Shale Technologies, GPO, June, 1978, p. 5.
132. Figure 2.5-1, "Coal Fields of the Conterminous United States," Source: Energy and Defense Project.
133. Table 2.5-1, "Demonstrated U.S. Coal Reserves by Region and Method of Mining ( $10^9$  Tons)," Source: Energy and Defense Project.
134. Department of Energy, Overview of Technology Commercialization Assessment, US-0003, GPO, November, 1978, pp. 43-57.
135. Peterson, D. B., Coal Utilization and Conversion Technologies, State-of-the-Art, California Energy Commission, September, 1978, pp. 8-21.
136. CEC, Commercial Status: Electric Generation and Nongeneration Technologies, State of California, Sacramento, Ca., April, 1980, pp. 82-83.
137. Department of Energy, Overview of Technology Commercialization Assessment, op. cit., p. 22.
138. CEC/Little, op. cit., pp. 126-131.
139. CEC, Commercial Status, op. cit., pp. 82-83.
140. Figure 2.5-2, "Oil Shale Areas of the Green River Formation in Colorado, Utah, and Wyoming," Source: Energy and Defense Project.
141. Table 2.5-2, "Synthetic Fuels from Coal," Source: Energy and Defense Project.
142. Figure 2.5-3, "Coal Gasification," Source: Energy and Defense Project.
143. CEC, Commercial Status, op. cit., p. 84.
144. Ibid., p. 84.

FOOTNOTES (Continued)

145. CEC/Little, op. cit., p. 27.
146. Table 2.5-3, "Selected Medium-Btu Coal Gasification Processes," Source: Energy and Defense Project.
147. CEC, Commercial Status, op. cit., p. 91.
148. Ibid., p. 91.
149. Ibid., p. 91.
150. Department of Energy, Draft, Commercialization Strategy Report for Oil Shale, op. cit., p. 80.
51. CEC/Little, op. cit., p. 129.
152. Peterson, op. cit., p. 29.
153. CEC, Commercial Status, op. cit., pp. 91-92.
154. Ibid., p. 94.
155. CEC, Commercial Status, op. cit., p. 94.
156. CEC/Little, op. cit., pp. 147-155.
157. CEC, Commercial Status, op. cit., pp. 95-96.
158. Ibid., p. 97.
159. Probststein, op. cit., pp. 133-142.
160. CEC, Commercial Status, op. cit., p. 99.
161. Ibid., p. 99.
162. Probststein, op. cit., pp. 25-27.
163. Office of Technology Assessment, op. cit., p. 119.
164. Figure 2.5-4, "Oil Shale Utilization," Source: Energy and Defense Project.
165. Department of Energy, Draft Commercialization Strategy Report for Oil Shale, op. cit., p. 19.
166. Probststein, op. cit., pp. 151-152.

FOOTNOTES (Continued)

167. Department of Energy, Draft Commercialization Strategy Report for Oil Shale, op. cit., pp. 22-49.
168. Office of Technology Assessment, op. cit., pp. 3-11.
169. Department of Energy, Draft Commercialization Strategy Report for Oil Shale, op. cit., pp. 22-49.
170. Office of Technology Assessment, op. cit., pp. 131-137.
171. Department of Energy, Draft Commercialization Strategy Report for Oil Shale, op. cit., pp. 22-49.
172. Office of Technology Assessment, op. cit., p. 137.
173. Department of Energy, Draft Commercialization Strategy Report for Oil Shale, op. cit., pp. 22-49.
174. Office of Technology Assessment, op. cit., pp. 137-139.
175. Department of Energy, Draft Commercialization Strategy Report for Oil Shale, op. cit., pp. 22-49.
176. Office of Technology Assessment, op. cit., pp. 137-153.
177. Department of Energy, Draft Commercialization Strategy Report for Oil Shale, op. cit., pp. 22-49.
178. U.S. Department of Energy, Overview of Technology Commercialization Assessment, op. cit., p. 61.
179. Office of Technology Assessment, op. cit., pp. 153, 154.
180. Federal Energy Administration, Project Independence Blueprint, Final Task Force Report, Potential Future Role of Oil Shale: Prospects and Constraints, November, 1974, pp. 1, 2.
181. Lewis, A.E., Nuclear In-Site Recovery of Oil from Oil Shale, Lawrence Livermore Laboratory, University of California, September, 1973.
182. U.S. Environmental Protection Agency, Oil Shale and the Environment, Office of Research and Development, Washington, D.C., October, 1977, pp. 6-15.
183. Western States Water Council, Western States Water Requirements for Energy Development to 1990, Salt Lake City, November, 1974, p. 39.

FOOTNOTES (Continued)

184. Sansweet, Stephen J., "Energy Hope: An Oil Shale Industry Appears to be Nearing, But Problems Remain," The Wall Street Journal, August 16, 1979.
185. Schuyten, Peter J., "Occidental Bullish on Shale Oil," The New York Times, July 2, 1979.
186. S932, The Energy Security Act, enacted June, 1980.
187. Ibid.
188. Ford, Andrew and Irving W. Yabroff, "Defending Against Uncertainty in the Electric Utility Industry," in William S. Gouse, Energy Systems and Policy, Vol. 4, No. 1-2, Crane Russak, N.Y., 1980, p. 58.
189. Table 2.6-1, "Electricity as a Percentage of U.S. Energy in the Year 2000 (unless otherwise noted)," Source: Schurr, Sam H., Energy in America's Future: The Choices Before Us, Johns Hopkins University Press, Baltimore and London, 1979, p. 195.
190. Congressional Research Service (CRS), Centralized vs. Decentralized Energy Systems, May, 1979, p. 11.
191. Figure 2.7-1, "Long Run Average Cost Curve," Source: Energy and Defense Project.
192. Manne, Alan S., ed., Investments for Capacity Expansion, Chapter 2, The MIT Press, Cambridge, Ma., 1967.
193. Boiteux, Marcel, "Electric Energy: Facts, Problems, Prospects," in James P. Nelson, ed., Managerial Cost Pricing in Practice, Prentice-Hall, Englewood Cliffs, N.J., 1964,
194. Bennett, R. R., "Planning for Power - A Look at Tomorrow's Station Sizes," IEEE Spectrum, September, 1968.
195. Figure 2.7-2, "Average and Maximum Steam Unit Size, 1947-1967, In Megawatts," Source: Energy and Defense Project.
196. Bennett, op. cit.
197. Table 2.7-1, "Increase in the Size of Nuclear Units," Source: Bennett, op. cit.
198. Cantley, M. F. "Big, Small or Beautiful: Questions of Scale," Options '79, 3rd Quarterly News Report published by the International Institute for Applied System Analysis, September, 1979.
199. Ibid.

## FOOTNOTES (Continued)

200. Ford, Andrew and Irving W. Yabroff, "Defending Against Uncertainty in the Electric utility Industry," Submitted for publication in Energy Systems and Policy, 1979.
201. Ford, Andrew, "A New Look at Small Power Plants, Is Smaller Better?" Environment, Vol. 22, No. 2, March, 1980.
202. Ibid., p. 29.
203. Ibid., p. 29.
204. Table 2.8-1, "Present Value of Capital and Operating Costs, Small Unit and Large Unit Plans (In Millions of 1977 Dollars)," Source: Ibid., p. 30.
205. Loose, Veone W. and Theresa Flaim, "Economies of Scale and Reliability: The Economics of Large vs. Small Generating Units," in William S. Gouse, Energy Systems and Policy, Vol., 4, No. 1 and 2, Crane Russak, New York, 1980.
206. Calver, J. R., "Licensing Coal-Fired Power Plants," Power Engineering, January, 1978, pp. 34-42, as quoted in Environment, Vol. 22, No. 2, March, 1980, p. 29.
207. Environment, op. cit., p. 29.
208. Ford, Andrew, "Reconsidering Smaller Power Plants," Electrical World, July 1, 1979, p. 37.
209. "Powerplant Size Studies Show Big Is No Bargain," ENR-McGraw Hill's Construction Weekly, May 24, 1979, p. 39.
210. Ibid., pp. 39-40.
211. Ashworth, C.P., "Small Pilot Plants - Let's Bring Fusion Commercialization Down to Earth," Reprint of Delivered Address to the American Association of the Advancement of Science Symposium, "The Prospects of Fusion Energy as a Commercial Power Source," San Francisco, January 8, 1980, p. 3.
212. Ibid., p. 3.
213. Ibid., p. 4.
214. "Downsizing Nuclear Plants," Business Week, November 10, 1980, p. 144.
215. Ibid., p. 144.



FOOTNOTES (Continued)

216. Ibid., p. 144.

217. Ibid., p. 144.

218. ENR- McGraw Hill's Construction Weekly, op. cit., p. 39.

SECTION 3

DISPERSED AND RENEWABLE ENERGY SYSTEMS

## DISPERSED/RENEWABLE ENERGY SYSTEMS (3.0)

### Introduction and Overview (3.1)

In this section, a range of alternatives to centralized energy systems are categorized and discussed. The rapid escalation of fossil fuel use and the development of materials-intensive energy technologies favored the development of economics of scale for centralized energy facilities. Today and in the future, growing energy demands and national vulnerability considerations point to a new potential for exploiting dispersed and renewable energy sources and technologies.

Traditionally, energy needs have been met by adding new capacity to the electrical system, drilling new oil wells, building new energy facilities, importing foreign resources and extending the centralized production and distribution systems. The challenge of developing less centralized energy systems is one which affects all elements of the society, from economic planners in the private sector to government regulators. A recent conference of leading government and industry officials noted that decentralized electric generation systems conferred benefits such as short lead times in construction, reduced capital requirements, greater efficiency, and reduced vulnerability to fuel shortages. Conversely, disadvantages were seen as difficulties with system integration, need for back-up power, and a limited but continued dependence of fossil fuels. The conference proceedings concluded:

The potential for decentralized technologies as fuel savers or displacers in the electrical sector in the next twenty to thirty years is high—up to 20-25 percent of future generating capacity. These technologies include principally the solar ones (thermal, photoovoltaic, wind machines, hydro); conservation technologies such as heat pumps, new appliances, and insulation; and cogeneration and fuel cells using fossil fuels. These technologies, especially the solar ones, are highly capital, materials and energy intensive during the build-up time of their deployment and so their benefits need to be discounted at least over 20- to 30-year time periods. Also, a production base for decentralized technologies needs to be established and their equitable treatment in the rate structure needs to be formulated.

Current R & D activities funded by the government, not-for-profits and industry provide a spectrum of innovative opportunities. The problem is to demonstrate that these technologies can provide economic and reliable service on the scale needed by users. How to finance these operational demonstrations is an open question: a proper balance of government, private, and ratepayer investments needs to be formulated. The goal should be to provide users with a wide

range of true economic alternatives from which they can select the technologies of greatest utility to them, subject to governmental policies and regulations on rates, the environment, fuel use, and the health and safety of the public. The process of choice among these technologies, and of their demonstration, is the determinate question, rather than the establishment of specific end results on an a priori basis.<sup>1</sup>

From a strategic perspective, the technologies considered in Section 3 are all capable of contributing to national, regional, and local energy needs. They range from conservation strategies, which will play a major role in reducing oil dependence and vulnerability, to future incorporation of solar, small hydro, wind and other renewable technologies into the nation's energy system.

Within a relatively short time, combinations of these alternative technologies can be integrated with existing systems. Over a longer time frame many of these technologies may replace conventional systems and usher in a less dependent, more secure energy future for the United States.

## Energy Conservation (3.2)

### Introduction (3.2-1)

At present and for the foreseeable future, attempts to increase national energy conservation and improve the efficiency of energy use will be our major strategic energy "source." Unlike new energy facilities which take years to construct and often entail substantial capital investments, most conservation and efficiency options are available to the U.S. now, at costs below those of imported fuels and new facilities.

Robert Stobaugh and Daniel Yergin recently summarized the significance of moving boldly and rapidly to implement energy conservation:

The telescoping of the energy emergency in 1979 has greatly increased the urgency of early action. As things stood in 1978, and given the decision now made to decontrol oil prices, we might have hoped to continue with 'business as usual' on energy conservation, allowing higher prices to work through the economy and gradually cause us to increase energy efficiency....

In current circumstance, however, such a course will not be adequate. The gap between energy resources and energy demand would be closed by "unproductive conservation" — the shutting down of factories, higher unemployment, higher inflation, offices too warm in the summer for efficient work, colder houses, a choice for some between food and fuel....

Far more desirable is the alternative of accelerated energy efficiency. Our whole industrial system is like a vehicle built to operate on \$3 oil, puffing along with an inefficient engine and with a body leaking vast amount of energy. Each drop wasted drives higher the price of future oil purchases...<sup>2</sup>

Efforts to accelerate conservation can have a number of strategic effects. In addition to reducing imported energy sources, the following is possible:

- Reduced energy demand decreases pressure on centralized systems and reduces the need for costly new construction of these facilities.
- Reduced energy demand can also reduce strategic material demand.
- Reduced capital requirements for energy facility construction can be channeled to other areas of the economy.
- Inflation can be reduced, affecting the entire economy.

The director of the Joint Economic Committee's energy subcommittee has stated:

By the end of the decade, conservation savings have the potential of wiping out the majority of our oil imports, while synfuels will be producing no more than a million barrels a day...Why then, has so little been done? For one thing, today's energy supplies are heavily subsidized while conservation is not. Conservation will yield enormous rewards and can do so fairly quickly, but only in modest and multiple increments, after hard decisions frequently best made without fanfare, with political pressure against institutional lethargy and with thousands of public and private investments.<sup>3</sup>

### Energy Conservation Targets (3.2-2)

#### Residences

Residential use of energy accounts for twenty percent of energy consumption in the United States.<sup>4</sup> Increasing energy cost and uncertain future energy supplies have spurred a reassessment of the energy intensive building designs of the 1960s and 1970s. A combination of retrofit, technology change, creative design, and economic incentives will all contribute to the construction of more energy-efficient buildings. Table 3.2-1 provides a percentage breakdown by use of average U.S. residential energy consumption.

Table 3.2-1<sup>5</sup>

#### RESIDENTIAL ENERGY CONSUMPTION, BY USE

<u>Use</u>	<u>Percent</u>
Space Heating	53
Hot Water	14
Cooling	5
Air Conditioning	7
<u>Other</u>	<u>21</u>
TOTAL	100

Many of the conservation efforts that have been proposed are not in the best interest of long-range effectiveness. The energy vulnerability of the United States is actually increased by "quick-fix" conservation efforts when those efforts

perpetuate the use of existing energy intensive technologies and diminish the level of investment in energy-efficient systems and approaches. The most effective energy policy would encourage rapid turnover of inefficient machinery and replacement of high energy consuming buildings and equipment.<sup>6</sup>

Short of structure replacement, many buildings can be "tightened up" or retrofit to ensure more efficient energy utilization. Retrofit alternatives include ceiling and wall insulation, storm windows and doors, heat pumps, weatherstripping, caulking, day-night thermostats, and pilotless natural gas furnaces. New buildings incorporating these features as well as passive solar designs, natural cooling capability, more efficient space conditioning systems and more efficient use of mass and materials offer even greater conservation opportunities.

Additional conservation opportunities also exist in the residential sector by the use of more efficient appliances and machinery including refrigerators, water heaters, and other large energy-consuming devices. Energy savings from such equipment will be realized chiefly through better engineering and construction standards promoted by regulation, although market forces will continue to be a factor as consumer preferences respond to increasing energy costs.

### Industry

Industry accounts for 39.5 percent of total U.S. energy consumption.<sup>7</sup> The industrial sector has made the greatest progress in energy conservation. Decreased profits tend to generate interest in searching for cost-effective methods to save energy through improved maintenance procedures, recycling, waste heat recovery, and energy-efficient machinery.

Industrial conservation programs have demonstrated a significant degree of success for major U.S. companies such as Lockheed, which reduce 59 percent of its energy demand between 1972-77 in its Los Angeles factory complex at little or no capital expense. In its U.S. refineries, Exxon reduced energy use 21 percent during this same period—80 percent of this saving was developed with little or no capital invested. The savings are equivalent for this one corporation of 11.3 million barrels of oil per year.<sup>8</sup>

A much-needed increase in industrial conservation programs may occur as a result of new federal laws, such as the ten percent business energy investment tax credit established by the 1978 National Energy Act. Tax credits and faster depreciation schedules are considered to be major inducements for industrial conservation efforts. However, the Internal Revenue Service (IRS) has only recently issued proposed rules for technologies qualifying for the credit. A recent industrial analysis of the rules state, "in a major setback for users IRS failed to expand the list of specifically defined energy property that qualifies for the tax credits, although the 1978 law encouraged such a move by the Secretary of Treasury."<sup>9</sup>



Notwithstanding disincentives, industrial conservation efforts continue to provide a major "source" of energy supply, reducing overall demand and the need for imported energy.

### Transportation

Transportation accounts for 26 percent of the total United States energy consumption, with the automobile accounting for over half that amount. The dispersed settlement patterns characteristic of the U.S. indicate that the automobile will remain a focal point for conservation efforts for some time. The most viable conservation targets can be met with reduced driving speeds and increased automobile efficiency. Some conservation might be attained through the development of efficient, flexible mass transit systems and lesser, related efforts such as ride-sharing and variable work schedules.

The major gains in automobile efficiency has been the result of weight reduction and the importation of foreign technology. Yergin points out that "substantial technological innovation is needed in materials, engine and design; and this kind of innovation, as opposed to styling, has not been a major priority for the industry or its suppliers. Massive capital investment is needed over a decade for the four U.S. automotive companies, which will increase vehicle costs."<sup>10</sup>

Such investment might be directed toward the development of radically different smaller cars including two passenger vehicles. Statistics show these would suffice for three-fourths of all trips. The redesign of existing large cars for five-year production runs, to hand on to rapidly dwindling markets, is extremely costly compared to the one-step introduction of extremely efficient cars.<sup>11</sup> The technology to build an 80 mpg auto fleet is nearly ready for commercialization.<sup>12</sup> Table 3.2-2 represents future fleet possibilities available in the near future, with appropriate investment.

Table 3.2-2<sup>13</sup>

### FUTURE FLEET POSSIBILITIES

Vehicle Class	Vehicle Test Weight (lb)	Cruise hp 55 mph	Extra hp, 55 mph, 5% grade	Acceleration power (hp)	Average Engine hp	cylinder	Projected mpg	
2 Passenger	Available Now	2250	14.8	--	--	--	--	
	Available 1982	1500	9.0	11.0	16.9	23	2	110
	Test Demonstration	1350	7.2	7.7	12.2	18	2	140
4 Passenger	Available Now	2600	13.0	--	--	--	--	
	Available 1982	2500	9.3	14.7	21.4	32.5	3	78
	Test Demonstration	1400	7.3	10.3	15.4	27.1	3	93
5-6 Passenger & light truck	Available Now	2500	13.5	--	--	--	--	
	Available 1982	2500	12.1	13.3	23.9	47.4	4	58
	Test Demonstration	1750	3.1	12.3	18.6	35.9	3	70

Other possibilities in this area include driver efficiency training programs, automobile registration fees based on efficiency and weight, regulation of fuel prices, and increased fuel taxes.

### Conservation Incentives (3.2-3)

The federal government's response to the 1973-1974 oil embargo was to set an objective of achieving energy independence by decreasing oil imports while expanding the development of domestic fuels. National incentives for energy conservation are represented by passage of the following legislative measures:

- Energy Policy and Conservation Act (1975)
  - a. set automobile fuel economy standards which established average fleet mileage requirements
  - b. set efficiency targets for large appliances
  - c. set targets for industrial-energy conservation
  - d. provided assistance to states for development of state energy plans
- Energy Conservation and Production Act (1976)
  - a. set energy conservation standards for new buildings, Building Efficiency Performance Standards (BEPS)
  - b. establish a low-income weatherization programs
- National Energy Extension Service Act (1977)

Each state is responsible for developing and implementing a comprehensive program for direct, local, and personalized assistance to encourage small energy consumers to adopt techniques and technologies that save energy.

  - a. ten pilot states were funded initially for 1978-79 to deliver programs through existing agencies.
  - b. all 50 states and trust territories implement programs in 1980-82
- National Energy Conservation Policy Act (1978)
  - a. established the Residential Conservation Service (RCS) through which utilities will conduct energy audits and arrange for financing and installation of insulation and other conservation devices or measures.
  - b. extended the low-income weatherization program to 1980
  - c. established the Schools and Hospitals Program
  - d. set appliance efficiency standards
  - e. established home improvement loans for energy conservation

• Public Utility Regulatory Policies Act (1978)

- a. required that retail regulatory policies for electric utilities be reviewed by state regulatory commissions to consider and determine ratemaking standards (including lifeline rates) that would encourage conservation
- b. allowed for more equitable rates of return for small cogeneration and small hydroelectric facilities' sales to utilities
- c. encouraged conservation of energy supplied by gas utilities, the optimization of the efficiency of use of facilities and resources by gas utility systems, and provided for equitable rates to gas consumers of natural gas

• Windfall Profit Tax Act (1980)

- a. continued price decontrols (which has the effect of increasing conservation as the market adjusts to actual energy costs)
- b. expanded the categories eligible for federal tax credit
- c. established the Energy Investment Tax Credit to encourage commercial conservation investment

• Energy Security Act (Title V) (1980)

- a. established a Federal Solar and Conservation Bank through which approximately 80 percent of the funds allocated were earmarked by increasing incentives for the purchase and installation of conservation equipment through:
  1. principal reduction on loans
  2. direct grants to consumers
  3. payments to banks for pre-paid interest
- b. removed the ban, instituted by previous legislation, on direct utility financing of energy conservation measures and alternative energy equipment

The Energy Management Partnership Act, if enacted, would allocate more federal money to the states for conservation planning with the objective of consolidating existing programs and promoting state and regional planning.

Research, Education and Regulation (3.2-4)

Growth in privately-initiated and federally-sponsored energy conservation research and development has not grown as quickly as research and development programs in energy production.

Government-sponsored research could address obstacles such as consumptive behavioral patterns, structural and institutional barriers, and legal restraints to maximizing conservation. Non-economic factors affecting the final selection of a product also need to be analyzed to determine factors in consumer decisions to effect conservation.

Table 3.2-3 summarizes the opportunities for technological research which could be conducted in support of energy conservation. Clearly the tasks are as demanding as those in any other area of energy development.

Table 3.2-3<sup>14</sup>

OPPORTUNITIES FOR TECHNOLOGICAL RESEARCH  
AND DEVELOPMENT FOR ENERGY CONSERVATION

	Buildings and Appliances	Transportation	Industry
Basic studies	Properties of materials Automatic control technology	Materials properties, e.g. strength-to weight Thermodynamics of internal/ external combustion engines Chemical energy storage Automatic control technology	Materials properties at high temperatures Characteristics of industrial combustion Heat transfer and recovery methods Automatic control technology
Near-term energy-use patterns	Automatic set-back thermostats Pilot/burner retrofit	Specific data on factors that influence fuel economy of existing cars	Improved methods for energy monitoring and house-keeping
Intermediate-term retrofit	Reinsulation methodologies Solar water heating and passive design  Metering for time-dependent utility pricing  Automatic ventilation control for building and appliances (e.g., clothes dryers)	Improved power-to-weight ratios, as well as interior volume-to-weight ratio  Instrumentation to provide driver with real-time data on fuel efficiency Improved intermodal freight and passenger terminals Improved traffic control	Process retrofit technologies Improved methods for scrubbing Cogeneration of heat and electricity Automated monitoring of energy performance  Low-temperature heat utilization
Long-term technologies	High-performance electric and heat-driven heat pumps Solar space cooling Sophisticated appliance controls and integrated appliance design More sophisticated design of buildings to provide desired amenities at low energy demand	New motors Improved aerodynamic design for cars, trucks New primary energy sources (liquid, electric) Improved intermodal transfer technology Technology for improved efficiency in air transport	Basic new processes that reduce overall requirements for energy and other resources (e.g., recycling, durability) per unit output Modification of material properties to enable replacement of energy-intensive materials with less energy-intensive material in specific applications

The automobile efficiency standards established after the oil embargo are a good example of a major regulatory program. The Ford Foundation report suggests "...that the standard may reduce long-run gasoline consumption by about 26 percent from what it would have been otherwise. New car efficiency is projected to increase by 47 percent, and vehicle miles by 8.8 percent."<sup>15</sup> In this case the regulations spearheaded market changes that had been traditionally resisted. Since there is a tendency for regulations to become entrenched and solidified after adoption, maintaining flexibility merits close attention by policymakers. Energy efficiency regulations may be best approached incrementally and be modified as technologies and methodologies change.

It has been suggested that rate reform is necessary to eliminate distortion and the restricted pursuits of energy conservation.<sup>16</sup> Current energy prices do not represent the numerous factors affecting actual costs of energy production. For example, if the price charged for using electricity reflected actual production costs, consumer rates would reflect the marginal operating and fuel costs associated with peak capacity generation. Some experts argue that there can be no justification for declining block and discounts to volume users in a period of shrinking energy supplies.

One relentlessly rising fuel consumption has had an institutional rationale. A dollar invested in facilities to produce more energy makes energy available to the producer, who then sells it for profit. Although the same dollar invested in conserved energy (which would otherwise be wasted) is energy that the energy producer had already counted as sold; the company, for whom a dollar burned is a dollar earned, is generally unenthusiastic about "returned merchandise." If a utility sells a billion kilowatt hours this year, and ten years from now is still selling a billion kilowatt hours, its dividend-conscious stockholders will take little satisfaction in the greater efficiency and benefits of the future billion. Corporate officers cannot relish the prospect of informing stockholders and lending institutions that their company has completed a successful transition into a non-growth economy.<sup>17</sup>

National conservation programs were recently evaluated by the Office of Technology Assessment, which suggests that they are fraught with problems at a time of increasing need and expectation.<sup>18</sup> The report calls for rigorously defined conservation goals to supplement the Committee on Nuclear and Alternative Energy System's (CONAES) scenarios that are currently used to set energy-saving levels:

It is necessary to define what actually has to happen for the nation to meet the goals and what DOE's role must be to ensure success. National security considerations may make...conservation implementation even more imperative than it appeared at the time that goals were set.<sup>19</sup>

The nation's conservation programs could further detail goals and objectives by identifying:

- materials necessary to achieve the desired results
- anticipated technological changes
- resource projection and location
- estimated time requirements for removal of market barriers
- anticipated time requirements for turnover of capital stock, and
- necessary capital investment

Long-term objectives are also necessary for both program implementation and program evaluation. Evaluation of energy conservation programs allows for continuous assessment of strategies and their degree of coordination relative to national objectives.

State programs vary in scope and intensity. Energy demand growth has been reduced in California by means of a variety of conservation actions. California utility demand forecasts predicted that the electrical peak demand would be in excess of 41,000 MW in 1979; the actual 1979 demand was 6,000 MW less.<sup>20</sup> California has set state conservation standards for appliance efficiency, new residential and non-residential buildings, automobile efficiency, and utility load management. California is carefully monitoring federal policy formation to ensure that the standards adopted at the national level do not conflict with more stringent state standards.<sup>21</sup>

### Projections (3.2-5)

Projections can be illustrative of potential trends and relationships within the total energy system. The Committee of Nuclear and Alternative Energy Systems (CONAES) report is based upon assumptions of energy price, GNP growth, population growth, conservation, energy resource/power production, and policy/regulatory conditions. Table 3.2-4 and Figure 3.2-1 represent energy demand projections under five energy conservation policy.<sup>22</sup> These show valuable indicators of the possible range in energy-consumption, by sector, as a result of specific policy direction.<sup>23</sup> Table 3.2-5 summarizes U.S. energy consumption and indicates potential savings across residential, commercial, industrial and transportation sectors.



## SCENARIOS OF ENERGY DEMAND: TOTALS

Scenario <sup>a</sup>	Average Delivered Energy Price in 2010 as Multiple of Average 1975 Price (1975 dollars) <sup>b</sup>	Average Annual GNP Growth Rate (percent)	Energy Conservation Policy	Energy Consumption (quads)					Primary consumption <sup>d</sup>
				Buildings	Industry	Transportation	Total	Losses <sup>c</sup>	
Actual 1975	--		--	16	21	17	54	17	71
A* (2010)	4	2	Very aggressive, deliberately arrived at reduced demand requiring some life-style changes	6	26	10	42	16	58
A (2010)	4	2	Aggressive; aimed at maximum efficiency plus minor life-style changes	10	28	14	52	22	74
B (2010)	2	2	Moderate; slowly incorporates more measures to increase efficiency	13	33	20	66	28	94
B (2010)	2	3	Same as B, but 3 percent average annual GNP growth	17	46	27	90	44	134
C <sup>e</sup> (2010)	1	2	Unchanged; present policies continue	20	39	26	85	51	130

<sup>a</sup> Scenario D is not included in this table; its price assumption (a one-third decrease by 2010) appears implausible.

<sup>b</sup> Overall average; assumptions by specific fuel type were made reflecting parity and supply; price increases were assumed to occur linearly over time.

<sup>c</sup> Losses include those due to extraction, refining, conversion, transmission, and distribution. Electricity is converted at 10,500 Btu/kWh; coal is converted to synthetic liquids and gases at 68 percent efficiency.

<sup>d</sup> These totals include only marketed energy. Active solar systems provide additional energy to the buildings and industrial sectors in each scenario. Total energy consumption values are 63, 77, 96, and 137 quads in scenarios A, A\*, B, and C, respectively.

<sup>e</sup> The Demand and Conservation Panel did not develop a scenario combining the assumptions of unchanging price and 3 percent average GNP growth. If scenario B is used as an approximate indicator, such an assumption would entail a primary energy demand of about 175 quads.



Figure 3.2-1<sup>25</sup>

DEMAND AND CONSERVATION PANEL PROJECTIONS  
OF TOTAL PRIMARY ENERGY USE TO THE YEAR 2010 (QUADS)

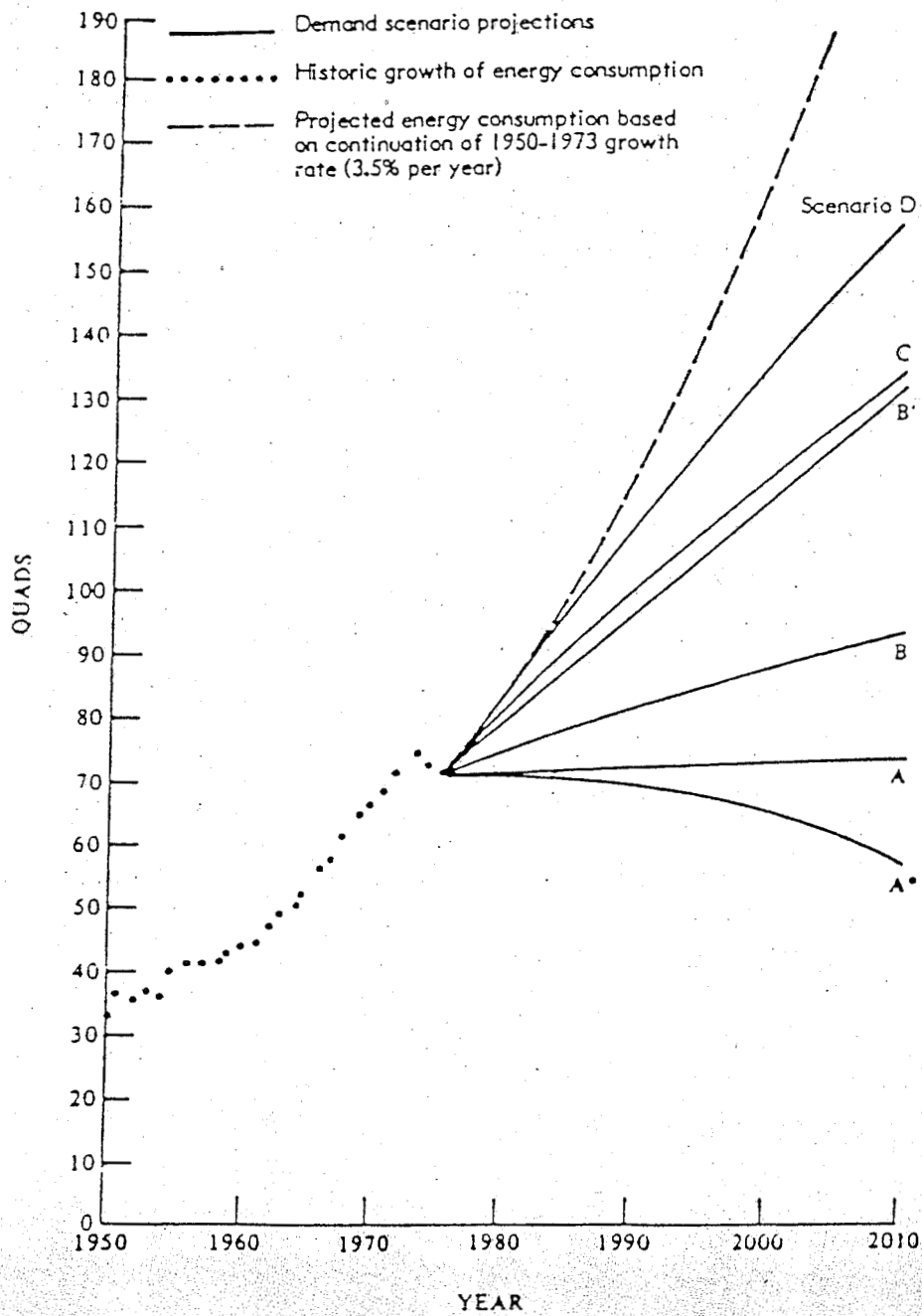


Table 3.2-5<sup>26</sup>U.S. ENERGY CONSUMPTION (QUADS)

	<u>Residential/ Commercial</u>	<u>Industrial</u>	<u>Transportation</u>	<u>Total</u>
1979 Consumption	29.5	28.9	19.8	78.2
1990 No Change Path (Scenario C)	23.6	69.5	26.9	120
1990 Possible (Scenario B)	18.4	58.6	23.0	100
% Savings	22%	15.7%	14.5%	20%
1990 Possible (Scenario A)	14.1	43.6	16.5	80
% Savings	40.3%	37.3%	38.2%	40%

The Department of Energy has adopted the projections of the CONAES report as the basis for national energy conservation objectives. The energy savings depicted in Scenario A have essentially become the conservation goals for the United States. There is, however, no direct correlation between the goals and the current programs identified in DOE's Energy Conservation Program Summary Document.<sup>27</sup>

End-use estimates of potential energy reduction, costs, and time requirements are difficult to obtain. The historical record does not give insight into ways to reduce energy demand. There is no repository of information on the technological advancements, methodologies, and achievement levels necessary to reduce energy consumption although certain local efforts have produced remarkable results. Energy conservation is a new frontier for which the record is just now being established.

A potential role of government is to eliminate current disincentives for implementing the most appropriate conservation technology. The choice of technology is a decision ultimately housed in the private sector. The market is responsive to the needs and desires of millions of individual decision-makers.

...in a time in which many Americans did not believe that an energy crisis existed or that, if it did, it was the result of conspiracy among the oil companies and in which polls revealed that more than half of the American public did not know that we imported any oil from abroad, home insulation sales soared. Price was talking to the consumer when administration policy, television programs, and newspaper articles had failed to convince.<sup>28</sup>

As the marginal costs of energy rise in the coming years, it will become more and more profitable to make an investment "to save a Btu than to produce an additional one."<sup>29</sup> The CONAES report projected delivered energy prices to the year 2010. The results indicate a wide range of energy prices, which in turn have a wide range of effects on consumption levels. The report stresses the importance of allowing sufficient market-adjustment time after introduction of increased energy prices or decreased supplies in order to avoid major economic disruption.<sup>30</sup>

#### Time Requirements (3.2-6)

Estimates of the time required to reach certain levels of energy efficiency vary, yet they share as a common strategy the need for long-term energy conservation planning. The CONAES report projects that following approximations of time required for replacement of non-energy efficient capital stock:

Housing	50+ years
Industrial plants	20-50 years
Automobile	10 years

It is anticipated that the rate of turnover will be expedited by increasing energy prices.

#### Conclusions: Conservation (3.2-7)

As the arguments and data presented for conservation indicate, strategies for energy conservation have both an immediate gain in reduced imports, economic savings, and reduced vulnerability, and a long-range gain, in laying the foundation for dispersed and decentralized supply development.

Conservation is a legitimate energy source, in some ways superior to the production technologies. Nevertheless, anything more than quickfix efforts will demand a significant commitment of research and development resources. As with the production technologies, meaningful energy conservation, that is, energy management, will entail a good deal of sophistication and innovation.

In line with the need for innovative approaches to the energy problem is the research of Roger Sant at the Mellon Institute. Recognizing that a different perspective on the situation is needed, he and his colleagues at the Energy Productivity Center have developed the "least-cost strategy," a perspective which concentrates on the end result of energy use and how best to provide individual consumers with those benefits at the least possible cost. He explains:

The conventional import context in which the energy problem has been examined concentrates on the numbers of barrels of oil that can be produced or 'saved' through new production or conservation. Within this framework, the competing elements include various fuels—oil, coal, natural gas, etc.—and various methods of 'saving energy'—lower speeds on the highways, colder homes in the winter and warmer homes

in the summer, etc. But production and conservation of a given number of barrels of oil or other quantities of energy only partially addresses the function of energy in our economy and lives. A thriving economy and a materially rewarding life are dependent not on the given quantity of energy consumed, but on the services or benefits that are derived from that consumption.<sup>31</sup>

The least-cost energy strategy assumes a traditional free market system in which traditional and alternative energy technologies face stiff competition to be the most energy-efficient technologies. Those that provide the same or better "service" at the least cost would prevail. To test this assumption, several analyses were performed to determine the kind of energy "savings" that could have taken place prior to 1978. The results indicated that the cost of energy services during 1968-1978 could have been reduced by seventeen percent with no curtailment of services.<sup>32</sup>

The study concluded:

Although the least-cost strategy might not result in the 60 percent improvement in energy efficiency by 2010 that the CONAES study indicated is technically possible, or even the 32 percent that our analysis indicates is economically achievable in a much shorter period, the evidence we have provided demonstrates that there is ample competition to hold consumer costs to manageable levels for the required level of energy services.

...A wave of optimism--and commitment--is beginning to emerge from many quarters: these changes are possible, desirable and necessary. Perspectives have and will continue to change rapidly. When coupled with ingenuity, new technology and improved management, these changes can be powerful enough to master the energy problem. In fact, seen in this perspective, the problem is transformed into an opportunity--increased employment, new markets, an enhanced environment, a more secure energy future and most important, less onerous levels of energy service costs. We are definitely not stuck with our old attitudes about energy and energy conservation. Our analysis to date shows we can move to higher levels of productivity through a more competitive, consumer-oriented energy policy.<sup>33</sup>

### Load Management and Energy Storage (3.3)

At present, the demand for instantaneous energy is met by fuel reserves, the most convenient form of large-scale energy storage. As pointed out by the Electric Power Research Institute (EPRI), "oil and gas stand out as the preferred fuels for storage because of their high energy density and their ease of transport and combustion. Utilities, in particular, have come to rely on them to run the power plants that are started up and shut down each day to meet peaks of demand for electricity."<sup>34</sup>

This reliance on fossil fuels is likely to change as fuel scarcities prevent the use of key fuels, and as the high capital costs of building "peaking" power plants are outweighed by more convenient and less costly options to utilities. These options include conservation, load management practices, fuel storage and energy storage technologies and other measures to reduce costly peak demands. As the EPRI Journal explains:

Starting with the supply side (of the integrated energy system), direct and indirect storage of electricity from coal and nuclear baseload plants can displace the consumption of oil and gas in peaking and intermediate (cycling) power plants. Present estimates are that fully implemented utility storage systems could supply 1.5-2.5 percent of U.S. electric energy by the year 2000, providing up to 15 percent of peak load demand from stored coal and nuclear in some regions. For each gigawatt (1,000 megawatts is equivalent to the nuclear or coal power plant) of energy storage plant in operation, two to three million barrels a year of petroleum could be saved. The total savings for the United States at the turn of the century could be as high as 150-300 million barrels a year."<sup>35</sup>

#### Load Management (3.3-1)

Some estimates of the overall potential energy savings for load management and energy storage are considerably higher than that referred to by EPRI. It is theoretically possible to replace one-fourth or more of the existing power plants in the U.S. with "alternative power" in the form of stored energy, and properly managed loads. Although quantified estimates are not available, the theoretical possibilities indicate that millions of kilowatts of potential installed capacity can be deferred, and billions of dollars of investment in electrical and other energy facilities can be channeled into other potential economic areas.

Under the Public Utility Regulatory Policies Act, (PURPA) federal standards were established for the following utility rate and load management practices.

1. Rates charged by electric utilities "shall be designed, to the maximum extent practicable, to reflect the costs of providing electric service to such class..."



2. Declining block rates are discouraged, e.g. rates that encourage excessive use by minimizing unit costs to large consumers in "declining blocks."
3. "Time of Day" rates are encouraged, e.g. rates that discourage consumption during peak demand periods.
4. Seasonal rates are encouraged, to reflect the "costs of providing service to such class of consumers at different seasons of the year to the extent that such costs vary seasonally for such utility."
5. Interruptible rates, e.g. discounted rates for industrial and commercial customers that can be interrupted during peak load periods, are required.
6. Load management techniques to reduce peak demands (under the review of state regulatory commissions) are required, with the determination that they be:
  - a. practicable and cost-effective
  - b. reliable
  - c. provide management advantages to the utility.<sup>36</sup>

The hallmark federal law additionally requires that load management techniques shall be determined by state regulatory commissions or unregulated public utilities, in accordance with these guidelines:

1. The technique must be likely to reduce the utility's maximum kilowatt demand.
2. The long-run cost savings to the utility must be likely to be more with load management, than without the application of load management.<sup>37</sup>

At present much is known about the peak demand periods of the nation's utilities, but little is known about load management approaches in a "real world" sense. How the various technologies for controlling consumer's loads and integration of these techniques with utility management practices remains to be determined.

Time-of-day rates and load management practices are frequently directed towards residential consumers of electricity in order to reduce the use of certain energy-intensive appliances, such as hot water heaters or air conditioners. Hot water heaters are a prime target for peak reduction practices, since their "coincident peak demand" is quite high. A Wisconsin utility survey found that individual water heaters average 4,500 watts in electrical demand.<sup>38</sup> Nationwide surveys have found that the average coincident peak demand falls in the range of .8 to 1.5 kw in a given utility system. This occurs because all hot water heaters are not running at the same time. On the average, about twenty percent are in use during peak periods.

Translated into power plant terms, one household appliance represents about 4.5 kilowatts of inferred capacity. Or in system terms, when twenty percent of these units are operating during peak periods, the capacity value of each unit is about one kilowatt. If the utility were to build new peaking power plants to meet the demand generated by water heaters, the cost per house would be the equivalent of \$500 to \$1,000 (installed costs, not counting fuel). However, by using commercially available thermal storage technologies in conjunction with load management devices to reduce the use of these appliances during peak periods, the utility would save the capital cost of building a new power plant. In fact, the conservation alternative is only \$200 per house, which reflects the total cost of reducing the load and paying for additional heat storage. Translated in terms of thousands of consumers, the savings are potentially enormous. However, in order to credit the customer with a peak-reduction rate (in conjunction with using a timer on a water heater), the utility must be able to verify that the appliance is not capable of being used during a peak period. The central issue then becomes the actual control over energy use within the household.

According to two officials of the Wisconsin Public Service Commission, the answer may be time-of-day rates:

An appropriate time-to-use rate alternative should be a temperature-sensitive rate. Then, each potential load management customer could achieve the same or regular savings under a time-of-use rate he should achieve under load management (LM) during peak demands. Moreover, he could install storage devices and timers. He would not try to cheat himself, since the conservation strategy would not reside with his imagination, not in some distant utility boardroom. The answer....lies in who owns and activates the LM controls. If the controls are activated by the utility, there is a built-in incentive for the customer to take the benefits and avoid the effects, if that is possible. If the customer activates the controls, the incentive is to maximize his benefits through the control of his appliances. The customer's pattern will depend on the time-differentiated price of electricity.<sup>39</sup>

A first step to load management is load research to determine a more precise understanding of demand. This is now being conducted by the nation's utilities. The voluminous data developed by utilities can be used to shape load management programs. A recent Tennessee Valley Authority report on load research points out that "most of the nation's 90 million electric customers have their electric meter read once each month and those meter readings comprise an enormous data base which is maintained for many years under most state regulations. As large as that data base may seem, however, it only begins to scratch the surface in terms of telling how people use their electricity."<sup>40</sup>

New techniques for load research such as remote monitoring of customers' use of electricity, and feedback capability through microprocessor-coupled



communications systems, offer utilities significant load control information, and potentially, load management options. New technologies for load management include remote monitoring and control of water heaters, air conditioners, and a variety of thermal storage devices to allow for cyclic operation of key appliances, including cooling devices.

Examples of innovative load management programs are actively being pursued by the Southern California Edison Company, a major private utility which serves Los Angeles and Southern California. One program, called "Demand Subscription Service" incorporates elements of load cycling and time-of-day rates. A demand-limiting device is installed at the residence (connected to the meter), which is set to disconnect electrical service if the demand for power is exceeded during a system peak or other period of capacity shortage. Once disconnected, the customer can reduce the residential electrical load under the present limit for service, then manually switch on the device. The system can be operated automatically by the utility's load controllers to reduce peak demands. The utility will place 2,000 of these units on residences during 1980 and 1981.<sup>41</sup>

Southern California Edison (SCE) has also established a new energy co-operative concept for load management for larger commercial customers (with an average of five megawatts of demand).

The first modern co-op was formed in 1979 in Orange County in Southern California. The Irvine Company, Fluor, Pacific Mutual Life Insurance and the South Coast Shopping Plaza formed the Orange County Energy Cooperative Association. For a monthly rebate of \$120,000 (i.e., approximately \$1.5 million per year) the co-op agrees to shave four MW off peak load whenever SCE requests it to do so. In practice the co-op has 30 minutes to reduce load to a fourteen MW maximum.

The initial capital investment saving to SCE under this arrangement is approximately \$4 million (based on an estimated \$1,000 per installed capacity). In addition, since peak load power is most often generated from standby reserves of oil and gas, the operating savings are also substantial and becoming more so as fuel costs escalate.

Other co-ops are in the formation stage by California's Pacific Gas and Electric Company (PGE) and in Nebraska. In areas where reserve margins are high, such as Dallas, Texas, co-ops are not being encouraged by the utilities. This situation, however, could change as large capital investments become ever more costly. Load management using electrical co-ops is being promoted and supported by the Department of Energy.<sup>42</sup>

### Energy Storage (3.3-2)

A number of energy storage methods currently available or on the horizon would enable electrical energy generated in off-peak hours to be stored for use during high demand periods. The various energy storage technologies could also be utilized to harness the energy produced by alternative energy systems that are often tied to the unpredictable environment. This energy can be stored either as heat, electricity or kinetic energy.

Thermal energy required for storage can be derived from various sources, such as solar heat, winter cold, power plant waste heat, and industrial steam. In the case of solar heat, heat can be captured by collectors in the summer and stored. It can then be extracted for winter use when the demand for space heat peaks. The hot steam that is usually dissipated to the environment by electrical generation facilities can be used for district heating. This winter heating capacity can be increased by storing the heat energy from summer generation. In addition, this would reduce the thermal pollution generated by power plants and reduce the need for peaking units to meet exceptional winter heating demands.<sup>43</sup>

Aquifers are being considered for thermal energy storage. The ground water stored in aquifers is subject to geothermal radiation that usually maintains the aquifers' temperature about equal to the average annual surface temperature. This natural warming action provides a positive temperature differential for heating in the winter when ambient air temperatures are cooler and for cooling in the summer when the surface temperatures are warmer.<sup>44</sup>

This underground storage resource can be exploited by the use of a simple heat pump or heat exchanger. The basic mechanical concept for either heating or cooling is the same. A gaseous fluid with a low boiling temperature like ammonia or freon is cooled by lower pressures to a gaseous state and pumped into a higher temperature aquifer. This cool low pressure fluid absorbs the heat from the environment and then upon condensation it is circulated to warm a cooler environment. To remove the cooler temperatures from the aquifers during the summer, the process is reversed.<sup>45</sup>

The potential for using a heat exchange system to tap the energy storage capacity of aquifers is large. Heat pumps installed in aquifers are operating with a performance co-efficient greater than 4.0. It is estimated by Dr. Jay H. Lehr, of the National Water Well Association, that with a consumption rate of ten gallons per minute for domestic energy demands, that at least 70 percent of the surface of the country can be developed while commercial systems with an output of over ten million Btus can be located over 25 percent of the United States. Studies are now being conducted to determine the actual performance potentials of aquifers and the concept of man-made aquifers.<sup>46</sup>

Energy can also be chemically stores in an electrical system. New battery development offers a non-polluting, compact, and modular unit that can fit the needs of most energy storage interests. Conventional lead-acid batteries cannot withstand the constant cycling between being fully charged and discharged that is essential in either utility or automobile use. The price of heavy-duty design, lead-acid batteries is prohibitively high for general use.

New research efforts are designed to develop high temperature battery technology. High temperature batteries hold the promise of improved performance at a lower cost. Lithium-sulfur and sodium-sulfur high temperature batteries are receiving most attention. The sodium-sulfur cell operates at temperatures near 350°C using molten sodium and sulfur electrodes. The sodium-sulfur battery uses a solid ceramic beta alumina material for its electrolyte. Lithium-sulfur batteries

use a molten salt, such as a lithium chloride-potassium chloride eutectic mixture as their electrolyte. The lithium-sulfur battery functions at a temperature range of 357°C to 400°C and theoretically has a greater performance potential than sodium-sulfur cells. In both batteries there are problems with containment of the electrodes, the location of inexpensive and corrosion-resistant construction materials, and sealing at high temperatures.<sup>47</sup> Until these difficulties are mitigated, sodium-sulfur and lithium-sulfur batteries will not be commercial.

Recently, NASA Lewis Research Center in Cleveland, Ohio, conducted a joint Department of Energy and NASA funded project to develop reduction-oxidation battery technology. This battery system, called Redox, promises to provide an inexpensive, long-term, and reliable method of storing electricity. Redox batteries are currently being developed for use in the kilowatt range, but they could eventually be scaled up for use in utility load leveling.

The Redox system consists of a "stack" or combination of cells that takes advantage of the valence change in the reduction-oxidation process. Chromium chloride and iron chloride (reactant fluids) are pumped through the series of cells.

There are numerous advantages to the Redox battery. These include the basic simplicity of the system that allows for extended life and reliability. Also, low operation pressures (ten psi) and its functioning at ambient temperatures, enable the battery to use inexpensive carbon electrodes and other low cost construction materials. NASA also notes that an important advantage of the Redox system is in the flexibility in sizing the stack and reactant fluid storage tanks independently to achieve the most efficient system characteristics.<sup>48</sup>

Companies like Gulf, Western, and General Motors are quickly approaching a point where they and commercially produce a battery that economically facilitates demand load-leveling and will even power electric vehicles in the near future.

Electrical energy can be stored by means other than batteries, for example, superconducting magnets. In a typical electromagnet, the resistance of the magnet's winding causes power losses and power must be constantly applied in order to maintain the field. If this winding lacks resistance (superconducting), then once the desired magnetic field is established, no further energy input is needed and the original energy input is stored in the magnetic field. Up to 95 percent of the original electrical energy can be drawn off the magnet when needed.<sup>49</sup>

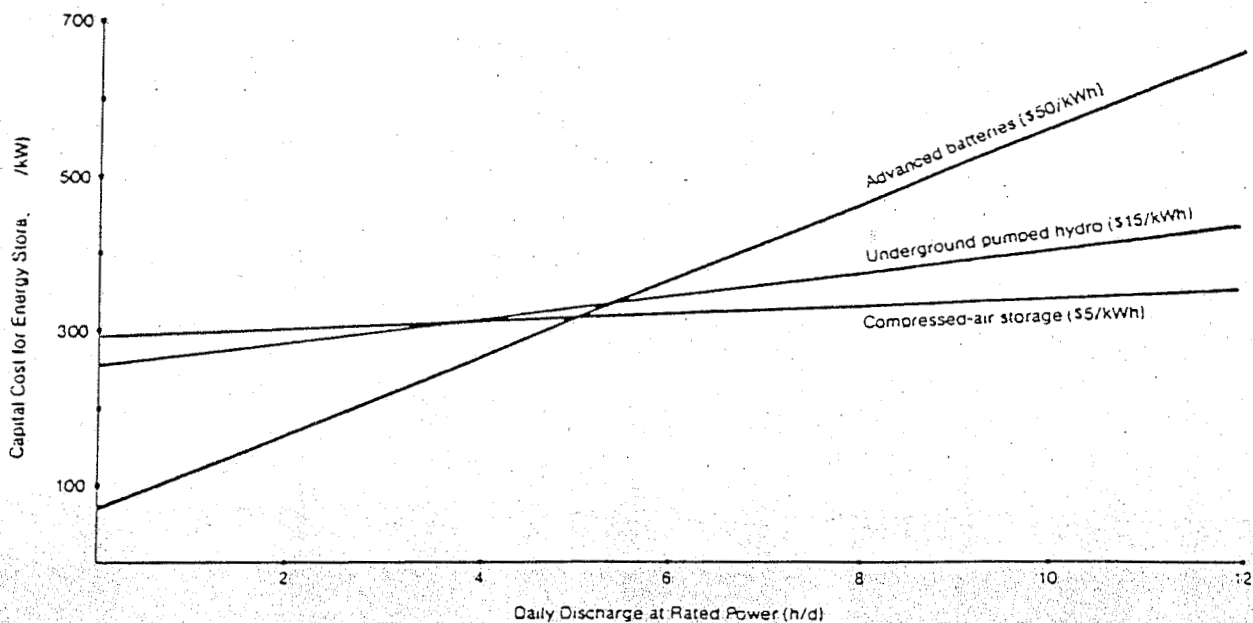
The University of Wisconsin at Madison and the Los Alamos Scientific Laboratory in New Mexico have determined that storing energy for utilities using superconductors, is only economical in the 1,000 to 10,000 megawatt-hour range. Superconducting storage facilities could be more easily located near demand centers if they were located underground. This would also minimize the possible impact of the magnetic field on the immediate environment. Magnetic storage is still in the research and demonstration stage until the technology is further refined.<sup>50</sup>

Compressed-air storage is also promising. In a conventional gas turbine, compressed air is mixed with fuel to generate mechanical power. About 60 percent of the energy produced by the turbine is needed to run the air compressor. To store compressed air, the compressor and turbine can be alternately connected and disconnected from the generator. During off-peak periods, only the compressor could be operated to compress air to be stores for use during times of exceptional demand. This compressed air can then operate a turbine during peak demand periods.<sup>56</sup>

Figure 3.3-1 compares the cost of three alternative utility storage technologies, advanced batteries, underground pumped storage, and compressed-air storage. These systems look increasingly promising when long periods of discharge (from storage) at full power levels are required. Many utilities look for discharge capability of eight to ten hours or more; for discharge periods of less than eight hours duration, battery systems look promising.

Figure 3.3-1<sup>57</sup>

COMPARISON OF ENERGY STORAGE TECHNOLOGIES

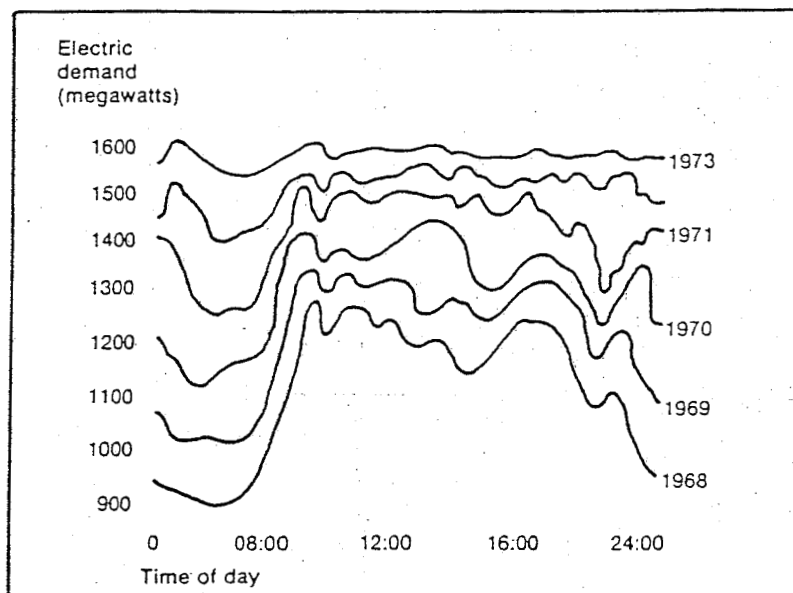


Currently a combination of load management and thermal storage is widely used in Europe. Load management in Germany was originally practiced during the Second World War, when automatic systems were developed to turn off night lighting during air raids. After the war, similar techniques were used to manage utility loads, and automatically turn off appliances during system peaks. In some parts of Germany today, as much as 25 percent of the total demand for electricity is met by electric storage heaters.<sup>58</sup>

The outstanding success of German utilities in perfecting load management technologies, combined with efficient energy-storing appliances, is shown in Figure 3.3-2.

Figure 3.3-2<sup>59</sup>

GERMAN LOAD MANAGEMENT: 1968-1973



The technologies available to European utilities are equally available in the United States, yet a few utilities have taken advantage of these basic energy-saving approaches. As the illustration shows, however, the twenty-four hour demand contour curve for this German utility has essentially been flattened by use of technology and special rates. Enormous capital savings are possible by deferring purchases of peaking power plants to meet demands during brief peak periods.<sup>60</sup>

The combination of load management technology and energy storage techniques is a fundamental element in any future energy policy to reduce overall demand on a major scale. As such, these technologies constitute important strategic energy developments, which can significantly reduce imports, an increase local system reliability.



## Cogeneration (3.4)

Cogeneration is the generation of electrical or mechanical power and useful heat from the same primary source of fuel.<sup>61</sup> This can be accomplished by using conventional steam turbines, combustion turbines, diesel engines, or other generation systems in what is known as "topping cycle," or as in the case of industrial waste heat, in a "bottoming cycle."<sup>62</sup> Figure 3.4-1 compares conventional electrical, process steam system, and cogeneration systems and illustrates how each operates.

The "topping cycle" uses various boiler-turbine configurations to generate electricity and then makes use of the valuable waste heat from steam for other processes.<sup>63</sup> Figure 3.4-2 illustrates this "topping cycle" in a cogeneration system. Table 3.4-1 describes the various characteristics of "topping cycle" cogeneration systems for gas turbines, diesel engines, and steam turbines.

One basic cogeneration system uses the back-pressure steam turbine. In a conventional steam turbine generator steam is exhausted from the turbine into a condenser at a very low temperature (about 100°F or 37.8°C) and at a pressure of around fifteen pounds per square inch gauged (psig). The waste heat from condensation is released to the environment at near ambient temperatures. Approximately 30 to 40 percent of the primary fuel can be converted to electricity. Unfortunately, the waste heat that is discharged from this system is not of useful quality for industrial processes.<sup>64</sup>

The back pressure turbine, however, facilitates the generation of electricity and useful steam from the same unit. In this boiler configuration fuel is burned to create steam in a high pressure boiler. The steam, typically in the 850 to 1,450 psig range, is used to drive a turbine that in turn produces electricity. Low pressure steam is exhausted from the turbine at a temperature and pressure suitable for industrial applications.<sup>65</sup>

The fuel savings derived from the combination facility are significant. The amount of primary fuel consumed beyond what is used to produce steam for the process use would be an estimated 4,500 Btu/kwh, or less than half the 10,000 Btu/kwh heat rate that is typical of central power facilities. Only ten to fifteen percent of the fuel consumed by a back pressure steam cogeneration unit is converted into electricity. Thus, this cogeneration arrangement can only produce a relatively small amount of by-product electricity for a given steam load.<sup>66</sup>

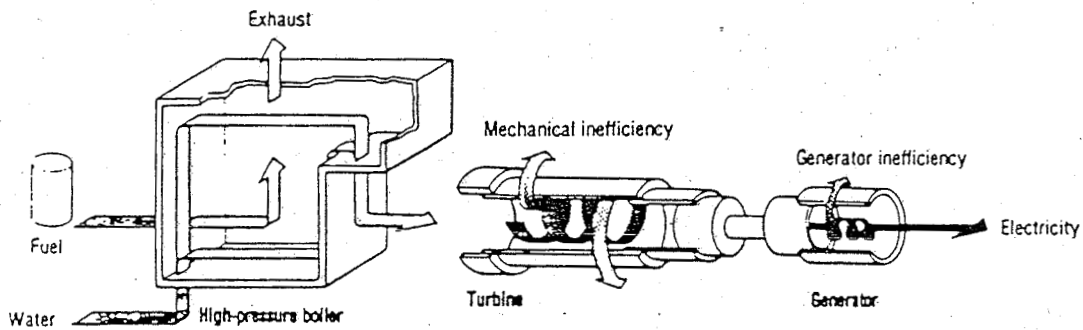
The reduction in effective electrical output characteristic of a back-pressure system can be almost totally mitigated with the use of a gas turbine-waste heat boiler or combined cycle unit. A directly fired gas turbine unit is fueled with a mixture of compressed air and distillate petroleum or compressed air and natural gas.<sup>67</sup> An indirectly fired gas turbine utilizes a heat exchanger between the fuel source and the turbine inlet, permitting the safe use of lower quality fuels without damaging the turbine blades. Both systems use the hot exhaust gas from the turbines to furnish the heat for steam production in a waste boiler. This high pressure steam can also be directly used in various industrial processes. In addition



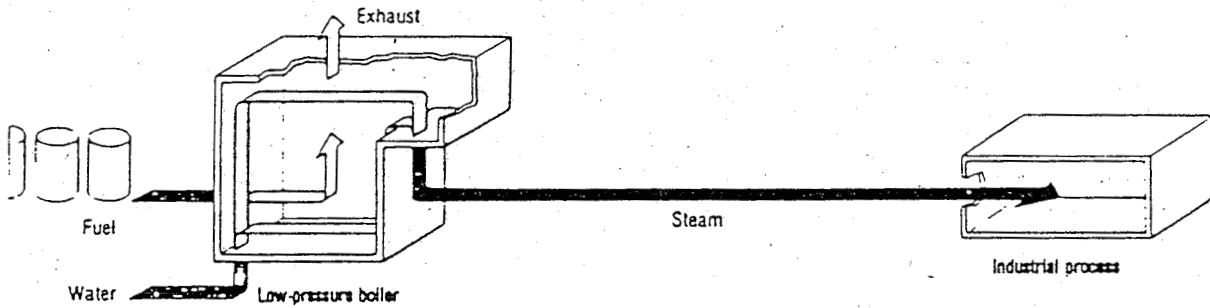
Figure 3.4-168

CONVENTIONAL ELECTRICAL AND PROCESS STEAM SYSTEMS  
COMPARED TO A COGENERATION SYSTEM

A Conventional electrical-generating system requires the equivalent of 1 barrel of oil to produce 600 kWh electricity.



B Conventional process-steam system requires the equivalent of 2 1/4 barrels of oil to produce 8,500 lbs of process steam.



C Cogeneration system requires the equivalent of 2 1/4 barrels of oil to generate the same amount of energy as systems A and B.

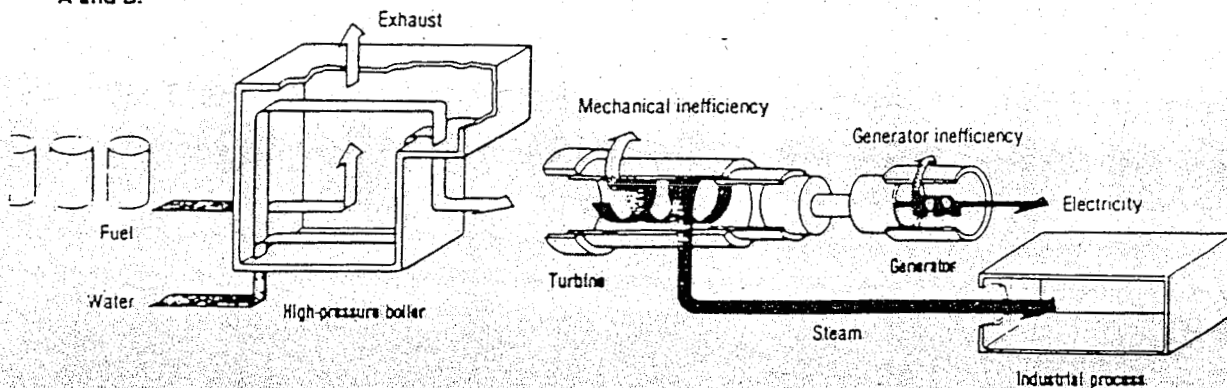
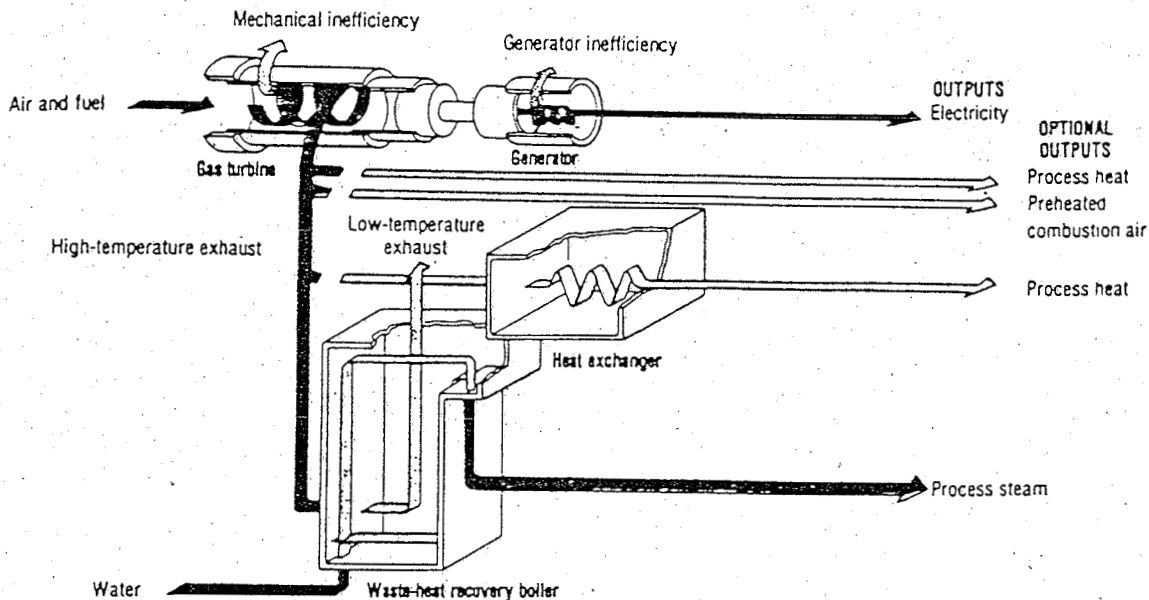


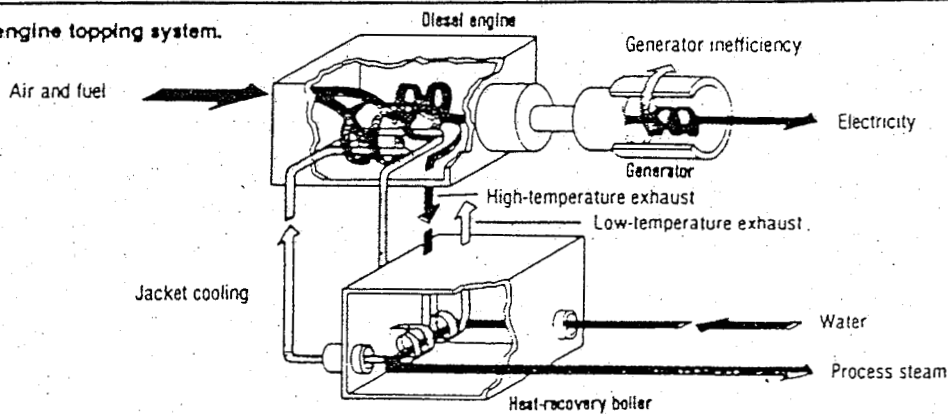
Figure 3.4-269

DIAGRAM ILLUSTRATIONS OF TOPPING  
CYCLE COGENERATION SYSTEMS

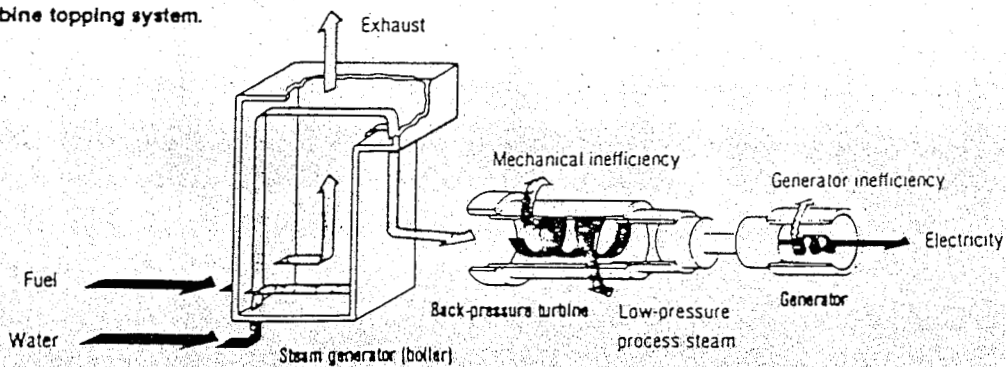
Gas-turbine topping system.



Diesel-engine topping system.



Steam-turbine topping system.



the gas turbine can be fitted with a back pressure steam turbine to make additional electricity and to provide relatively low pressure steam. The gas turbine system can produce an effective heat rate of 5,000 to 6,000 Btu/kwh and produce four to six times the average electricity output of a back pressure steam turbine. The efficiency of gas turbine, or gas turbine with a waste steam boiler compare favorably to central power plants as electrical generators. This cogeneration system utilizes 25 to 35 percent of its fuel, which is well within the range of single mode power plants. The efficiency is even more impressive when the waste heat recovery benefit is included.<sup>70</sup>

There are a number of variations possible, such as liquid metal turbines. These turbines substitute liquid metal in place of water to produce the steam to propel a turbine. Figure 3.4-3 shows a potassium-turbine topping cycle coupled with a gas and steam turbine fueled from coal. Conventional primary fuels such as coal, are burned to boil a liquid metal like potassium and convert it to vapor through a turbine. This hot metal vapor, after leaving the turbine, boils water and superheats steam to drive a conventional turbine. It is estimated that this liquid metal cogeneration system could reach efficiencies near 47 percent.<sup>71</sup>

New cogeneration approaches, using fluidized-bed and combined-cycle technology, will be commercially available in the 1980s. With fluidized-bed technology, crushed coal or other fuels are fed into a hot bed of dolomite or limestone that is kept suspended or "fluidized" by a stream of hot air from below. Water piped through coils immersed in the bed is converted to steam for subsequent electricity production. Fluidized-bed technology holds promise for being a clean-burning process for converting coal, as well as other low-grade fuels. The clean-burning nature of fluidized-bed technology will facilitate its acceptance.

Combined-cycle configurations join in one thermodynamic system a gas turbine which generated electricity, a steam generator which produces steam from the waste heat remaining in the gas turbine exhaust, and steam turbine which uses this steam to generate additional electric power. Figure 3.4-4 illustrates a combined-cycle topping system utilizing gas and steam turbines. This cogeneration system is limited by its need for high quality fuel suitable for gas turbine consumption, either natural gas or a light distillate. However, gas turbines can be easily retrofitted to existing generating facilities. Before the end of the century closed cycle (external combustion) gas turbines, stirling engines, and other technologies are likely to approach commercial status.<sup>73</sup>

At the other end of the cogeneration technology spectrum is the "bottoming cycle" which uses the heat from the lower temperature "bottom" of an industrial process or engine to produce electricity.

Table 3.4-172

DISTINGUISHING FEATURES OF TOPPING CYCLE  
COGENERATION SYSTEMS

<u>Distinguishing features</u>	<u>System</u>		
	<u>Gas turbine</u>	<u>Diesel engine</u>	<u>Steam turbine</u>
1. Type of fuel used	#2 light distillate oil or natural gas	Oil or gas	All types of fuel including coal
Advantage			Supports NEA conversion to coal objective
Disadvantage	Conflicts with NEA conversion to coal objective	Conflicts with NEA conversion to coal objective	
2. Capital investment required <sup>1/</sup>	\$500 per kw	\$550 per kw	\$1,250 per kw for coal 875 per kw for oil
Advantage	Low cost	Low cost	
Disadvantage			High cost
3. Efficiency in converting fuel to electricity <sup>2/</sup>	5,500 Btu's per kw	7,000 Btu's per kw	4,500 Btu's per kw
Advantage <sup>3/</sup>			
Disadvantage <sup>2/</sup>			
4. Electricity produced per unit of steam generated <sup>2/</sup>	200 kw per million Btu's of steam	400 kw per million Btu's of steam	50 kw per million Btu's of steam
Advantage <sup>4/</sup>			
Disadvantage <sup>4/</sup>			
5. Environmental effects	Gas produces little pollution	High nitrogen oxide and carbon monoxide emissions	High sulfur dioxide and particulate pollution with some coals
Advantage	No pollution control equipment needed		
Disadvantage		Exhaust may not meet purity requirements of some process heat applications	Expensive pollution control devices needed

<sup>1/</sup> Total installed costs assuming 5 MW capacity.

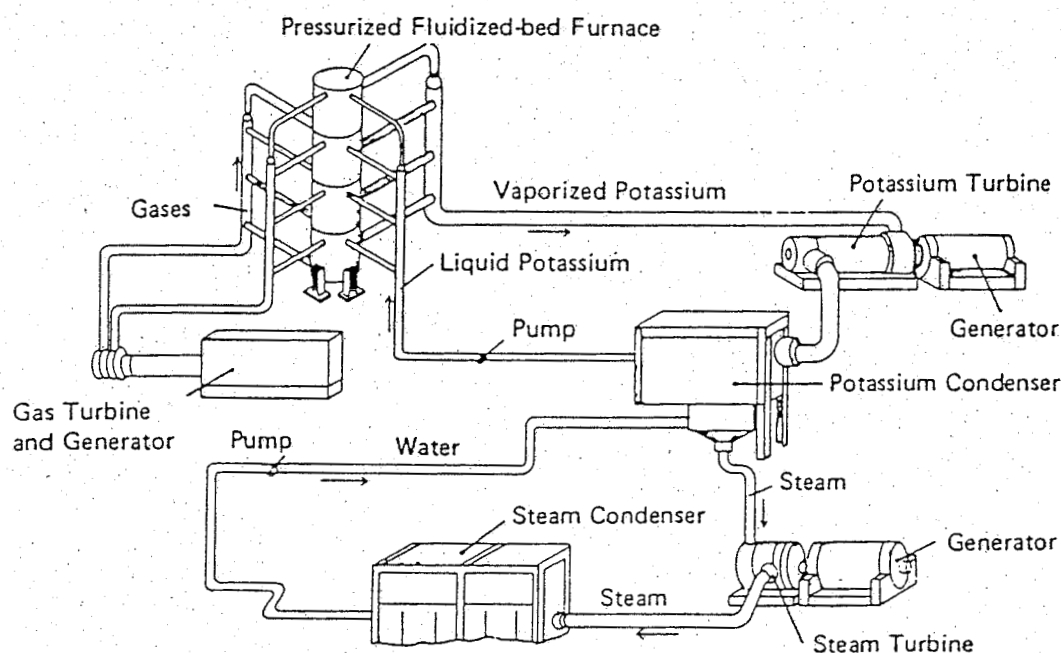
<sup>2/</sup> Federal Energy Administration and Thermal Electron Corporation, A Study of Inplant Electric Power Generation in the Chemical, Petroleum Refining and Paper and Pulp Industries. Final Report, 1976. p.2-1.

<sup>3/</sup> While steam and gas turbines are more efficient than diesel engines, their fuel efficiency cannot be universally considered an advantage. For example, in situations with large electricity to steam demands, the diesel, although less efficient, would be the most advantageous to the cogenerator.

<sup>4/</sup> Whether the amount of electricity produced is an advantage or disadvantage depends on the cogenerator's needs.

Figure 3.4-374

ALTERNATIVE TOPPING CYCLES: POTASSIUM TURBINES



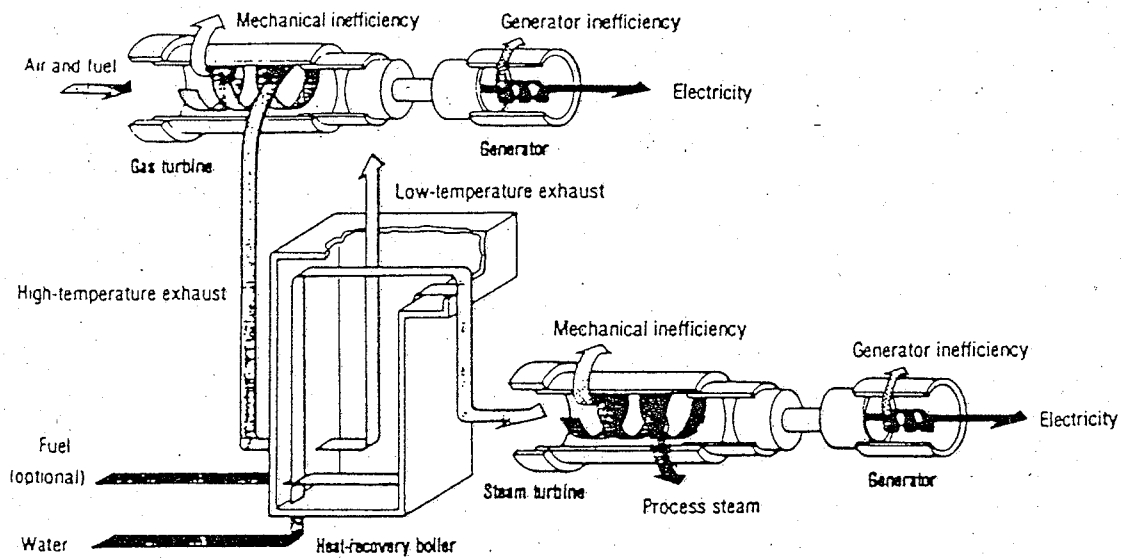
Industrial machinery and processes create large amounts of excess heat. This steam is usually dispensed indirectly to the environment or processed by expensive cooling equipment.<sup>76</sup> The heat can be extracted from industrial processes, such as cement kilns, blast furnaces, and glass manufacturing, to create steam that can be harnessed for additional use. There are a number of industries which require process heat in large amounts including food processing, textiles, pulp and paper, chemicals, and automobile manufacturing. Though the waste steam is not an exact fit in quality or quantity to all industrial uses, the potential for its utilization is great.<sup>77</sup>

The Fiat Auto Corporation of Italy has developed an energy system using an automobile engine linked to a heat exchange unit to utilize waste heat from the exhaust and generator. The prime mover of the system, called TOTEM (Total Energy Module) is a four-cylinder in-line engine that operates on a four-stroke Otto cycle engine linked to an electric generator to produce power. The internal combustion engine has a displacement of 55 cubic inches and can be set up to accommodate various fuels, including natural gas, manufactured gas, biogas, liquified petroleum gas, methanol, and other alcohols.<sup>78</sup>

A synchronous electric motor starts the power generator and serves as a regulator to maintain the module at a constant speed. The combination of technologies provides an energy system that Fiat rates at 90 percent efficiency based on the net value of a gaseous fuel.<sup>79</sup>

Figure 3.4-475

COMBINED-CYCLE TOPPING SYSTEM



The waste heat captured by the heat exchange unit of the TOTEM can be channeled into a variety of specific uses depending upon what is needed. The fifteen kilowatts of electricity and the waste heat energy generated by a TOTEM system can be applied to domestic, industrial, and agricultural sectors for substantial energy savings.

In the domestic sector, TOTEM's size and power generation capacity fit into not only residential units but also any private or community buildings requiring power and heat energy. TOTEM's power generation capacity is typically four or five times the average required for an isolated residential dwelling, thus lending itself to integration into multiple residential dwellings or use as a neighborhood resource. The system's modular nature allows expansion in small increments to keep pace with growing energy demand.<sup>80</sup>

The TOTEM system can be used in the industrial sector to provide power and heat. Heat in the form of hot water or other hot fluids can be provided for production processes. The modular capacity of the system allows it to be expanded quickly, (estimated installation time per unit is eighteen person-hours) to satisfy a multiplicity of industrial uses, such as space heating and water pumping.<sup>81</sup>

The TOTEM system fits into the agricultural sector with the development of technologies for the collection and synthesis of animal excrement and other organic



wastes into biogas. Various methods for the fermentation and distillation of vegetable matter into alcohol provide another diverse fuel source for the TOTEM system. On the farm this energy system can be used for drying, irrigation, powering farm machinery, and a host of other applications.<sup>82</sup>

The TOTEM system's benefit go beyond energy efficiency and flexibility. The Fiat Corporation estimates that a TOTEM will provide energy at a retail price of \$500 to \$600 per kilowatt.<sup>83</sup> This is more than competitive with the price of providing energy with a fossil fuel plant costing nearly \$1,000 per kilowatt of installed capacity.<sup>84</sup>

The Thermo Electron Corporation of Massachusetts has developed a total energy system concept similar to Fiat's TOTEM. Thermo Electron's system would use mass-produced Chevrolet automotive engines of the 454, 350, and 305 cubic-inch V-8 class. These engines are derated to operate at 75 percent throttle and 1,800 rpms. They provide continuous generator ratings of 60 kw, 47 kw, and 40 kw respectively.

The Thermo Electron module can provide a minimum of 2,000 hours of service at an operation speed nearly 40 percent lower than Fiat's TOTEM, and will achieve an overall efficiency of 86 percent and a theoretical 36 percent in the conversion of heat energy to work.

The major advantage of such a proposed system over TOTEM is that it utilizes a larger engine, which operates at a lower speed thus allowing for less service problems. The system prime mover contributes only about \$15 per kilowatt. This low cost makes it possible to reduce field maintenance expenses to a minimum.<sup>85</sup>

Cogeneration systems offer great potential in terms of efficiency and conservation. The United States Department of Energy determined in 1978 that cogeneration could provide as much as 6.15 quadrillion Btu per year of energy by the year 2000. This significant energy savings takes into account beneficial tax treatment and additional government action beyond the National Energy Act.<sup>86</sup> Dow Chemical Company forecasts that with complete relaxation of governmental and institutional constraints, industrial cogeneration could generate as much as 71,105 megawatts of power by 1985. This amount is 1.45 quadrillion Btu annually, or roughly the equivalent of 680,000 barrels per day of oil. These figures include only the byproduct power feature of cogeneration and not the incremental condensing power for electrical generation.<sup>87</sup> Table 3.4-2 gives the total potential energy savings from cogeneration with an estimate of market penetration.

The energy savings potential of central powerplant cogeneration has not yet been fully exploited, although a number of such plants are in operation today. Gulf States Utilities Company, located in a petrochemical complex near Baton Rouge, Louisiana, has been in operation since 1929. This plant produces electric power and steam for Exxon and Ethyl Corporations. This facility produces about 160 megawatts of electric power and approximately three million pounds per hour of industrial process steam.

Table 3.4-2<sup>88</sup>

TOTAL POTENTIAL ENERGY SAVING FROM COGENERATION  
AND ESTIMATED MARKET PENETRATION (QUADS)

Scenario Year without additional governmental action	1982		1985		1990		2000	
	Energy Saving	Estimated Market Penetration	Energy Saving	Estimated Market Penetration	Energy Saving	Estimated Market Penetration	Energy Saving	Estimated Market Penetration
	.11	.22	.31	.78	.60	1.53	1.03	1.58
With National Energy Act	.05	.12	.15	.38	.31	.79	.54	1.33
With additional government action beyond national energy act	.035	.11	.14	.67	.42	1.33	.71	2.24
TOTAL	.195	.44	.60	1.83	1.33	3.65	2.28	6.15

Large petrochemical complexes in Texas are also utilizing sophisticated cogeneration systems. American Oil Company, Monsanto Chemical and Union Carbide have tested cogeneration systems linked to utilities. Their particular cogeneration design uses coal-fired boilers and back-pressure steam turbines. The boilers generate three million pounds per hour steam at 10.3 MPa and 510°C, and the turbines deliver steam at varying pressures and temperatures for process, feedwater, daeration, and heating appliances. This system has total electrical generation capacity of 220 megawatts.

A General Foods Corporation plant in Massachusetts uses a cogeneration bottoming cycle. Oil fired boilers, producing 160,000 pounds per hour of steam at 4.14 MPa and 400°C feed a steam turbine generator that produces electric power. The low-pressure exhaust steam is then used in the manufacturing process for gelatin and chemical products.<sup>89</sup>

The efficient use of a fuel by cogeneration systems not only permits conservation of capital and dwindling fuel supplies, it also reduces the environmental impacts of energy use. Recovery of waste heat by either steam or organic fluid bottoming cycles reduces both thermal and air pollution produced by electricity generation. Heat normally discharged can be converted to useful work energy. The Thermo Electron company has estimated that a large fossil fuel steam

plant emits 55 percent more waste heat per unit of electricity than a five megawatt diesel facility equipped with a bottoming cycle. Further, it has been determined that a nuclear power plant emits 130 percent more excess heat per unit than the diesel cogenerator. Air pollution per unit of energy produced decreases with cogeneration because recycling waste steam to produce electricity reduces the need for additional use of the primary feedstock.<sup>90</sup>

Bottoming cycle plants have other environmental advantages because of their relatively small size. Conventional power plants cannot match the over 45 percent efficiency projected for diesel generators coupled with various bottoming cycles. The small size of these plants allows them to be located near the site where the power is needed, reducing the environmental impacts of transmission systems.<sup>91</sup>

The economics of cogeneration vary considerably. The U.S. Department of Energy has stated that "in general (the) cost of electricity production from cogeneration compares favorably with the projected cost of purchased electricity." DOE also considers various cogeneration technologies to be more efficient means of utilizing capital for power generation when compared to conventional plants. But industry notes that this fails to recognize that companies use a different set of criteria for investing capital to generate electricity than do utilities. The generation of power is merely a sideline; it does not represent an expansion of their normal product line.<sup>92</sup>

A Dow Chemical Study prepared several years ago compared four cogeneration combinations to conventional systems of power and steam generation. These in-depth case studies and their results can be summarized here as: (1) Industrial generation of power for internal use only; (2) Industry/utility joint venture dual purpose power facility; (3) Industrial generation for internal use and for the sale of excess power to the public, and (4) both industrial power generation facilities and dual-purpose central power stations. Cogeneration's major economic and financial impacts, according to the Dow Study, are (a) general savings in labor, capital, and fuel used; (b) reductions in the amount of capital that utilities must solicit from financial markets; and (c) decreased cost of electricity to consumers. The study noted that the need to generate capital for the electricity sector over the 1976 to 1985 period varied from \$2 billion per year in Case 1 to \$5 billion per year in Case 4. According to the study, the net savings for the period would be \$20 to \$50 billion, consumption of electricity could remain constant, and the cost of constructing energy facilities would decrease. The study concluded that the cogeneration alternative would free a sizable piece of the nation's energy resources for other pursuits.<sup>93</sup>

Industry maintains that cogeneration will not reach its full potential without a major impetus from the government. A task force for the National Association of Manufacturers has stated that:

Investment in cogeneration facilities would not be greatly increased by modest changes to depreciation schedules and/or investment tax credit. Almost certainly, massive doses of either or both would be required to prompt significant

replacement of existing non-cogeneration installations with technology that can deliver both electricity and useable steam. These firms consider a 50 percent investment tax credit coupled with first-year depreciation as the minimum incentive needed to produce a rate of return higher than 20 percent, a benchmark that companies typically use for discretionary investments.<sup>94</sup>

The cost of standby power is an additional constraint retarding the implementation of cogeneration. Standby power is the rate that utilities charge cogenerators that must occasionally purchase power to supplement their own generation capacity. High standby rates reduce the projects' competitiveness as a capital investment. Utilities commonly regard industrial cogenerators as potential competitors or energy liabilities that they must have the capacity to service.<sup>95</sup>

This is changing with utilities' increasing difficulties in sitting new electrical generation plants and raising large amounts of capital within inflated financial markets. Utilities have begun to view cogeneration plants as a source of energy for their system or as a means to reduce their need for increased generation capacity. Utilities are currently negotiating reduced standby rates or crediting cogenerators for their contributions to the conventional system. Utilities are also attempting to encourage cogeneration with various rate structures such as reduced standby rates for off-peak demand.<sup>96</sup>

The rates that utilities have been willing to pay for the electricity supplemented to their grids by industrial cogenerators have been an additional hindrance to cogeneration. The reason often cited by utilities for not paying reasonable rates is that cogenerators are not predictable and they cannot be depended upon for small additions to the conventional energy system. Some utility regulatory commissions are now mandating that utilities establish equitable rates for the purchase of excess electricity generated by their customers. For example, Southern California Edison developed a formula that pays the cogenerator a time-of-use price as a function of the average system energy cost. This price is adjusted semi-annually to reflect the prevalent energy cost for the cogenerator. Similarly, Pacific Gas and Electric Company has designed a rate structure for the purchase of cogenerated electricity that reflects on-and off-peak period and partial-peak period purchases of energy. The rates of these California utilities reflect the Public Utility Regulatory Policies Act mandates. As additional contracts are equitably negotiated for the purchase of cogenerated power, industrial firms with high-grade excess steam will take advantage of this incentive and reduce their demand from conventional power plants.<sup>97</sup>

A path to full-scale implementation of cogeneration is being cleared by two sections of the Public Utility Regulatory Policies Act (PURPA), enacted in 1978 and by some alterations in the Natural Gas Policy Act. Section 201 of PURPA requires state Public Service Commissions to set purchase rates for surplus power at rates that reflect the fuel prices in different sections of the country. Utilities must also provide standby power to cogenerators as they would typical electricity customers.

This section also exempts cogenerators from state regulation of utility rates and financial organization, as well as from restrictions mandated under PURPA and the Federal Power Act. Further, PURPA enables cogenerators to take advantage of investment tax credits. These credits, however, cannot be applied to oil or gas-fired systems.

The Federal Economic Regulatory Commission (FERC) (within the Department of Energy) is proposing the elimination of fuel-use restrictions for bottoming cycle cogenerators that produce predominately thermal energy. Potential industrial cogenerators have been wary of cogeneration for fear that the federal government might prohibit the burning of oil and gas in new facilities. Jerry Davis, General Manager of the Energy Systems Division of Thermo Electron Corporation noted that, "The FERC rules move a lot of cogeneration projects from (being) marginal to economic."<sup>98</sup>

There are still a number of regulatory and institutional barriers to cogeneration which must be overcome. It is unclear whether steam and electric sales fall under federal, state or joint regulation. Potential cogenerators have indicated they do not want to get involved with Federal Power Commission regulatory requirements. These include authority to prohibit the issuance of securities for exchange, stability or depreciation schedules, and various regulations, reporting and permit processes which which already overwhelm many companies.<sup>99</sup>

Clarification is needed as to whether waste-heat utilization projects with several partners are covered by the Public Utility Holding Act of 1935. The Act was designed to control abuses believed implicit in holding company structures. Various methods of cogeneration ownership such as having the cogeneration unit of the company as a subsidiary selling the excess power, could fall under this law.<sup>100</sup> This Act and other anti-trust legal tangles are slowing the full-scale development of cogeneration as an alternative energy resource.

Cogeneration technologies offer a number of advantages over conventional power plant technologies, in addition to their reduced use of primary fuels. Since they can be mass-produced in modular components, they have distinctive economics of scale in costs of individual sub-systems. For a strategic energy perspective, their reliability, energy economy, and flexibility of potential locations increase their value as dispersed, efficient power resources. Micro-cogeneration systems, such as the commercially available TOTEM and the proposed Thermo-Electron system have the added advantage of pre-engineered design which can be mass-produced to suit a variety of end-use needs. Unlike conventional power systems, which are large and site-specific, these micro systems are small and can be readily moved from one site to another. Micro systems can be readily utilized for emergency purposes, and can operate on a variety of fuels, including bio-mass derived gas. The potential for community self-sufficiency through the establishment of cogeneration co-ops is great.



## Fuel Cells (3.5)

A fuel cell is an electrochemical device that chemically combines hydrogen and oxygen to produce electricity and water. When combined with a fuel processor and power processor to form a fuel cell power plant, fuel cells are a clean, efficient, and flexible means of producing electricity.

Fuel cells so far developed use hydrogen fuel made from fossil fuels, though it is possible to convert biomass into hydrogen fuel as well. Fuel cell power plants work by reacting hydrocarbon fuel (such as naphtha or natural gas) in the fuel processor to obtain a hydrogen-rich gas. In the fuel cell itself, the hydrogen reacts in the presence of an electrolyte to produce direct current power. The power processor then converts the direct current to alternating current.

Fuel cells are distinguished from regular batteries by the fact that their electrodes are invariable and catalytically active. Reaction on the electrode surfaces which are in contact with the electrolyte produces current. Generally, fuel and oxidant are not an integral part of the cell; the current load supplies them as needed, and reaction products are continually removed.<sup>101</sup>

Though the electrolyte may be acid or alkaline, solid or liquid, phosphoric acid fuel cells are considered first generation. Phosphoric acid fuel cells are designed to use naphtha or natural gas as their primary fuel. Other possible fuel sources include distillate fuel oil, clean coal fuels, methanol, and hydrogen. Another possibility is connection to a wind generator, in which the wind generation system electrolyzes water into hydrogen and oxygen, and stores the hydrogen for later conversion to electricity in the fuel cell.

Generally, the refining process for fossil fuels is so complex that it seems to limit fuel cell applications to those on a large scale. Anhydrous ammonia, methanol, and synthetic fuels such as gasified coal are more easily processed into a hydrogen-rich steam.<sup>102</sup> It is possible that fuel cells will be used in conjunction with coal gasifiers. This second-generation technology would use molten carbonate salt as the electrolyte.<sup>103</sup>

Several different processes are now available for converting hydrocarbon fuel to hydrogen-rich fuel, including steam reforming, partial oxidation, and thermal cracking. The process used most is steam reforming with a nickel catalyst.<sup>104</sup>

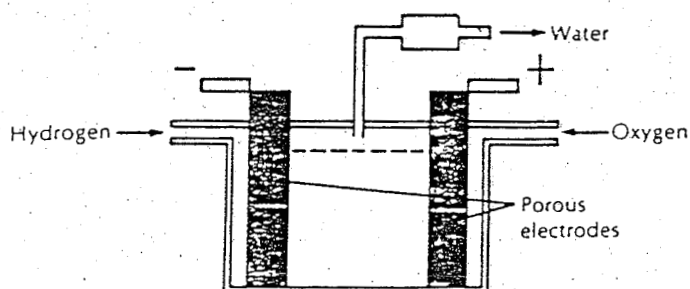
The actual fuel cell in a fuel cell power plant is made up of many single cells, each with an anode (-) fed the hydrogen-rich fuel, a cathode (+) fed air (oxygen), and an electrolyte solution to carry the ions between them. Each cell produces about one volt. A series of connected cells forms a "stack."<sup>105</sup> Each individual cell contains the necessary elements for sustained operation.

To illustrate the components and functions of fuel cells, a single type, the hydrogen-air cell with acid electrolyte will be examined. Figure 3.5-1 shows a schematic of such a cell.



Figure 3.5-106

### HYDROGEN-AIR FUEL CELL SCHEMATIC



A hydrogen-air cell consists of a pair of porous catalyzed electrodes with an acid electrolyte separating them. Reaction on the anode is the oxidation of hydrogen to hydrated protons with the release of electrons; on the cathode it is the reaction of oxygen with protons to form water vapor with the consumption of electrons. Electrons flow from the anode through the external load to the cathode; ionic current transport through the electrolyte closes the circuit. In an acid cell, protons carry the current.<sup>107</sup>

An advantage of this type of cell is that reactants need not be pure. Hydrogen may come from fuel mixtures and oxygen from air. Oxygen-depleted air removes product moisture from the cathode, facilitated by the cell's operation at sufficiently high temperature to vaporize the water that is formed.

The electrolyte is the center of the fuel cell's operation. In its catalyzed layer, it offers many places where gases and electrolyte can react. Its porosity makes possible fast reactant transport and removal of inert material and product moisture. The electrode also serves as the path for current flowing to the terminals and often contains the electrolyte. The electrolyte, besides providing ionic conduction, assures that reactants remain separate.<sup>108</sup>

According to Earl Cook, fuel cells should be theoretically able to achieve conversion efficiencies of 100 percent.<sup>109</sup> While laboratory tests have achieved efficiencies as high as 75 percent, a more common figure is about 60 percent.<sup>110</sup> An advantage of fuel cells is that their efficiency remains consistent over a wide range of loads.

Practical fuel cells are unable to reach the maximum possible conversion efficiency because of the intrinsic inefficiency of the conversion process rather than from operation losses such as need for auxiliary power. Two basic losses encountered by fuel cells are the ohmic loss in the electrolyte, and the electrode polarization which is the difference between the actual and thermodynamic electrode potential. Electrical resistance in the electrodes and conductors leading to the cell terminals can also be a problem, since fuel cells are a low-voltage device and conduct high currents.<sup>111</sup>

Fuel cells are built in relatively small modules (40 kw to 26 kw) that may be connected to form a larger unit, or operate as equally effectively as discrete units. The U.S. Department of Energy considers 4.8 MW to be the "optimum rating for a power plant building block," and believes that one to two 4.8 MW units could provide the "full requirements of dispersed load centers."<sup>112</sup>

Among the many possible combinations of electrolyte, fuel, electrode configuration, and operating temperatures, several have emerged as the best candidates for power plant building blocks. These include cells with aqueous electrolyte, with fused salt electrolyte, and cells which operate at very high temperatures, in which oxygen ion mobility in the solid state provide ionic conduction. The most advanced of these are phosphoric acid fuel cells which operate below 175°C using aqueous or quasi-aqueous electrolyte.

Aqueous electrolyte cells are favored now because of the high specific conductivity of the electrolyte, higher cell performance at ambient temperatures, and material stability. They can be differentiated by the mode of electrolyte containment.

Some manufacturers use free-flowing electrolyte contained by the electrodes or porous membranes adjacent to the electrode. Others render the electrode hydrophobic, enabling the cell to operate at atmospheric pressure. Matrix-type cells which are compact, and inexpensive to manufacture retain the electrolyte in a microporous mix such as asbestos by auxiliary forces. These cells use hydrophobic electrodes, which can be thinner and more porous than free electrolyte cells because they don't need to contain the electrolyte.

A vital aspect of fuel cell technology is continuous supply of reactants and removal of reaction products and heat generated by conversion losses. A cell's design, particularly for aqueous electrolyte cells, depends a great deal on methods of maintaining the mass and energy balance. Some manufacturers achieve this balance by recirculating the electrolyte. In matrix-type cells the electrolyte is fixed, and there is less of it than in free-electrolyte cells. Balance is maintained by circulating the hydrogen since reactants need not be recirculated in this type of cell.<sup>113</sup>

Fuel cells have many advantages and few drawbacks as an energy generating technology. Being a low-temperature conversion device, their emissions of sulfur oxides, nitrogen oxides, and particulates are far below the strictest governmental air quality standards. They require no water for cooling or processing; rather, they produce it. They are highly dispersible, requiring less in the way of transmission lines, because their modularity and low environmental impacts allow them to be sited near load centers. Their already high efficiency can be augmented by utilizing the waste heat, for an overall system efficiency as high as 80 or 90 percent. Fuel cell power plants take only two years to construct, and they can use a wide range of fuels. They have no moving parts to replace or maintain. As Cook points out, "Unlike a battery, in which the electrolyte changes composition and the electrodes are consumed, the fuel cell does not need to be recharged or replaced; it can operate as long as fresh fuel is supplied."<sup>114</sup>

The one major limitation of fuel cells is their reliance on noble metals (usually platinum) for the electrolyte catalyst.<sup>115</sup> Fuel cells compete with the environmentally beneficial catalytic converter, used to reduce exhaust emissions in many new cars, for this expensive imported metal.

Like another relatively new energy technology, photovoltaics, fuel cells are a product of the space program. The National Aeronautics and Space Administration adopted the fuel cell principle in the early 1960s as a highly efficient and reliable electrical generator of high energy density, and used it in spacecraft. Soon there were about 50 U.S. companies researching and developing fuel cells. After several years of effort, it was apparent that the first important breakthroughs could not sustain commercialization and that the success of the fuel cell would depend on long-term research and development efforts. By 1975, all but a few companies had abandoned fuel cell research, and only United Technologies Corporation was doing significant work.

Now the Department of Energy has become interested in the fuel cell, particularly the 4.8 MW size. In cooperation with the Electric Power Research Institute (EPRI) and United Technologies Corporation, the DOE is building a demonstration plant for Consolidated Edison of New York, to be completed this year. Unfortunately, its performance will not approach that of a commercial power plant; the demonstration is designed to operate for "no more than 10,000 hours;" to be fully commercial such a plant must last 40,000 hours.<sup>116</sup> The Electric Power Research Institute's \$9.6 million (FY 1980) Fuel Cell and Chemical Energy Conversion Program is now concentrating on commercializing fuel cell power plants "for dispersed applications in the near-term." EPRI is also constructing a twenty kw "breadboard" molten carbonate fuel cell power plant, to be completed this year. The Institute also plans to test integration of a molten carbonate fuel cell with a coal gasifier.<sup>117</sup>

EPRI expects first-generation (phosphoric acid) fuel cells to be commercially feasible by the mid-1990s. Second-generation technology (molten carbonate) is expected to be commercially feasible sometime after 1990.<sup>118</sup>

Deployment of fuel cells hinges at present on fuel availability and cost. As noted earlier, fuel cells are currently designed to use either natural gas or naphtha, both fossil fuels. Coal-derived synthetic fuels, not yet on the market, and methanol from biomass, are other fuel possibilities.<sup>119</sup> According to Rich Lang of the California Energy Commission, total costs are roughly comparable to gas turbine generation technology, though it should be noted that fuel cells will greatly reduce transmission costs.<sup>120</sup> Transmission considerations make home use of fuel cells more efficient than fuel cell power plants, a siting choice few generating technologies can offer.

### Small Hydroelectric Power (3.6)

Small hydroelectric power systems are water-electric power systems up to 30,000 kilowatts (30 MW) in size. The hydraulic "head" is comparable in most cases to that found in larger hydro installations, but a smaller water flow restricts electrical capacity. Conventional, but smaller turbines, generators, governors, and control equipment are used in small hydroelectric plants.

Small hydro power facilities are used in many parts of the world with extensive installations in Europe. The People's Republic of China is the world's leader in small and micro hydro power with over 90,000 installations providing more than 5,400 MW. The Chinese small hydro plants are quite decentralized in nature, and are either not grid-connected or feed power to local grids for small industries associated with rural communities.\*

Interest in the development of small hydro power has been rekindled in the U.S. in recent years; small hydro was identified as a key source in the National Energy Plan, and major efforts by the Department of Energy (through the Federal Energy Regulatory Commission (FERC)) have placed small hydro development as a high government priority.

In 1975 the U.S. Army Corps of Engineers published a five volume study, A National Program of Inspection of Dams.<sup>122</sup> This study provided the base data on existing hydropower facilities. It contains geographic, physical and ownership data on approximately 50,000 dams in the U.S. Much more limited data has been available on undeveloped sites. Only about 5,000 sites had been identified or previously studied by the Corps and other local, state and federal water resource agencies. In addition, in the 1975 inventory, pumped storage sites and conduit hydro projects, as distinct from dams, were not surveyed.

The data from this inventory is currently being reviewed by the Corps and is the basis for an extensive study of existing and potential hydropower capacity. A Preliminary Inventory of Hydropower Resources,<sup>123</sup> was published in July, 1979. This study indicates that currently existing hydroelectric power facilities generate 63,702 MW. Of this total, 2,957 MW are produced at small-scale sites (05-15 MW); 1,517 MW are produced at intermediate sites (15-25 MW); and 59,230 MW are produced at facilities larger than 25 MW. Table 3.6-1 outlines the number of sites, capacity and energy produced for total U.S. small, intermediate and large-scale hydroelectric facilities.

\* China treats decentralized sources of energy, such as hydro and other small power plants, as a key ingredient in civil defense planning. Underground shelters and dispersed military installations are served throughout the country by dispersed electric grids fed by small power facilities.<sup>121</sup>

Table 3.6-1124

PRELIMINARY INVENTORY OF HYDROELECTRIC POWER RESOURCES  
NATIONAL TOTAL

Existing,<sup>1</sup> Potential Incremental<sup>2</sup> and Undeveloped<sup>3</sup> Capacity Ranges

	Small-Scale (0.5-15 MW)				Intermediate (15-25 MW)			
	Exist	Incre	Undev	Total	Exist	Incre	Undev	Total
NUMBER OF SITES	842	4,813	2,642	8,297	81	166	387	634
CAPACITY (MW)	2,957	5,455	8,010	16,422	1,517	3,320	7,722	12,599
ENERGY (GWH)	15,048	17,267	28,843	61,158	6,717	7,859	23,503	38,079

	Large-Scale (Greater Than 25 MW)				All Sizes			
	Exist	Incre	Undev	Total	Exist	Incre	Undev	Total
NUMBER OF SITES	238	445	1,503	2,276	1,251	5,424	4,532	11,207
CAPACITY (MW)	59,230	85,859	338,217	483,306	63,702	94,636	353,948	512,286
ENERGY (GWH)	258,239	198,087	883,519	1,339,845	280,004	223,214	935,867	1,439,085

<sup>1</sup> Existing hydroelectric power facilities currently generating power.

<sup>2</sup> Existing dams and/or other water resource projects with the potential for new and/or additional hydroelectric capacity.

<sup>3</sup> no dam or other engineering structure presently exists.

As this table shows, there are over 5,600 small-scale dams in the U.S. either generating power or with the potential for incremental development to add generating capacity. Annual energy generation at existing small-scale facilities is estimated to exceed 15,000 gigawatt-hours. These value for small-scale capacity and generation represent about five percent of the nation's current installed hydroelectric capacity and energy, according to the Corps. The incremental capacity which could be developed at existing sites could add another 5,400 MW to small hydro's total contribution. The total potential for the U.S., including all three categories of existing, incremental, and undeveloped sites, is given as over 16,000 MW, with a possible total generation of 61,158 gigawatt-hours.<sup>125</sup>

Ongoing studies are being conducted by the Army Corps of Engineers as part of the National Hydroelectric Power Study. These studies include the hydroelectric potential of projects of every size. The final national report will be developed by regions of the National Electric Reliability Council (NERC). The National Report should be completed and sent to Congress in October, 1981.



The distribution of existing small power production facilities is extremely variable and nearly all regions of the country have the potential for incremental energy development. Currently the greatest number and density of small scale hydropower installations are in the Northeast and Lake Central regions of the country. The undeveloped hydroelectric potential at small-scale sites is widely distributed, but appears to be greatest in the Pacific Northwest, Lake Central, and the Northeast regions.<sup>126</sup>

Corps estimates of future potential are only approximate and do not take into account classes of hydro projects such as those associated with canal drops, pipelines, pressure breaks, and other facilities which are part of municipal and district water supply systems. These sites are becoming increasingly attractive as the economics of energy production change dramatically, and many such projects are under study. The federal government has recognized the important of such projects and has written regulations granting exemption from the Federal Energy Regulatory Commission licensing procedures for manmade conduits generating hydroelectric power. For projects up to fifteen MW, exemptions have been given under most circumstances. In states such as California, with extensive water supply and irrigation systems, the potential for small-scale hydro power is considerable. For example, the California Department of Water Resources has recently selected 28 sites for preliminary feasibility studies. Of these 28, sixteen are sited at canals, tunnels, or pipelines; twelve projects have been sited at existing dams. The first estimate of this one round of studies indicates a capacity of 6,615 kw (6.6 MW) at an average of a little over 400 kw (.4 MW) for the sixteen conduits. Projects are also being investigated for hydroelectric production at pressure breaks in the Metropolitan Water District of Southern California and by the water departments of an increasing number of municipalities. The development potential of these small and micro hydro resources has not been surveyed. It can be expected, however, that such conduit rated projects will make an increasing contribution to capacity and energy production.



Hydroelectric technology, on any scale, is designed to exploit the kinetic energy of falling water. The equipment designed to translate the energy of falling water into a useable form is the turbine. A water turbine is the device that converts the energy in falling water into rotating mechanical energy. This energy, available in a rotating shaft, may either be used directly to operate equipment or connected to a generator to produce electricity.

Impulse units are generally the simplest of all common turbine designs and are widely used in micro-hydro applications. Impulse turbines use the velocity of the water to move the runner rather than pressure as is the case with reaction designs. In general the turbine is a disc with paddles or buckets or sometimes blades attached to the outside edge.

The water passes through a nozzle and strikes the buckets, blades or paddles, one at a time, causing the wheel to spin.<sup>127</sup> In a common type of impulse turbine, the Pelton Wheel, buckets are used for greatest efficiency. Each bucket is split in two so that the water stream is split in half and caused to change direction, heading in the opposite direction to the original water stream. Because the power developed by a Pelton Wheel is largely dependent on the velocity of the water, it is well suited for high head and low flow installations. Operating efficiencies in the 80 percent range are common, and very small units using the Pelton Wheel are produced by several firms in North America.

A variation on the Pelton Wheel uses blades with an outer rim enclosing the fan shape. The water stream is applied to one side, runs across the blades and exits on the other side. Like the Pelton, it is possible to use more than one water jet on a single wheel in situations where relatively lower head and high flow are present. As with the Pelton, the wheel itself is made in relatively few sizes and different nozzle sizes are used to match the equipment to the site conditions. This type of unit, called the Turbo Impulse Wheel, is made exclusively by Gilkes of England.

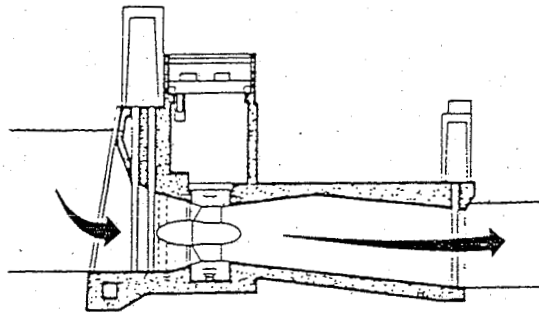
The Crossflow turbine, another type of impulse turbine, is constructed with a drum-shaped runner, the drum having blades fixed radially along the outer edge. Water flows in one side and after having exerted force on one part of the drum, flows across and exits from the other side, having applied force to the blades again as the drum turns. Because of its design, the Crossflow is said to be largely self-cleaning, and it is well suited to low head applications. The major manufacturer of these turbines, Ossberger of West Germany, has installed them successfully in sites with only one meter (39 inches) of head. The Crossflow turbine is used widely around the world, although none have yet been installed in the United States.

Reaction turbines, while functionally the same as impulse design, work, on a different principle. The runner is placed directly in the water stream and power is developed by water flowing over the blades rather than striking each individually. Reaction turbines use pressure rather than velocity.<sup>128</sup> They tend to be very efficient in specific designed-for sites, but their efficiency falls sharply with variation. Reaction units are usually used in very large installation. The Francis turbine in particular is used in the largest of the country's hydroelectric projects.

Other reaction turbines are generally variations on the propeller design. Some of these turbines operate in a tube with fixed propeller blades. If the unit is integrated with a generator, and the whole unit is in a case submerged in the stream flow, the mechanism is called a bulb unit. Figure 3.6-1 illustrates a bulb turbine. If the conduit bends just before or after the turbine, then the turbine can be connected to a generator sitting outside the flow itself. A variation of propeller turbines, the Kaplan, allows for greater flexibility in use, with variation in the flow and pressure of the water. Figure 3.6-2 describes a Rim-generator turbine and Figure 3.6-3 describes a Tubular-type turbine.

Figure 3.6-1<sup>129</sup>

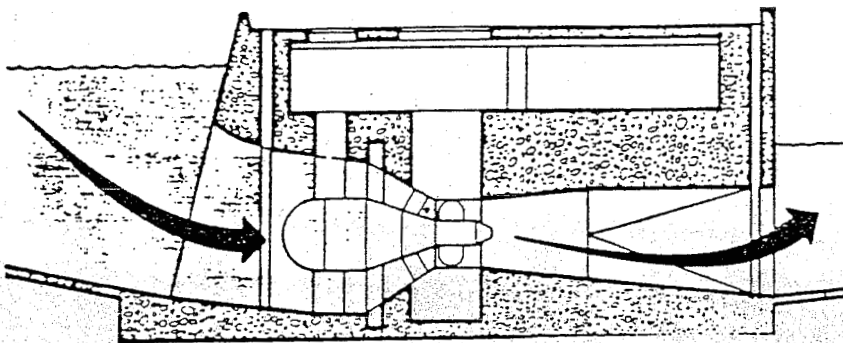
RIM - GENERATOR TURBINE



The energy efficiencies of turbines run generally between 75 and 95 percent. Francis turbines have very high efficiencies of up to 95 percent when operating at designed pressures, but they are generally more expensive than other types and quickly become inefficient as pressure and flows vary from design specifications. Impulse turbines have flatter efficiency curves and generally are less expensive.

Figure 3.6-2<sup>130</sup>

BULB - TYPE TURBINE

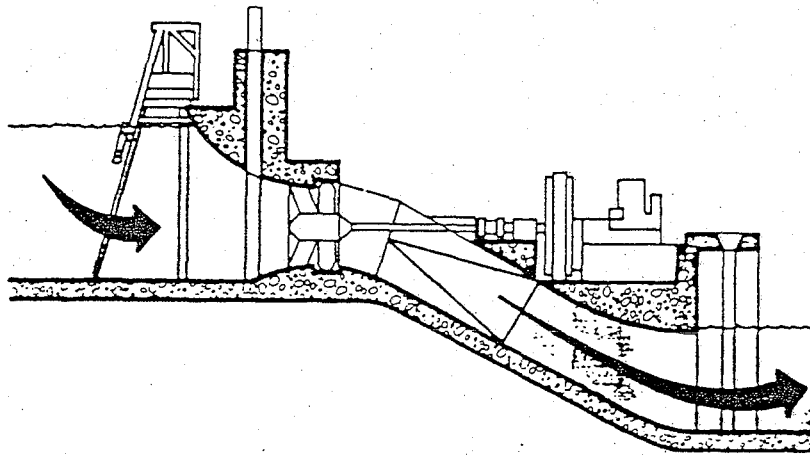


The bulb-type turbine generator is in a bulb-shaped watertight steel housing located in the center of an enlarged water passage.

Transmission of power from the turbine to the generator entails power losses. Belt drives are 95 to 97 percent efficient for each belt. Gear boxes are generally 95 percent efficient. Generators themselves are usually about 80 percent efficient. Thus, overall efficiencies for electrical generation systems can vary from 50 to 75 percent, with the higher overall ratings in the high head, high speed impulse turbines.

Figure 3.6-3<sup>131</sup>

TUBULAR-TYPE TURBINE



The tubular-type turbine uses a conventional horizontal propeller turbine and an attached generator located outside the water passage.

There are basically two types of generators, the synchronous and induction. The induction generator obtains its excitation from the power grid. The general method of getting an induction power plant on line is to start the generator as a motor with the turbine runner spinning "dry" and then opening the wicket gates of the turbine to load the unit. The generator then begins to operate as a generator. By comparison, a synchronous generator is synchronized to the grid system voltage and frequency before the breaker device (which connects the generator to the system) is closed. When connected, the generator continues to operate at synchronous speed. The voltage is determined by the strength of the field; therefore, a voltage regulator is required for a synchronous generator. Because synchronous generator frequency is determined by speed, a governor is required for exact control and a synchronizer is needed to compare the magnitude and displacement of alternative current waves with paralleling generators.

Current costs for induction generators are somewhat less than for synchronous generators of the same output rates. On the other hand there are penalties in the operation of an induction machine amounting to one to two percent loss of efficiency. Generally, induction generators are only suitable in small sizes, generating electrical power into an operating system. There are a number of advantages to a generation system that can start up if there is no possibility of connecting to the grid. The advantages of synchronous generators in times of emergency may become decisive. The DOE publication, Micro-Hydro Power, suggests, "If you intend to be completely independent from the power grid, a synchronous generator is used."<sup>132</sup>

A direct current (DC) generator is another way of generating electricity which will allow for independence from the power grid. This system has several advantages, especially in very small systems (e.g., less than five kilowatts). The excess power generated by a DC system can be stored in batteries, thereby extending the system's peak capacity. DC generators are not speed-sensitive and no governor is needed. Battery storage systems with hydro generation generally compare more favorably than wind power systems because the hydro generator generally continues to replenish the battery set. This means that a deep discharge condition common with wind systems is very rare. Deep discharge is a common cause of battery failure. However, the storage function limits the size of a DC system as batteries become unwieldy and very costly in systems over six kilowatts.

In times of emergency, particularly if the emergency is short-lived, the availability of DC system equipment could be critical. DC power generation would greatly extend the useability of the equipment.

The ability of a community to use the surviving electrical generating potential of small hydro projects depends upon the type of generating equipment and its independence from the grid, according to the technical conditions described in this section.

## Solar Heating and Cooling (3.7)

### Introduction and Overview (3.7-1)

Solar radiation is an abundant yet diffuse source of energy. In its diffuse form it can be used for space and water heating; alternatively it can be concentrated to provide industrial process heat or to generate electricity. It has been estimated that solar energy technologies may contribute up to twenty Quads<sup>133</sup> or twenty percent to the national energy budget by the year 2000. (1 Quad =  $10^{15}$  Btu)

The following four major solar conversion technologies are considered here:

- Solar Heating and Cooling
- Solar Thermal Electricity
- Ocean Thermal Energy Conversion (OTEC)
- Solar Photovoltaics

The first technology, solar heating and cooling applied to space heating and water heating, includes very simple systems as well as some of the most advanced technology in the solar field. These low-temperature applications of solar energy are practical for both residential and industrial use. Solar energy can be used to heat structures simply by architectural design that enhances the solar gain of the structure. The efficiency of solar heating can be increased as conservation and other heat retention methods (e.g., insulation) are incorporated into the design.

Another way to absorb diffuse solar energy is to heat air or water in a flat plate collector. This collector is basically an absorbing surface in contact with channels that circulate the air and water to be heated. These components are usually placed in a glazed, insulated box to maximize heat gain.

To generate temperatures greater than 180°F (82.2°C), solar energy must generally be concentrated. This is achieved by focusing the solar radiation that falls on a large collector surface onto a smaller receiving area. Collectors with a reflective surface shaped into a trough can produce temperatures up to 500°F (260°C) in a receiver at the line of focus. Parabolic dish-shaped concentrators capable of focusing sunlight can raise temperatures in the receiver up to 1500°F (815.6°C). Equally high temperatures can be achieved with fields of mirrored, flat solar tracking collectors called heliostats that direct sunlight to a central receiving point. Steam produced from these high temperatures can be used to generate electricity with a conventional steam turbine. Organic fluids that boil at lower temperatures can be solar heated between 200°F and 500°F and used to power a turbine called an organic Rankine cycle.



Photovoltaic (PV) cells generate an electric current by using the sun's energy directly to initiate a flow of electrons within the materials that comprise the solar cell. They can be grouped in flat plate modules or placed at the focus of concentrators with parabolic troughs or Fresnel lenses.

The abundance of solar energy makes it an ideal energy source for decentralized energy systems. Storage methods can extend its use to non-sunny periods. It is a resource that can be "mined" everywhere. Every country has some access to this resource, although not every country has equal access to the technology required to use it.

Solar energy can be used at many levels, from individual remote applications to centralized power stations. The overall ability to mix and integrate these levels gives solar energy its flexibility.

The following discussion of solar heating and cooling, solar thermal electricity, ocean thermal energy conversion, and solar photovoltaics includes a description of the theoretical basis of the technology, its practical applications, an assessment of its current state of development, current or projected costs and energy potential, strategies that will speed commercialization and an analysis of its appropriateness for centralized or decentralized applications.

From the viewpoint of community self-sufficiency a major advantage of passive solar applications (and of the simpler kinds of active systems) is that they can be implemented in most cases with readily available materials and local manufacturing resources and personnel. In an emergency, such as a prolonged breakdown of the national electrical power grid, this local fabrication capability could contribute significantly to survival. Materials like wood, glass, sheet metal and black plastic tubing are easily obtained in most communities, or salvageable from other applications, along with such critical components of active systems as motors, pumps and valves. The skills to install and maintain these systems are present in local manpower pools (electricians, plumbers, carpenters, glaziers, etc.).

On the other hand, solar photovoltaics also offer certain advantages for community self sufficiency. PV power is instantly available once the modules are deployed. They require virtually no maintenance. The stockpiling of solar PV arrays as a source of emergency power for critical needs (along with the requisite storage batteries if 24-hour power is required) could be valuable insurance for many community agencies (e.g. fire, police, health care, local government).

#### Space Heating and Cooling Applications (3.7-2)

Solar radiation reaching the earth's surface is composed primarily of shortwave visible light and longwave infrared heat.<sup>134</sup> When shortwave solar radiation strikes a surface it is either reflected, transmitted, or absorbed. If the light is absorbed, it is transformed into heat. The heat is either stored in an object, conducted to adjacent cooler objects, or re-radiated to space.



Solar space heating is based on the fact that glass transmits light, but reflects heat. While the shortwave "light" component of solar radiation is transmitted through glass, the longer wave infrared "heat" component is absorbed by the glass or reflected to the exterior. When the transmitted light hits an interior object, the light is absorbed by the object and converted into heat. This heat is radiated from the object to the air in the structure and glass prevents the rapid loss of heat. On cloudy days or at night, interior heat is absorbed by the glass and conducted to the exterior. Heat loss can be minimized by using conservation techniques such as insulating shutters inside or outside the glass.

Heat retention within the structure can be increased by the use of "thermal mass" or materials with high sensible heat capacity such as rocks, water, tile, masonry, adobe, or materials which store latent heat such as eutectic salts. Thermal mass heats up and cools off more slowly than air. Its presence moderates the air temperature changes in the structure by absorbing excess heat during the day and gradually releasing it when the air temperature drops below that of the thermal mass.

There are three basic approaches to solar space heating and cooling and water heating design. They are referred to as passive, active, and hybrid.<sup>135</sup>

Passive approaches rely on both the natural upward flow of hot air or hot water to distribute heat from the point of collection to the point of use or storage and on the conduction of heat from exterior to interior through walls with subsequent re-radiation to interior objects.

Active systems use fans or pumps to move hot and cold air or water in directions other than those they would go if left undisturbed. Thus an active water heating system's storage tank can be below the collector because a pump forces the hot water down, overpowering its natural upward convective motion.

The hybrid approach, uses a mix of the above technologies. Usually the distinction between a hybrid system and an active system is that they hybrid systems use a passive collection technique with an active distribution system.

### Passive Solar Heating

In the passive approach to solar heating and cooling, the size and configuration of standard architectural elements are modified so they significantly contribute to the collection, distribution, and storage of solar energy in cool weather and the rejection and ventilation of heat in warm weather.<sup>136, 137</sup>

Thus south-facing glazing is emphasized to maximize winter solar gain. External shading devices and vegetation are employed during summer months to minimize solar gain. Floors and walls can be made massive to store excess collected heat for nighttime or cloudy-day use in the winter. During the summer, the mass effectively reduces the daytime air temperature because of its ability to retain far more heat per cubic foot (meter) than air. It can then be "flushed" of heat at night through ventilation and re-radiation to the surrounding area.

Good ventilation is especially important in passive structures since they usually rely on natural air flow for cooling. By the appropriate choice of the number, size, and location of windows, vents, doors, and chimneys, cool nighttime breezes can be pulled in as the interior hot air is exhausted by convection. While passive cooling works well in hot, dry climates because they become cool at night, it is not effective in hot, humid ones that stay hot all night. However, new techniques in passive cooling are being evolved rapidly to deal with this problem.

The orientation of the structure on its site is also extremely important. The ideal location is one that receives the greatest amount of sunlight between 9:00 AM and 3:00 PM during the winter months. If the structure is located at the northern edge of the sunny area on the site, outdoor shading will be minimized. Generally an east-west long axis takes advantage of solar gain in the winter and minimizes heat gain from the hot western sun in summer afternoons. However, the optimal building geometry does vary significantly in the country's four major climatic regions.

A structure can be warmed or cooled by its relationship to local topography, sun angles, trees and other plants, ground water, precipitation patterns, and other aspects of local climate and geography.

The simplest passive solar design is direct gain. The sun directly enters the living space through large double-paned south-facing windows or rooftop clerestories. The roof angle and overhang are designed to maximize entry of low-angled winter sun and minimize entry of high-angled summer sun. The entering sunlight directly hits the storage materials, such as walls and floors, and transfers its energy to them.

Overall, direct gain design lends itself to successful operation in cool areas with cold but relatively clear winters and hot-dry summers. Cloudy days usually require back-up heat. Increased mass can offer longer storage, but increased mass in very cloudy and foggy climates is not advised because the mass takes longer to heat and adequate storage may rarely be achieved, resulting in underheating.

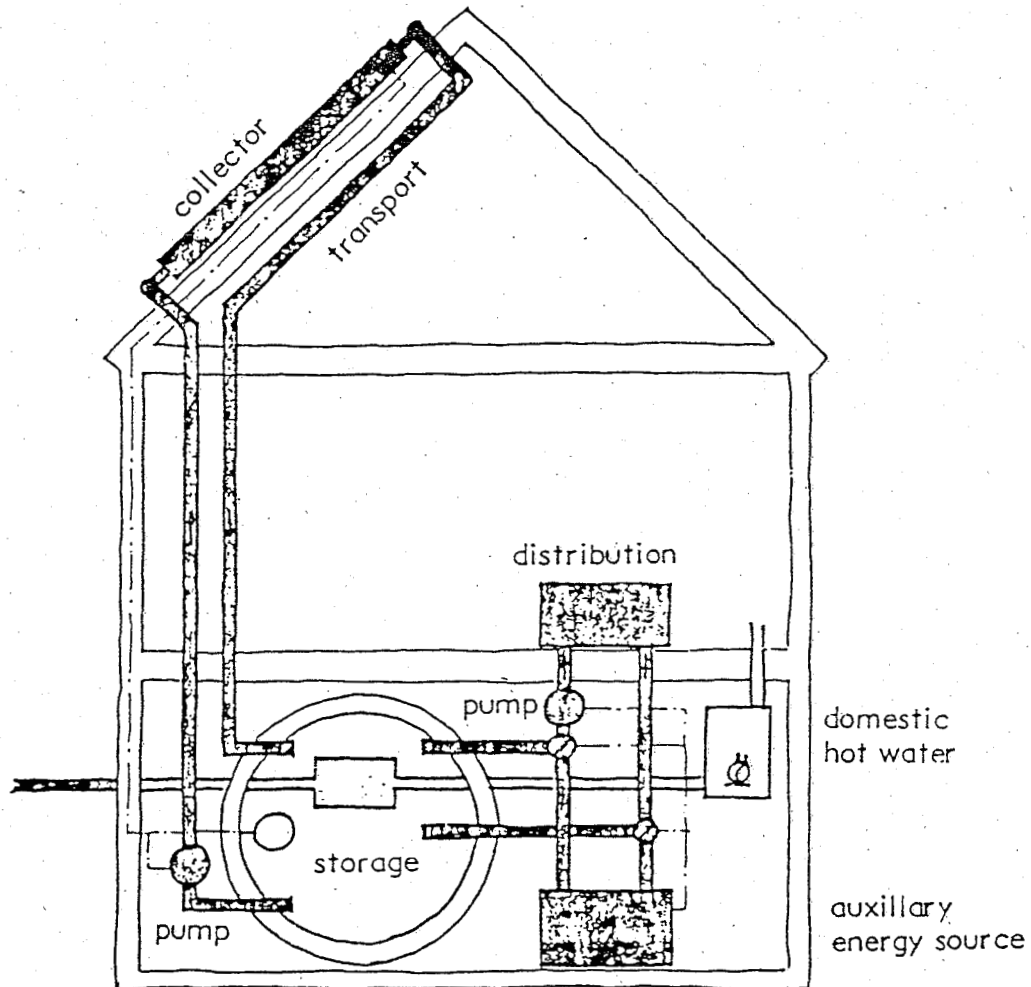
With indirect gain systems, the thermal mass is situated between the sun and the living area. The thermal mass is warmed and transfers its heat to the living areas by either direct radiation or through convection currents of warm air. There are four basic indirect gain strategies: 1) thermal storage walls of masonry or water located behind south-facing windows; 2) ponds of water located on a heat-conductive roof; and 3) a south-facing attached greenhouse that shares a common wall with the structure to be heated; and an air collector located beneath the structure.

### Active Solar Heating

Active solar space heating systems use flat plate collectors to heat air or liquids which are circulated to a heat exchanger directly to the point of use or indirectly via rockbed, water or eutectic salt storage. <sup>138, 139, 140</sup> Figure 3.7-1 shows a typical liquid flat plate solar system.

Figure 3.7-141

LIQUID FLAT PLATE SPACE HEATING SYSTEM



Sunlight enters the collector, usually through a glass or plastic glazing and heats the absorber plate—a black metal or plastic surface that is in direct contact with channels through which air or liquid is circulating. The collector is designed to maximize heat flow from the hot absorber plate into the circulating air or liquid. To improve performance heat loss from the absorber plate is minimized by: 1) covering the collector with a transparent glazing to reduce convective and radiant heat losses; 2) surrounding the absorber with an insulated box and 3) coating the absorber plate with a selective surface to reduce radiant heat loss.

Flat plate collectors are generally mounted on a building or on the ground in a fixed position at prescribed angles that vary with the geographic location, collector type and the use of the collected heat. The optimum collector orientation

for space heating, or combined space and domestic water heating, is due south. Ideally, collectors should be tilted up from the horizontal at an angle equal to the site's latitude plus fifteen to twenty degrees for space heating and at an angle equal to latitude for water heating. If the angles differ somewhat from optimum, the system will still function, but may require a larger collector area.

Liquid-type solar collectors commonly use water as the heat-transfer medium. Antifreeze and corrosion inhibitors are common additives. The treated water carries heat from the collectors to an insulated storage tank. When heat is needed in the structure, it flows from storage through radiators, or air ducts, if a heat exchanger is used.

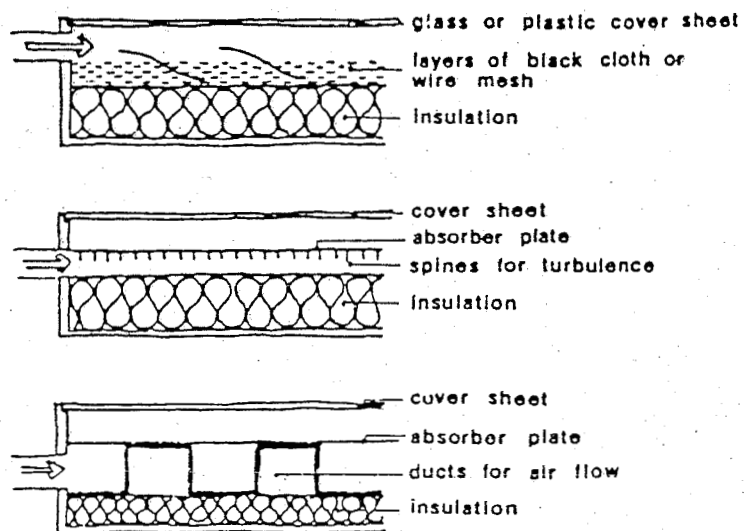
Air-type collectors are used in conjunction with rockbeds, water or eutectic salt storage. Warm air from the collectors flows directly into the building's air circulation system or indirectly into storage. When the rooms are sufficiently warm or when the building is unoccupied, the heated air is diverted to the storage bed, where more heat is stored with each pass through the collector. Rockbed temperatures are stratified: 140°F (60°C) on the top and 70°F (21°C) at the bottom. During the night or cloudy days, heat is removed from storage by circulating cool room air through a warm rockbed.

Air systems are relatively easy to integrate with a conventional forced air heating system found in most homes. Freezing, damaging leaks and corrosion that can occur with liquid systems are eliminated. However, duct length should be minimized to prevent excessive heat loss, and leaks are harder to detect.

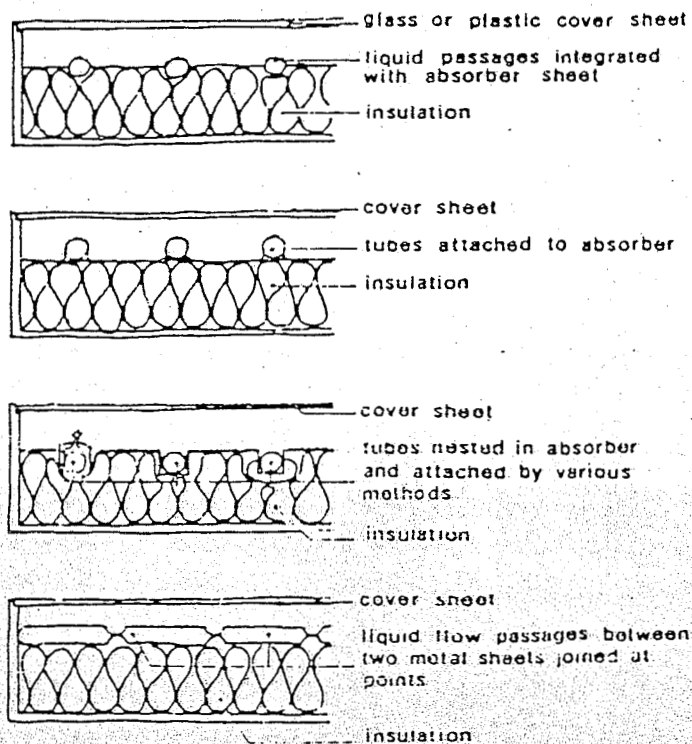
In either kind of system, a back-up system is needed when storage temperature drops below room temperature. The back-up may be a gas, oil, or electric hot water boiler, forced air furnace or an electric heat pump. The back-up system should be large enough to carry the total heating load during extended periods of cold cloudy weather. Figure 3.7-2 shows types of air and liquid collectors.

Figure 3.7-2 142

AIR AND LIQUID COLLECTORS, CROSS SECTION



A Air collectors



B Liquid collectors



The average household requires 250 square feet of collector for an active heating system. Installed costs average \$40-\$60 per square foot for the entire system with a total average cost of \$10-\$15,000. Self-installed systems are one half to two-thirds the price. Costs are somewhat less in new housing.

### Solar Cooling Systems

Active solar cooling is a developing technology for which there is a potentially large demand, especially in hot-humid climates where nocturnal cooling techniques are only marginally successful. DOE estimates for 1985 that 75 percent of all residential and commercial structures will have air conditioning units that will require as much electricity annually as electric heating systems.<sup>143, 144</sup>

General Electric Company's Solar Heating and Cooling Program Manager, William Terrill, predicts that new construction and retrofits will create a demand for over three million conventional air conditioning units in the residential market by the mid-1980s.<sup>145</sup> In the commercial market, sales of over three million tons of cooling capacity are predicted (with units ranging up to twenty tons).<sup>146</sup>

There are three basic cooling technologies: absorption chillers, vapor compression chillers, and adsorption or desiccant chillers. Solar energy can be used to totally or partially power any of these systems.

Traditionally absorption chillers have been fired with pressurized hot water or steam. However, solar heated water can be utilized. Regardless of the energy source, absorption chillers have two working fluids, a refrigerant and an absorbent which are circulated in a closed system. The refrigerant is usually water; the absorbent, lithium bromide. An ammonia/water-refrigerant/absorbent combination can also be used.<sup>147</sup>

An evaporator containing the refrigerant is located in the space to be cooled. The heat from the room vaporizes the refrigerant. The vapor goes to the absorber which contains the absorbent solution. The absorbent solution with the refrigerant is pumped to the regenerator, where the heat source is used to vaporize the water from the absorbent. The vapor is condensed and circulated to the room where the entire cycle is repeated.

Solar adapted absorption cooling is the most commercialized of the three cooling technologies. Conventional chillers were originally designed to operate efficiently with pressurized hot water or steam at temperatures between 220° (104.4°C) and 250°F (121.1°C). Now chillers are available that run on temperatures ranging from 170°F (76.7°C) to 195°F. This allows them to be used with selective-surface flat plate collectors. Efficiency and reliability are still problems at these lower temperatures.

However, conventional chillers can be used with collectors that produce water at higher temperatures. Collectors with cylindrical evacuated tubes or concentrating parabolic trough collectors are capable of achieving the temperatures necessary to power the conventional absorption chiller.<sup>148</sup>

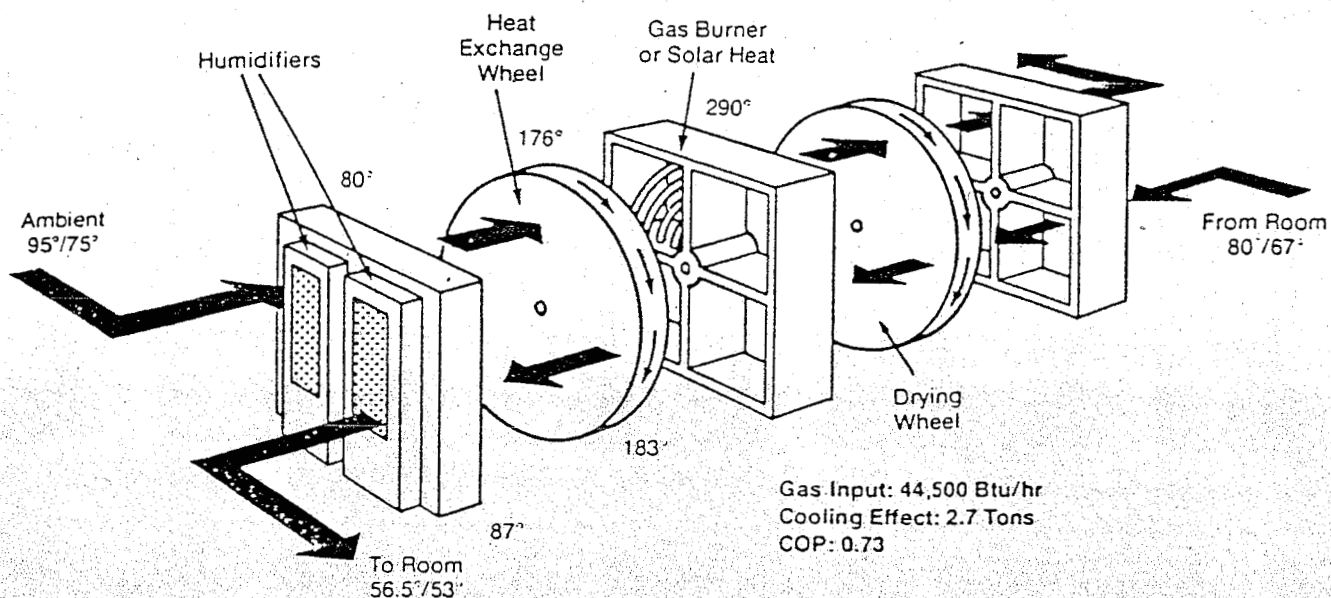


The typical air conditioning unit used today is the vapor compression type. Vapor compression units have a liquid refrigerant that is vaporized by the heat in the space to be cooled. A compressor condenses the evaporated refrigerant into a liquid, discharging heat to the environment in the process. Air conditioning units using an organic Rankine cycle engine are being developed. An organic Rankine cycle engine is a type of turbine that can operate with organic fluids (such as toluene) that are solar heated to temperatures below 550°F (287.8°C). According to Lennox Company, Rankine cycle solar cooling will be cost-effective for commercial and industrial users by the mid-1980s.<sup>149</sup>

Adsorption coolers blow room air over a drying wheel which contains a desiccant such as silica gel, slat crystals or zeolite. The air is dried and heated to 180°F (82.2°C). It is then cooled to near room temperature as it passes through a heat exchange wheel. Then the air is evaporatively cooled to 55° to 60°F (12.8°C to 15.6°C). Solar Energy is used to dry the desiccant. Desiccant systems have received little commercial attention primarily because they consume a large quantity of energy to operate the pumps and fans. Also, the system is large in comparison to the area it can cool.<sup>150</sup> Figure 3.7-3 illustrates an adsorption chiller run on gas or solar heat.

Figure 3.7-3<sup>151</sup>

AN ADSORPTION CHILLER



In summary, passive cooling will work in almost all climates in most new housing as well as some retrofit applications. Active air conditioning systems for retrofit residential use may be integrated into a total space cooling, heating, and water heating package by the mid-1980s. Active solar commercial air conditioning will be cost-effective before residential systems because commercial buildings pay twice as much for cooling energy and have large roof areas. Residential systems will probably never use the organic Rankine cycle vapor compression systems while commercial systems will tend to use absorption chiller units.

### Water Heating and Solar/Heat Pump Applications (3.7-3)

Solar water heating is a mature technology. Current research efforts are directed towards developing new designs and materials that can reduce costs. As with space heating, water heating can be accomplished with passive or active techniques. Passive designs circulate water without the aid of pumps by using either thermosiphon action or the water pressure from municipal supplies. Active methods circulate the water throughout the collector and to storage with the aid of pumps. Passive solar water heating is very cost-effective and will be used extensively by the mid-1980s.

The heat pump, often viewed as an energy conservation device, makes use of ambient solar-heated air in the natural environment to heat air or water. The electrical heat pump operates on the same principle as a "reversed" refrigerator. The compressor-driven evaporation and condensation of a refrigerant (such as freon) takes heat from air (or water) and pumps it into living space or hot water. Unlike the refrigerator in which heat is pumped from the interior of the insulated space (to chill food), a home or building heat pump draws heat from the environment into space or water for heating. In addition to the electrical heat pump, heat-actuated heat pumps have been developed which are fired by fossil fuels, such as natural gas.

Today, "reversible" heat pumps operate a standard refrigeration cycle in summer for air-conditioning, and reverse in winter to operate a heating cycle. Most units for household use are compressor-driven air-to-air electric heat pumps. A series of experiments dating back to the 1950s have been conducted on heat pumps using solar collectors to boost performance of the machines, since ambient temperatures below 45°F degrade the performance of the heat pump. With solar collectors, heat pumps can be boosted to operate with higher temperature air. Performance is measured by the COP (coefficient of performance) which is the ratio of the useful work delivered by the system to the units of energy needed to operate the heat pump. Typically, in moderate, southerly areas of the United States, heat pump COP's average 2-3, meaning that ambient air or water is supplying twice to three times the energy required to operate the device.

Electrically-driven heat pumps are also available commercially to heat water. These air-water heat pumps are available at costs ranging from \$600 to \$800, and compare favorably to solar hot water systems (costing up to \$3500 per installation) when electrical resistance water heaters are replaced. These small, efficient heat pumps were marketed briefly in the 1950s, but did not do well in an era of utility resistance and lower electrical rates.

Heat pump technology can be readily combined with solar passive designs, to heat air or water. Solar collectors can be used to boost performance in northern areas. As one recent analysis stated: "All the solar/heat pump concepts that we have identified have break-even solar collection costs considerably lower than the break-even solar collection costs of (solar heating combined with resistance heating)."<sup>152</sup>

The use of solar energy for pool heating is among the most cost competitive solar energy applications. Installed systems cost \$15-20 per square foot. Collector area should be at least 50 percent of the pool area or larger if the pool is used in the fall and winter. Pool system collectors are usually a simple unglazed absorber made of black plastic or rubber. Heat storage is provided by the water in the pool. The pool's pump and distribution system circulate the solar heated water.

### Solar Thermal Electricity (3.8)

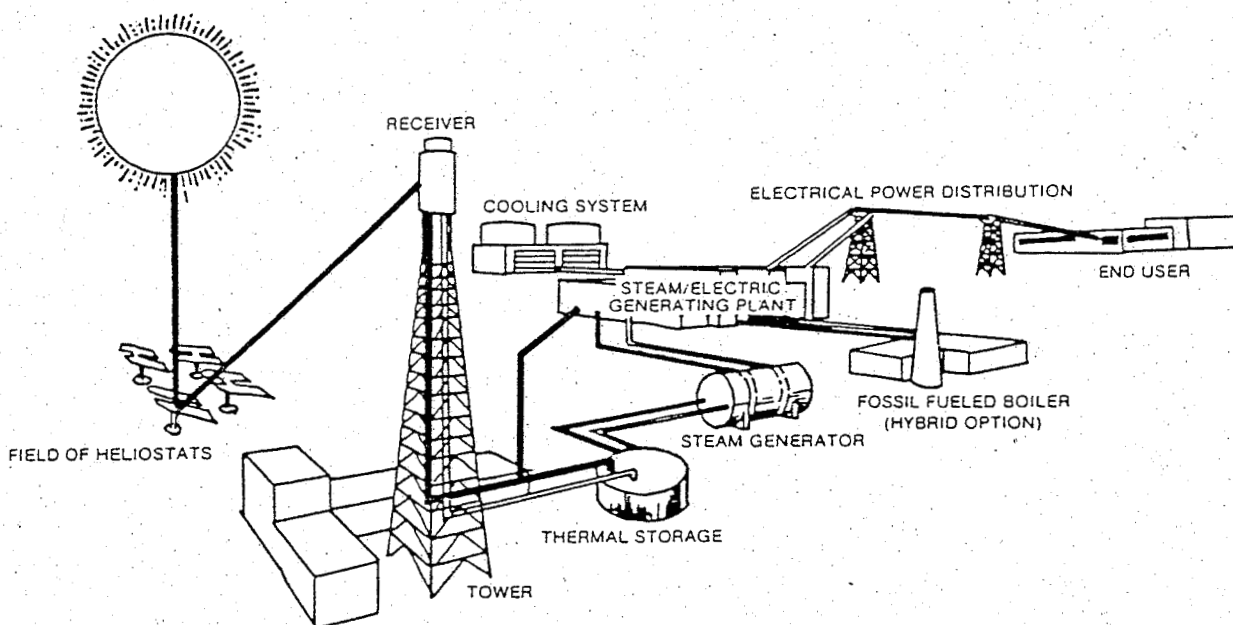
Solar thermal power systems use concentrating collectors to focus solar energy on a receiver. The sunlight can be concentrated so intensely that it is capable of producing temperatures to 1500°F (815.6°C). Water in the receiver may be boiled to produce steam for the generation of electricity or used for industrial process heat.

There are three basic approaches used in the design of solar thermal systems:

1) The central receiver concept separates the collectors from the receiver. Solar energy that is collected by double-axis tracking heliostats (flat mirrored tracking surfaces) is directed to a focal point on a central receiving tower. Figure 3.8-1 illustrates a solar central receiver system.

Figure 3.8-1<sup>153</sup>

#### CENTRAL RECEIVER SYSTEM



2) The solar "farm" concept uses many parabolic point focus collectors or parabolic trough linear collectors to create steam in a receiver located in each collector. The steam is then piped to a central generator.

3) The distributed receiver concept integrates the collector, receiver and generator into one unit. The collector configuration is either a single-axis or double-axis tracking parabolic dish. Sunlight is focused on a receiver at the focal point of the trough or dish. The generator is located in the unit creating a thoroughly decentralized, autonomous energy source. One prototype reportedly cost about \$3000/kW<sub>e</sub>.

Central receiver systems vary in size from the 100 kw<sub>t</sub> unit at the University of Genoa in Italy, the 400 kw<sub>t</sub> system at the Georgia Institute of Technology, the five MW<sub>t</sub> at Sandia Labs in Albuquerque, New Mexico, to the ten MW<sub>e</sub> system under construction near Barstow, California.<sup>154</sup>

In all of these systems a field of heliostats reflect sunlight to the central receiver on top of a tower. Water or liquid sodium pumped to the receiver is converted to steam and returned to the ground to drive a turbine generator.

Design parameters such as heliostat size, tower height, and area of land covered depend on the amount of electricity desired. The Barstow system covers 130 acres, with 1,818 heliostats.<sup>155</sup> Heliostats can range in size from four to ten square meters and the diameter of the field in which they are distributed is generally two to three times the height of the tower.<sup>156</sup> Generally three to six acres are required to produce one megawatt of electricity.

The installation at Barstow at a cost of \$140 million has dominated the federal solar energy research budget for the past few years. The cost of electricity produced will be \$10,000/kw installed capacity, or \$.60 to \$.90 per kilowatt hour.<sup>157</sup> However, the system at the Georgia Institute of Technology costs only one tenth of that amount (\$1000 per kw installed capacity).<sup>158</sup>

Frank Duquette, Manager for McDonnell Douglas Energy Program Development, states that the price per kilowatt hour will drop to \$.08 - \$10 per kwh when heliostats can be installed at \$6 to \$7 per square foot.<sup>159</sup> About 75 to 85 percent of the system cost is attributable to the heliostats.<sup>160</sup>

Current research at Sandia Labs and the Georgia Institute of Technology is exploring the use of different working fluids such as molten salts for use in receivers to work in conjunction with organic Rankine cycle engines as generators to improve efficiencies.<sup>161</sup>

Power towers are a more efficient way of using solar energy to produce electricity than are "farms" of concentrating collectors because the energy is transported as light rather than heat. Parabolic troughs focus sunlight in a line concentrating it up to 30 to 50 times.<sup>162</sup> The receiver contains a fluid in a glass-lined tube with a selectively absorbent surface that is located on the line of focus. It can reach temperatures of 572°F (300°C). Effective day-round performance requires that the collector track the sun on at least one axis. A variant of the parabolic trough collector uses tracking Fresnel lenses which are less sensitive to tracking errors than mirrored systems.

Parabolic trough applications include industrial process hot water, steam for industrial applications, or electrical production and space cooling with organic Rankine cycle systems.



Annual efficiencies in existing demonstration projects are only eight to thirty percent.<sup>163</sup> Nine percent of the U.S. end-use energy demand is for low temperature industrial process heat (less than 550°F (or 287.8°C)).<sup>164</sup> This is an ideal market for trough or other collectors. Parabolic trough collectors will probably be able to satisfy a good portion of this demand as production costs decrease and techniques for integrating the systems into industrial processes improve. Efficiencies of 40 percent can be expected by the early to mid-1980s. Other demonstration projects use linear concentrators to power irrigation and well pumps. Energy farms using hundreds of parabolic trough collectors are in the conceptual phase now.

Double-axis tracking parabolic dish collectors focus solar radiation to a specific point and are capable of concentrating the light up to 1000 times, producing temperatures of 1500°/1700°F (816.6° - 926.7°C). Because of exacting structural requirements these collectors are the least commercialized of the concentrating collectors.<sup>165</sup>

Applications include the production of process steam and generation of electricity via a traditional steam generator or an organic Rankine cycle engine.

General Electric Company is providing a total solar energy system for a knitwear company in Shenandoah, Georgia which consists of 100 collectors that will power a 400 kw Rankine steam engine and produce waste heat that will be used for 350°F (176.7°C) process steam. Jet Propulsion Laboratory is designing a one megawatt solar array for use at the community level.<sup>166</sup>

Omnium G, located in Anaheim, California, is the only company in the U.S. offering a commercially available parabolic dish collector. It is six meters in diameter and concentrates 1000 times. It produces 7.5 kw of electricity and waste heat can be used to produce 80 gallons (302.8 liters) of 180°F (82.2°C) water per hour.

Centralized systems can produce large amounts of energy in areas that receive high solar radiation and where other land use options are limited. However, decentralized collection systems have greater flexibility because they can operate in a modular fashion, adding or deleting units according to demand. Energy use at the site of production reduces transmission lossess when electricity is distributed over long distances. It enables the use of waste heat that cannot be economically transported over long distances. Use at the site of production reduces the ecological impact of energy production. Decentralized systems also reduce the vulnerability to large-scale energy shortages.

Another type of solar thermal electricity system is the solar pond. Salt gradient solar ponds are natural phenomena that can be artificially created and used as sources of heat, electricity, or both. A rule of thumb is that they can produce about one MW of electricity per 50 acres of pond area.<sup>167</sup> The optimal economics for electricity-producing ponds is probably between twelve and sixty MW, although small ponds at about five MW can be constructed without a large cost penalty. The ponds are inexpensive to construct compared to other energy sources. They are very

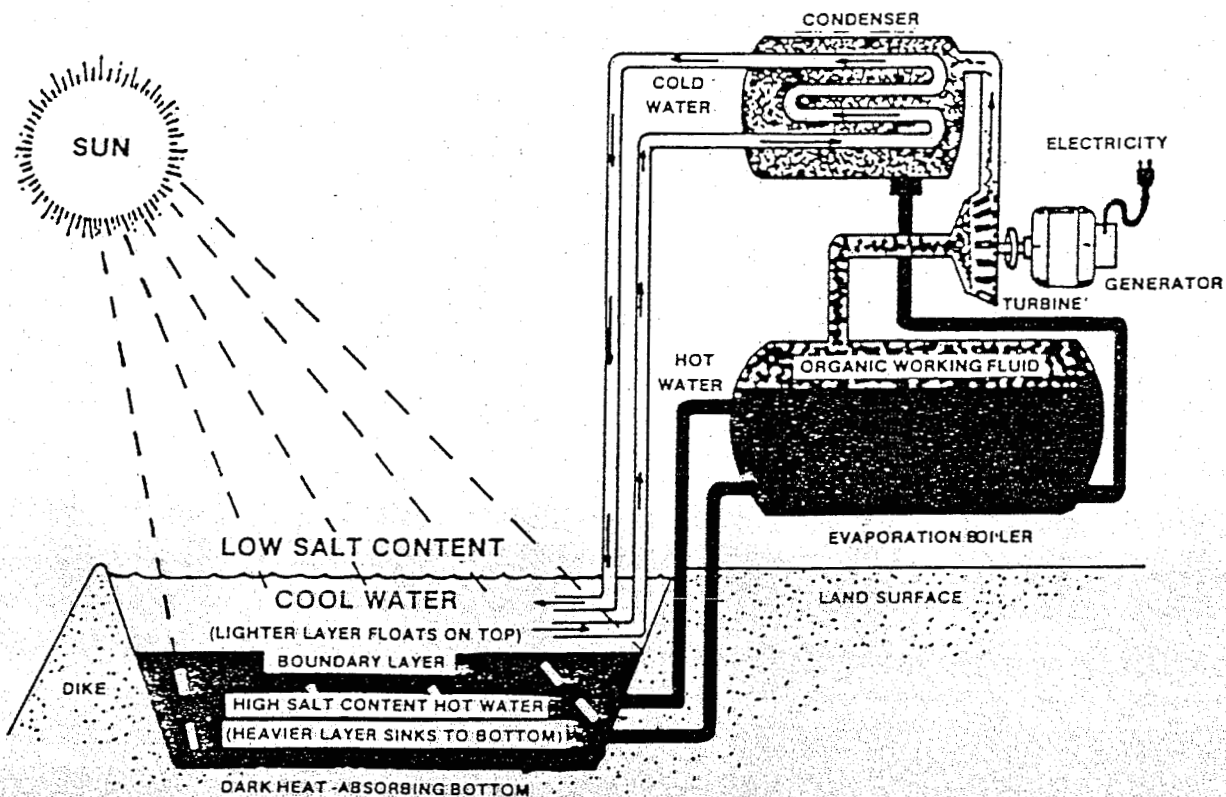


stable under conditions of environmental stress, require relatively short lead times for constructing, can start up power generation on only a few minutes' notice, are modular by nature, use a low-maintenance, proven technology to generate electricity, and present very limited environmental problems.

Solar ponds contain water in three layers of different densities.<sup>168</sup> The top layer contains the least salinity and density. The bottom layer is very saline and dense. Solar radiation penetrates the water where the light is converted to heat; the heat is then trapped in the bottom saline layer. It does not rise and escape for two reasons: first, it is trapped in the denser salty water; and second, the middle boundary layer (the density gradient or salinity gradient) acts as an insulating blanket. Consequently, the pond is both the solar collector and the storage medium. Figure 3.8-2 illustrates how solar ponds can generate electricity.

Figure 3.8-2 169

### SOLAR SALT POND GENERATING CONCEPT



The saline gradient boundary is the crucial layer in the pond since it is the only one that does not provide convection.<sup>170</sup> The top layer, exposed to air and wind, is affected by fluctuations in temperature and by the wind. Thus it loses energy because of convection. The bottom layer loses some heat to the ground by conduction at night and the temperature difference created in the saline layer initiates a small pattern of convection within the layer. The bottom-layer conduction losses are not large, but they do occur.

The saline gradient will form naturally if a pond is constructed of two layers, the lower one saline and the upper one fresh water. However, experimenters have found it more expedient to build the gradient into ponds by injecting layers of progressively less saline water over the top of a saline bottom layer. Layers that are disturbed tend to reform although the pond will lose some energy during the process.

The heat stored in the pond can be tapped in two ways. First, a heat exchanger can be run through the bottom layer of the pond and the heat used directly to condition space or water. This application requires minimal maintenance and is suitable for small ponds such as the 180-foot (54.9 meter) by 120-foot (36.6 meter) pond built by the City of Miamisburg, Ohio.<sup>171</sup> That pond is used to heat an outdoor swimming pool in the summer and an adjacent recreational building in the winter. Even at the end of February 1978, the pond (with ice on its surface) was 83°F (28.3°C) at the bottom. It is the largest direct heat application in the U.S. and cost Miamisburg \$70,000 to build. The liner and 1100 tons of salt required the biggest share of the capital expenditures. The total cost was \$3.20 per square foot.

Using solar ponds for thermal energy can be cost-effective for applications on small to medium scales. Such ponds might provide some of the heat required for multi-family dwellings, collections of single-family dwellings, or for large buildings such as commercial greenhouses or industries that use low - to medium - temperature heat. There is also a possibility that such ponds could run absorption chillers in the summer.<sup>172</sup>

The second way to tap the heat in a pond is to pipe the saline layer through an external heat exchanger, using the heated water in organic Rankine cycle engines to generate electricity.<sup>173</sup> This requires maintenance by trained personnel.

The Israelis were the first to experiment with solar ponds and began operating a 150 kw pilot solar electrical power station in 1979 at Ein Bokek on the Dead Sea. The plant collects heat in a rubber-lined, 70,000 square foot pond.

There are experimental saline ponds producing electricity in New Mexico, Nevada and Virginia,<sup>174</sup> but only one is currently being considered as precursor to commercial-scale production in the U.S. Feasibility and design studies, being coordinated by the Jet Propulsion Laboratory in California, have been funded by the Department of Energy, Department of Defense, State of California, Southern California Edison, and Ormat Turbines, Ltd. (the Israeli manufacturer of organic Rankine cycle turbines used at Ein Bokek), at a cost of \$650,000.

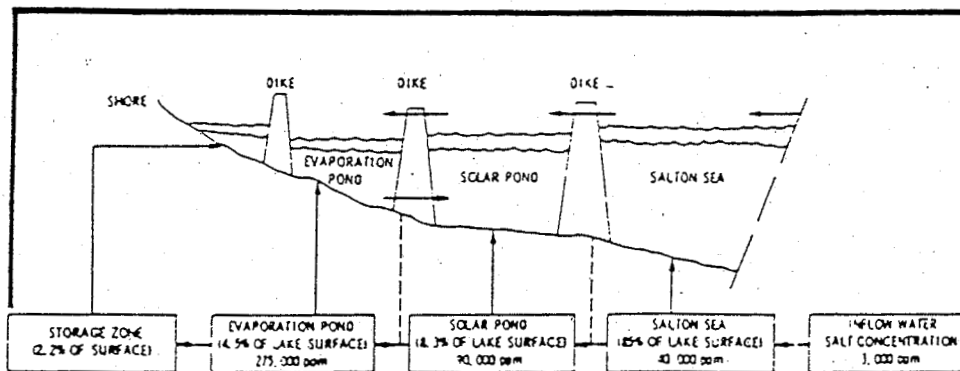
The studies are looking at several sites in the U.S. including the Great Salt Lake in Utah and the Salton Sea in the Imperial Valley in southern California. The Sea was created accidentally between 1905 and 1907 when heavy rains caused water from the Colorado River to flood the headgates of an aqueduct and fill the Salton Sink. By the time the flow was diverted years later, the Salton Sea had formed.<sup>175</sup> Over the years the Sea has become a wildlife refuge, popular sport fishing area, and sink for drained agricultural water. There is also a Naval base nearby.

The first pond to be built at the Salton Sea would cover about 250 acres and would generate five MW of electricity.

While the five MW plant was being built, feasibility studies would be done on building a 600 MW plant in twenty MW modules. The larger plant would require fifteen percent of the Sea's surface, or 50 square miles, (129.5 square kilometers) and would provide power for 500,000 to 1,000,000 people. Figure 3.8-3 illustrates how the Salton Sea solar pond would use a series of dikes to develop the necessary salinity and density gradients for electricity generation.

Figure 3.8-3 176

SALTON SEA SOLAR POND CONCEPT



Solar ponds show a great deal of promise, but like any other technology, there are trade-offs. Some of their limitations include:

1) The energy the ponds produce fluctuates seasonally and is subject to wind influence. The wind's impact can be minimized by windbreaks, screens, and other devices. However, seasonal fluctuation is natural, and pond output is lowest when heating requirements are highest.

2) For solar electrical ponds, there is a difference between peaking capacity and continuous operation capacity. The pond at Ein Bokek, for example, is rated at 150 kw, but only at peak production. The pond could sustain about 35 kw in summer and fifteen in winter at continuous operation.<sup>177</sup>

3) Since there have been few demonstrations of solar ponds, there will probably be many unanticipated problems. They are not likely to be serious enough to prohibit construction or prevent effective operation, but they could raise costs. For example, at the Miamisburg pool there has been some problem with corrosion of the copper heat exchangers in the pool, with settling of the sand used as foundation material, and with consequent leakage through the strained plastic liners.<sup>178</sup>

Solar ponds have several advantages as means of producing energy, however, including:

1) They produce no pollutants, no wastes, and use very little makeup water. The only obvious environmental hazard they present is the possibility of saline water leaking into underground water supplies.

2) The stored heat is available for electrical production at any time and on a few minutes' notice. This characteristic could be valuable for backup electrical capacity.

3) Because the storage is so accessible, solar ponds can deliver peak power ten or more times the power they provide in continuous operation, a feature that could be significant for peak power production.

4) The turbines used in saline ponds, specifically the Ormat models have demonstrated over some 30 million engine-hours (in applications that include fossil-fuel use) that they are extremely reliable and require very low maintenance. Forced outages at solar ponds have been at an average rate of two percent.<sup>179</sup>

5) Construction of saline ponds uses conventional earthworks techniques, without specialized personnel. This is important both for developing countries and for remote locations.

6) The ponds are most cost-effective in sizes from twelve to sixty MW, so large facilities would be built most economically in clusters of ponds. This modularity permits additions to capacity in small increments, as required.

7) Although the sizes of twelve to sixty MW are most cost-effective, ponds as small as five MW can be built with only small cost penalties. Consequently, the ponds can be constructed in many sizes depending on the application.

8) In case of attack, the ponds would have to sustain a direct hit before they were incapacitated. The modularity of the facility would allow partial operation of the plant even if some ponds in the complex were damaged. The most vulnerable parts of the system would be generating equipment, transmission lines, and heat exchangers.



### Ocean Thermal Energy Conversion (3.9)

The oceans are massive natural storage basins for solar energy. The difference in temperature between the sun-warmed surface of tropical seas, and the colder deep water, chilled by polar currents, represents a potentially enormous energy resource. Tapping this energy, however, requires complex and costly equipment of tremendous size. OTEC (Ocean Thermal Energy Conversion) is a concept for using oceanic temperature differentials to release stored solar energy to drive a turbine. In principle, this is no different from any other heat engine that extracts usable energy from a temperature difference. In practice, OTEC presents challenging engineering, economic and institutional problems.

In the 1920s French chemist, Georges Claude built a 22 kw generating plant at Matanzas Bay, Cuba. This pilot plant required about 80 kw of electricity to run its machinery. The existing technology of the time was simply too crude to permit Claude's daring design to produce net energy.<sup>180</sup>

At present, the most promising potential OTEC technology is a closed cycle, using a working fluid such as ammonia, freon or propane, which vaporizes when warm ocean water is pumped into an evaporator. The vaporized working fluid expands through a turbine, which drives an electrical generator. The vapor is then condensed by pumping cold water through a heat exchanger (condenser), and returned to the evaporator to begin a new cycle.

The plant would be moored to the ocean floor, and connected by underwater transmission cables to a power grid ashore. Some concepts envision floating industrial complexes, where OTEC electrical power would be used to produce ammonia, aluminum, hydrogen, or other energy-intensive products.

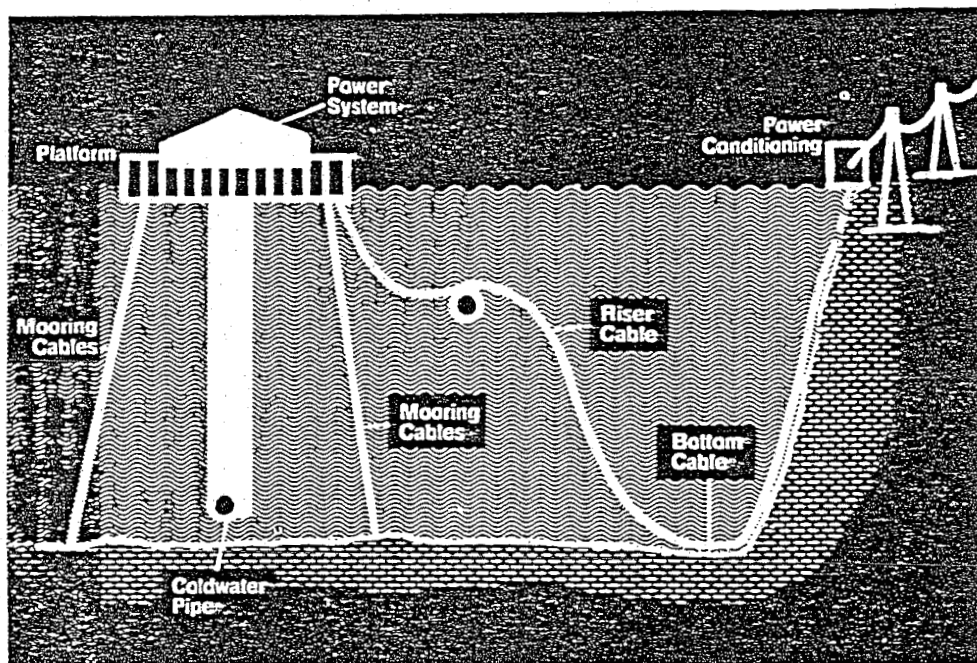
OTEC offers several clear advantages. Power could be generated 24 hours a day, in contrast to other solar technologies. Hence, OTEC could provide a constant source of baseload power, without the need for massive storage of electricity. OTEC plants would probably have minimal adverse environmental impacts. Figure 3.9.1 illustrates a conceptual OTEC system.

There are four major constraints on the location of an OTEC plant:

1. There must be a minimum temperature difference of about 38°F between the surface water temperature and the colder deep water. Moreover, this difference must exist within about 2500 - 3000 feet of the surface (otherwise the energy required to pump the heavier cold water to the surface becomes prohibitively great). On the other hand, the depth cannot be greater than about 6000 feet, due to the limitations of present mooring technology.
2. There must be relatively low-velocity currents.

Figure 3.9-1<sup>181</sup>

DIAGRAM OF AN OCEAN THERMAL ENERGY CONVERSION SYSTEM



3. There must be a minimal risk of storms (wind and wave action that would impose excessive stresses on the structure).
4. There must be close proximity to the market for the energy produced. At present, the maximum feasible length of the underwater power transmission cable is about 180 miles.

In general, the requisite temperature differentials are to be found within about 26 degrees of latitude north or south of the Equator. In U.S. territorial waters, the only viable sites are the Gulf of Mexico and Hawaii.<sup>182</sup> It should be noted that these are regions that already enjoy abundant solar energy that could be tapped with simpler, more decentralized technologies.

There are presently three principal technical problems which must be overcome if OTEC is to be commercially viable. These are biofouling, the engineering of the submarine power cable, and the construction and deployment of the cold water pipe.

Biofouling refers to the attachment of marine organisms to the vital heat exchanger surfaces, thereby reducing the rate of heat transfer and ultimately obstructing the flow of circulating water. Filters can be installed to keep larger animals such as mussels and barnacles out, but this cannot prevent the entry of microscopic organisms such as diatoms, bacteria and protozoans. Gradually a slimy film would form on critical surfaces, requiring down-time for cleaning, or potentially costly and environmentally hazardous measures such as chlorination.



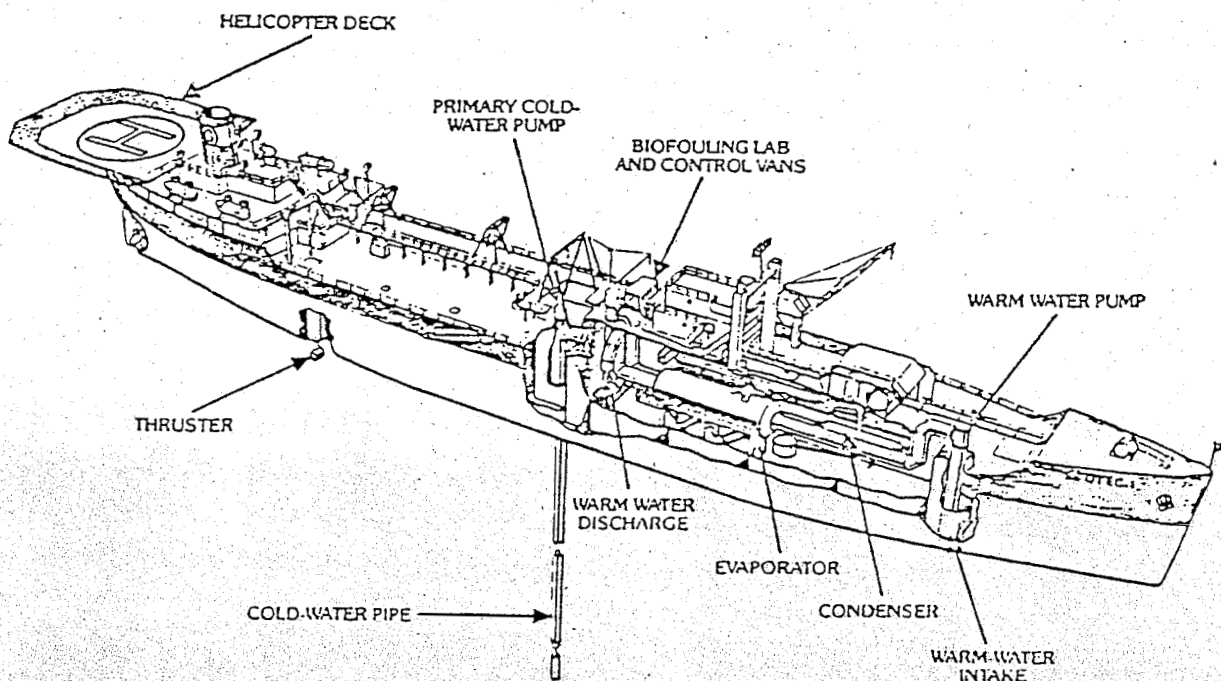
There are several problems associated with the design of the "riser" cable that would connect the OTEC platform with the submarine power cable on the ocean floor. It would be subject to great stresses due to platform motion and the chafing action of the seabed. With the present state of th art, the cost of underwater transmission lines exceeds \$1 million per mile. For an OTEC site distant from the shore, the cost of a single cable could equal the capital cost of the plant itself.<sup>183</sup> In addition, there is no known method to disconnect or reconnect the OTEC to the cable if the need should arise due to severe weather conditions.

Another major technical challenge is the cold water pipe. A 400 MW OTEC plant, for example, would require a volume of cooling water seven times the flow rate of the Potomac River. This would necessitate a pipe with a diameter greater than 100 feet. No pipe of this dimension has ever been constructed for use in a sea environment. The magnitude of the engineering feat has been described as "20 to 30 Baltimore Harbor Tunnel tubes, hanging vertically in the deep ocean."<sup>184</sup> Along with these specific problems associated with the deployment of an operating OTEC system, there are the traditional difficulties of working in a hostile marine environment: corrosion, maintenance and dependence on shore-based support facilities. A 400 MW OTEC plant would require pumps, motors and turbines larger than any now in existence. Experience with ship machinery indicates that major pieces of equipment require a periodic overhaul, typically lasting one to three months every two years or so.<sup>185</sup>

In order to gain operating experience with a baseline OTEC design, the DOE has modified a WWII tanker as a floating test bed, the SS Ocean Energy Converter, which is now operating off Hawaii. (See Fig. 3.9.2)

Figure 3.9-2<sup>186</sup>

THE S.S. OCEAN ENERGY CONVERTER



Major components of this prototype system include heat exchangers with over 44 miles of one-inch titanium tubing packed into a 13-foot diameter 55-foot long shell. The costly titanium is resistant to corrosion and strong enough to withstand frequent cleaning. Another crucial component being tested is the 2,100 foot long cold water pipe, consisting of three polyethylene tubes, each four feet in diameter, and weighted at the bottom. The \$41 million prototype will be used to evaluate heat exchanger technology, long-term biofouling and corrosion effects, cleaning techniques and environmental impacts on the marine ecosystem. With this data, DOE will have a basis for predicting future cost and performance parameters of full-scale OTEC systems.<sup>187</sup>

The economics of commercial OTEC systems are highly uncertain. Estimates of the cost of generating OTEC power vary widely, depending on the assumptions made by the estimator, the size and location of the proposed system, and assumed rates of inflation. Estimated capital costs of an OTEC plant have ranged from \$1000 to \$3700 per kw. A report on OTEC by the Office of Technology Assessment notes, however, that early commercial nuclear powerplants actually cost two to three times the amounts originally estimated.<sup>188</sup>

OTEC systems are, by nature, highly centralized and capital-intensive units. Because they operate on such a narrow temperature differential, they must move enormous volumes of water to generate useful amounts of power. As a result, they must be very large, and correspondingly vulnerable to enemy action, as well as the perils of the sea. As high-value symbolic targets, they might invite destruction, even in a conflict short of general war. For the cost of a single OTEC installation, a large number of dispersed, decentralized shore-base solar energy systems, using various technologies of greater maturity could be deployed far more quickly. DOE does not anticipate commercialization of OTEC before the 1990s, and other estimates have pushed this time frame well into the 21st century. These systems will require considerable further research and demonstration programs to prove their viability.

### Solar Photovoltaics (3.10)

The photovoltaic effect, whereby an electric current is produced when light strikes certain materials, was first reported by the French physicist E. Becquerel in 1839.<sup>189</sup> In 1905 it was explained in a classic paper by Albert Einstein. For many years the photoelectric effect was merely a scientific curiosity. The first practical application was the selenium photocell used in light meters.

Photovoltaic technology demonstrated to be reliable and effective; its biggest drawback today is its expense. It currently costs about \$7 to \$10 per peak watt (Wp) for modular systems, and \$15 to \$20 for installed systems. Today's cells are already economical to use in some remote locations such as isolated pueblos or channel buoys. By 1983, PV will be competitive with remote diesel generators. If manufacturers continue to meet the Department of Energy's schedule of price goals, solar cells may be economical to use on residences and in intermediate load-center applications such as schools and businesses by 1986, and in utilities' centralized systems by 1990.<sup>190</sup> In fact, it is estimated that central station PV systems will be cost-competitive for oil-fired, sunbelt municipal utilities as early as 1986. Table 3.10-1 gives the estimated costs of PV arrays to the year 1990 of the DOE National PV Conversion Program, as recently updated by Energy and Defense Project.

Table 3.10-1<sup>191</sup>

#### KEY MILESTONES FOR NATIONAL PHOTOVOLTAIC CONVERSION PROGRAM

	<u>Array price in 1980</u> dollars per week watt	<u>Production, rate peak</u> megawatts per year
End of FY 1977	11.0	—
End of FY 1978	7.0	—
End of FY 1982	1.4 - 2.8	20
End of FY 1986	.70	500
End of FY 1990	.14 - .42	50,000

During the 1954-58 National Space Program effort, the United States needed electrical supplies for its orbiting satellites. Solar cells that powered nearly all U.S. satellites were produced using the Czochralski method of growing crystals that had been perfected in the 1940s and 1950s. These cells were pure silicon, reliable and effective at more than ten percent efficiency, but cost around \$200 per peak watt. By 1961, costs went down to \$175 per watt.<sup>192</sup>

With the oil embargo of 1973, PV research efforts intensified. The federal government devised a program called the Low-Cost Solar Array (LCSA) Program in 1975 that funneled millions of dollars to researchers. In Fiscal Year 1980, federal funding amounted to \$160 million.<sup>193</sup> Private interests have also begun investing heavily in the technology; over \$200 million according to some estimates.

To lower costs, experimenters today are working to improve manufacturing techniques and to find new materials and designs that are more efficient or economical.

Once fully developed, photovoltaics will be flexible and diverse enough to use at different levels of centralization and could replace one Quad per year of primary fuel by the year 2000.<sup>194</sup> Budget-conscious homeowners may want simple flat-plate arrays of silicon panels that collect only the incident sunlight. Large businesses might choose arrays of gallium-arsenide cells that concentrate the sunlight to 500 times the intensity of the incident light (500 suns), that track the sun's path, and that use a special fluid to cool the solar cells and collect heat for space conditioning or for industrial processes. Utilities, on the other hand, might combine the two and use large arrays of flat-plate collectors for simple electrical generation along with a few arrays of concentrating collectors to provide heat for their own operations.

Whatever kind of cell is used, it will produce direct current. The current can be inverted to the 60-cycle alternating current that utilities require, and then transmitted throughout an existing grid. If the electricity is not needed when it is produced, it can be stored in various devices ranging from batteries to pumped water reservoirs.

During the day when electrical demand is highest and when production from photovoltaics is also highest, utilities may buy the power from dispersed producers and simply transmit it to where it is needed. At night, when both demand and PV production are down, the utilities may sell power from other sources, such as hydroelectric plants.

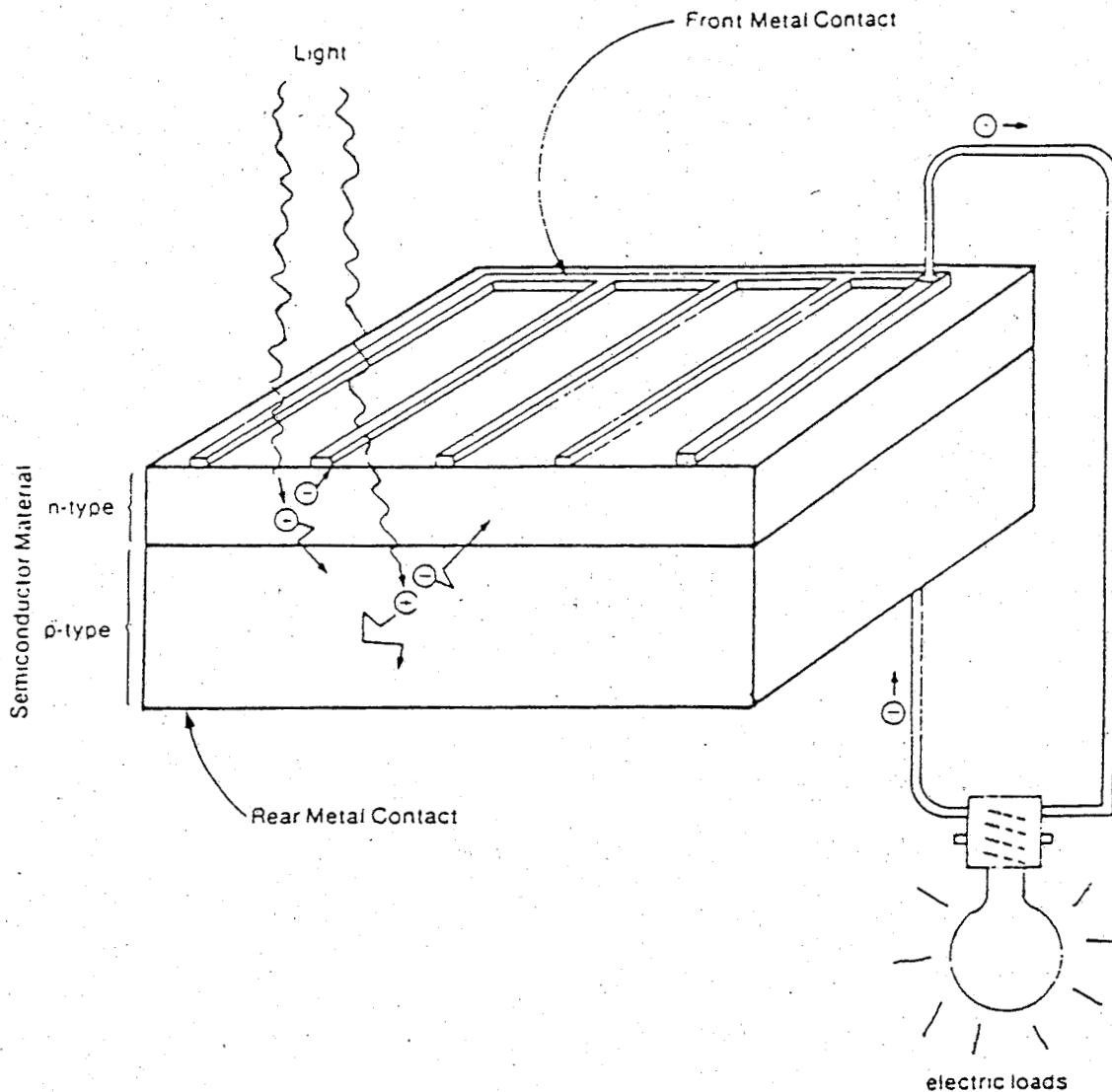
When sunlight strikes silicon, photons that are moving with more energy than 1.1 eV (electron volts) knock electrons out of the valence bonds that connect them to the neighboring atoms. The negatively-charged (n) electrons leave behind positively-charged (p) "holes" that neighboring electrons may move into. They in turn leave "holes" and if the flow can be made to move in a given direction, the electrons will flow in one direction and the "holes" in the other. Figure 3.10-1 illustrates a typical photovoltaic device.

A difference in potential is maintained between top and bottom halves of the cell. The boundary where the positively (p) and negatively (n) charged material meet is called the p-n junction. Junctions in silicon are made by introducing chemical impurities, or "dopants", into the material. One half is doped to have more electrons than can be bonded to the silicon, producing a p-type silicon, and the other half is doped to have fewer electrons.

The action at the p-n junction is complicated and not intuitively obvious, but the result is that light-stimulated electrons on the p side travel across to the n side. The flow is picked up by metal contacts arranged in a grid pattern on the n side. The electron flow (direct-current) moves down wires attached to the metal contact, is turned into work of some sort, and then the electrons flow back with a little less than their original energy down a wire to a metal contact plate on the p side, where they re-enter the cell to be excited by the sun.

Figure 3.10-1<sup>195</sup>

A TYPICAL PHOTOVOLTAIC DEVICE



Electron movement is slowed or stymied at crystal boundaries, so larger crystals, that reduce the number of boundaries, provide current more efficiently. Masses of smaller crystals are less expensive to produce, and non-crystalline material is even less expensive, so some approaches trade good crystals' efficiencies of eighteen percent for the much lower rates of six or seven percent for amorphous materials.

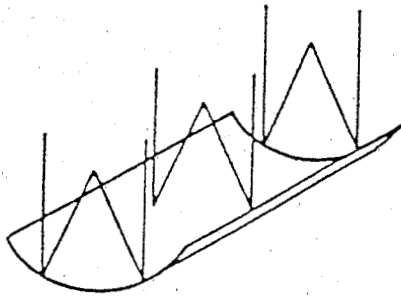
The amount of light captured is also a significant variable. Solar cells are commonly coated with nonreflective materials to reduce the amount of light that simply bounces off, and concentrator systems use mirrors or Fresnel lenses to focus more light on the cell. The concentrating systems' power is usually



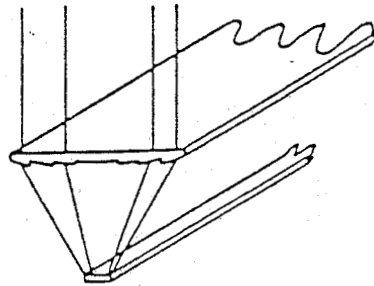
measured in "suns" (i.e., multiples of the normal incident sunlight). Some experimental systems produce 10,000 suns of concentration. Figure 3.10-2 illustrates several concentrator designs.

Figure 3.10-2<sup>196</sup>

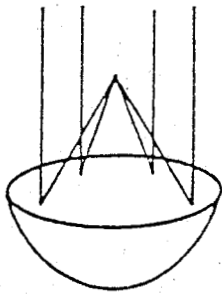
SAMPLE REFLECTING OR REFRACTING CONCENTRATOR DESIGNS



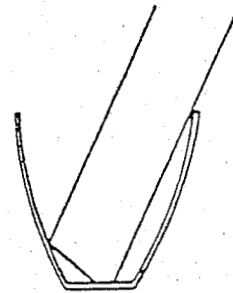
REFLECTING PARABOLIC CYLINDER



REFRACTING CYLINDRICAL FRESNEL LENSES



REFLECTING PARABOLOID



REFLECTING COMPOUND PARABOLIC CONCENTRATOR

Other approaches to capturing more sun utilize more of the light in the spectrum. Silicon's electrons require light moving with 1.1 eV before they are knocked out of their bonds. Up to a point, the electrons will be stimulated more by more energetic photons, but beyond a certain energy level the excess



simply produces heat in the cell. Therefore, the more energetic the photon, the more likely its energy is to be wasted. In 1972, Dr. Joseph Lindmayer developed the "violet cell" that can convert more of the high-frequency ultraviolet waves into electricity. Newer research applications combine different materials, each with a different energy threshold.

When PV systems are assembled, they contain several components. The individual cells, often round and about three inches in diameter, are packaged in groups of twelve to forty in flat protective boxes called panels by the industry and modules by the government. The panels are grouped into an array, which may be of any size, from the area covered by two or three panels to the size of a football field or larger.

To maintain their angle toward the sun, the arrays are supported by mounting racks. The racks may be stationary, or they may pivot so that the array can track the sun and catch the maximum light available.

The electricity generated must be transported by wires to a storage or distribution system. Storage may take many forms, from pumped-water reservoirs to arrangements of batteries or fuel cells.

When the PV system is connected to an established electrical grid, it requires a current inverter which changes the direct current to 60-cycle alternating current.

The baseline technology is still very expensive but has nearly reached its theoretical limits of efficiency. Research is now directed at reducing the cost of the silicon, finding less expensive manufacturing methods for silicon crystals, finding new useful forms of silicon, finding new materials, and trying new designs that reduce the amount of silicon needed.

The Department of Energy expects the next order of magnitude cost improvement for PV's to occur in manufacturing technique. Paul Maycock, Director of DOE's Photovoltaic Program has stated that costs can be halved just by automation once production volume warrants the capital investment.<sup>197</sup>

Current explorations into manufacturing focus on improving the growth of silicon crystals. The baseline technology in the Czochralski method (or CZ method) in which a seed crystal is suspended in a quartz crucible of molten silicon and is slowly drawn upwards, then allowed to cool. The crystal, which would otherwise grow with its grain at angles, grows straight because the forming cylinder is rotated slowly. This is a slow batch that process requires a new quartz crucible with every ingot because the crucible cracks in cooling. The cylindrical crystal is sawed into slices about 400 microns thick. They become the familiar circular three-inch solar cells after being cleaned, doped on one side, and imprinted with contacts.

The CZ process is expensive because slicing the discs reduces between 40 and 60 percent of the ingot to fine sand. Investigators are looking into replenishing the silicon in the crucible to produce longer cylinders; making cylinders of greater diameters; improving the sawing techniques; and recycling the silicon if it has not been contaminated.

Other investigators are exploring ways of making rectangular crystals that can be grown in ribbons continuously instead of relying on batches. Rectangular crystals would pack together more efficiently than circular ones, and would gain more electricity per unit module area.

In addition to silicon there are other materials that will work in solar cells if the cells are in concentrating arrays. Varian Associates in Palo Alto achieved in 1978 a 28 percent efficiency, the highest ever reported for solar cells, in an experimental arrangement that combined gallium arsenide and silicon cells to respond to different wave lengths in the spectrum. Varian's usual efficiency for its gallium arsenide concentrating cells is about seventeen percent. The advantage of gallium arsenide is that its performance is not as seriously affected as silicon's at higher temperatures.

Another new combination is cadmium sulfide and copper indium selenide. Boeing produced a cell using these materials with an efficiency of 9.4 percent. This is not far from DOE's goal of ten percent efficiency for thin-film devices. It is also a good example of the rate of progress being made in photovoltaics; the efficiency increased from 6.7 percent to 9.4 percent in less than a year.

Researchers are also developing new designs, such as concentrating arrays of thermophotovoltaic cells. These are more energy-intensive than the usual flat-plate systems because they require active cooling and sometimes tracking mechanisms to follow the sun. Thermophotovoltaic systems also sacrifice maximum efficiency at either their heating or generating tasks in order to achieve about a 30 percent overall efficiency at both.

Other new designs provide a photovoltaic roof shingle for homes (from ARCO), a multilayered sandwich of silicon wafers that are illuminated from the edge (expected to reach an efficiency of up to 30 percent), and cells of pure silicon that are not doped, but instead have the n and p material printed on the back in a pattern like interlocking fingers. This design is expected to reach twenty percent efficiency after some improvements are made; it has already reached fifteen percent.<sup>198</sup>

While researchers work on making photovoltaics more economical, the Department of Energy is building demonstration projects using baseline technology to show that photovoltaics work today. In 1979, the DOE spent \$27.5 million over three years to build systems under the Federal Photovoltaic Utilization Program (FPUP). The first 53 installments cost \$500,000 and were built for the Forest Service, the Navy's Material Command, the Indian Health Service, and the Tennessee Valley Authority, all at remote locations.<sup>199</sup>

One of the locations is Schuchuli, Arizona, an Indian pueblo of 96 people. The PV supply will provide them with 3.5 kw for lights in all houses and the community house, a washing machine, a sewing machine, a water pump, and fifteen small refrigerators.<sup>200</sup>

One PV installation that has received widespread notice is a 283 kw unit at the Phoenix Sky Harbor International Airport. At peak generation it will provide enough electricity to power 40 average homes in Phoenix.<sup>201</sup> It is being built by a team composed of Arizona Public Service Company, Motorola's Government Electronics Division, the City of Phoenix, and the Arizona Solar Energy Commission. It will use 7200 concentrator modules on 30 large arrays. The total array will require ten acres at the airport and will power half of the south concourse of a new airport terminal.

There are several major obstacles at present to the rapid commercialization of photovoltaics. These include a projected shortfall in the production of high-purity silicon crystal, the lack of ready capital for expansion of the industry, the threat of foreign competition for markets (Japan, France, Germany and Italy all have active PV research and development programs) and unresolved questions about the socioeconomic and environmental impacts of the rapid development of new technology.

A shortfall of silicon is the most immediate problem. New processes now being developed may not be ready in time to relieve the shortage. No governmental solutions have been offered to date, and silicon producers are reluctant to invest the massive amounts of capital required to assure production until they have a more solid indication of demand.

One of the best hopes of solving the silicon supply problem will be using a metallurgical grade instead of semiconductor grade. This approach has been incorporated into several research programs including Crystal Systems which has achieved a cost production rate of \$3 per kilogram. ARCO Solar has also proposed that silicon manufacturers produce a "solar grade" of silicon, which would be more pure than metallurgical grade silicon and less than semiconductor silicon.

Another major problem for photovoltaics is that producers won't scale up their manufacturing efforts until demand has been demonstrated; demand, however, depends on the low prices that mass production would bring. This natural pattern of development may be too slow to meet DOE's timetable. To change the pattern, one side or the other must be deliberately stimulated. Most observers suggest massive purchases by government, far in excess of what is currently planned.<sup>202</sup> For 1980, the Department of Energy is spending over \$4.5 million on new PV systems for federal building and facilities. Industry spokespeople are calling for \$1.5 billion, ten-year photovoltaic "Manhattan Project" as a way of developing the industry quickly.<sup>203</sup>

Other unresolved questions include the environmental problems of toxic substances created in cell manufacture and use, and the social impacts of the rapid development of the new technology. The DOE's Solar Energy Research Institute (SERI) is beginning to study environmental hazards, but little information has been available until recently because both materials and processes have been in such a state of flux.

While photovoltaics appear to be an environmentally benign technology, especially in comparison to the massive combustion of fossil fuels, there are possible adverse effects involved in the mining, refining, manufacture and ultimate disposal of photovoltaic cell materials.

Silica dust, for example has been associated with a chronic occupational lung disease, silicosis. The manufacture of silicon devices involves possible exposure to a number of hazardous chemicals (phosphine, boron trichloride, hydrochloric acid and hydrogen cyanide, among others).<sup>204</sup>

Arsenic and cadmium are two of the elements used in some advanced PV cell designs, and both are well known as toxic environmental pollutants. Fortunately, only small quantities of these metals are required, even for a massive expansion of PV technology. To ingest a toxic dose of gallium arsenide for example, a person would have to eat about 200 square feet of flat-plate arrays.<sup>205</sup> The long service life (up to twenty years) and encapsulation of PV cells would tend to limit the release of toxic substances into the environment, although there might be risks of occupational exposure in manufacturing.

The manufacture of PV cells is, itself, a highly energy intensive process. Under existing technology (the CZ method) approximately 7000 kwh is required to manufacture a cell with a peak output of one kw. This means the device must operate for about four years to "pay back" the energy consumed in making it.<sup>206</sup>

Although cheaper, less energy intensive methods for producing PV devices are being developed, a massive expansion of the industry is likely to require major inputs of energy from other sources. In the long term, of course, the goal should be to power the solar industry with renewable energy sources exclusively.

In addition to being energy intensive, the solar photovoltaic industry is presently labor intensive. Expansion of this technology is therefore likely to create jobs, many of them in trades and geographic areas now suffering from high unemployment. Although production of the devices may become increasingly automated, installation in onsite applications will probably remain a semi-skilled occupation allied to the conventional building trades (electrician, carpenter, sheet-metal worker, etc.). The PV industry must, however compete with the semiconductor industry for top research and engineering talent, and shortfalls of some critical skills might develop if the industry expands very rapidly.

Other barriers to photovoltaic development are institutional in nature and include such problems as restrictive building codes (although this seems less of a problem with PV than with solar thermal systems), and uncoordinated utility buy-back and interfacing programs.

Photovoltaics are ideally suited to residential or other on-site applications. A major question is storage. Remote locations will certainly require storage making the system more expensive but still competitive with diesel or other generators by 1982. The development of advanced batteries may bring down storage costs. This is a major goal of current DOE research. On-site locations that could be connected to the utility grid can take advantage of buy-back arrangements and use utilities' production power at night.

Other dispersed or small-scale applications might be private citizens' combining arrays for clusters of homes, utilities' using PV arrays on a neighborhood or district scale as load levelers, or using PV arrays for remote mechanical tasks, such as running irrigation systems. Over 90 percent of the harvested cropland in California is irrigated, and 98 percent of the irrigation pumps are electrically powered. A major disruption of the electrical power grid would be catastrophic for agriculture. The modular nature of PV systems makes them well-adapted to irrigation pumping. At the University of Nebraska, a 25 kw PV system has been used to irrigate 80 acres of corn and soybeans since 1977. The system operates ten hours per day, pumping up to 1,800 gallons per minute. During the winter, the electricity is used for crop drying. At present, research on direct current pump motors is being carried out at the Nebraska test facility. DC pumps would avoid the small but inevitable losses involved in inverting PV output to the AC required by conventional pumps.<sup>207</sup>



### Biomass Energy (3.11)

Biomass is a form of solar energy and is therefore a renewable energy source. Biomass may be defined as any form of plant matter, living or dead. The photosynthetic process allows plants to convert solar energy into chemically stored energy in the form of polymeric hydrocarbons (carbohydrates).

In comparison to other energy technologies biomass has a relatively low conversion efficiency (approximately one to two percent). Table 3.11-1 gives a rough comparison of energy efficiency ratings for biomass with other solar technologies.

Table 3.11-1<sup>208</sup>

#### ENERGY EFFICIENCY RATINGS

Biomass	1% - 2%
Solar Heating	40% - 90%
Photovoltaics	6% - 35%
Wind Electric	30% - 47%
Solar Thermal Electric	4% - 20%

However, biomass is somewhat unique because it is the only form of solar energy which directly converts and stores energy as a hydrocarbon. Coal, petroleum and natural gas are fossil forms of biomass created over long periods of time. Biomass, because of its low efficiency, requires large amounts of land to capture sufficient quantities of solar energy. Its unique storage and conversion properties, however, make it very attractive from an energy management point of view.

Because the U.S. has vast areas of land available for the growth of biomass and because many current agricultural and foresting practices produce high quantities of waste and residue materials, biomass appears to be a very significant source of energy. Various studies have estimated the biomass potential for the year 2000 to be between seven and twenty Quads.<sup>209</sup>

Most frequently used waste materials have been wood from the forest products industry, municipal solid wastes, agricultural processing wastes, and livestock manures. The forest products industry has for many years practiced biomass energy production. This is largely a result of the economic benefits of using by-product wood wastes in a combustor/boiler to produce process steam and frequently, cogenerated electricity. The key to the cost-effectiveness of these operations is in the hidden transportation cost. The transportation cost of the fuel is covered in the high value of the principal end product (i.e., lumber, paper, furniture, etc.) because using the waste materials actually increases the profit margin through reduced fuel bills to the manufacturer.

The current contribution of a biomass to national energy production is estimated



to be slightly less than two Quads ( $2 \times 10^{15}$  Btu per year), or just under one million barrels of oil per day. Nearly all of this energy is produced by the forest products industry.

Because of the high cost of fuel oil energy production from biomass has been expanding. The contribution of biomass is expected to expand to between four and eleven Quads over the next ten years.<sup>210</sup>

Residues from crops and forestry harvesting, although attractive because of their large volume, have not been widely used to date. High transportation and collection costs of these materials have made them non-cost-effective when compared with the cost of conventional fuels. These residues, however, have in the past two years become quite attractive to existing consumers of woody biomass. A case in point is the Eugene, Oregon Water and Electric Board (EWEB), a city-owned, public utility which has expanded its existing wood-fired electrical generating facility. Wood waste supply for the plant is based on locally available sawmill residues. Currently the EWEB is seeking fuel suppliers to guarantee supplies of forest slash in order to ensure additional fuel supplies for expansion of the power facilities at the lowest cost to their customers.

The concept of sustained yield energy farming, in which crops are grown exclusively for conversion to energy, is one which has received increasingly more attention. The economics of this type of biomass production/utilization are much more tenuous given the general low cost of competing energy supplies. In energy farming, the end product of energy produced must compete with the average cost of conventional energy. The current cost of competing fuels, however, has not proven high enough to justify a commercial venture at this time.

An example of cost-effective energy farming is that of growing grain to produce alcohol. The by-product of alcohol production is a high protein cattle feed. The cattle generate food for human consumption and their waste manure provides energy (when converted to methane gas) for process heat to fuel the distillery. Further, direct combustion of nonfermentable crop residues such as corn stalks is possible.

In addition to vast quantities of forestry residues and agricultural waste, there is a substantial amount of urban waste available for conversion to energy. These wastes are referred to as municipal solid waste (MSW) and sewage.

The energy potential from these waste streams has been estimated to be between one and three Quads per year. To date there have been numerous problems with waste-to-energy facilities associated with MSW. This can largely be attributed to the difficulty of handling this non-homogeneous material. A recent Office of Technology Assessment (OTA) report on MSW thoroughly examines these difficulties.<sup>211</sup>

In contrast to the problems of producing energy from MSW, sewage has for the past century been a significant contributor of energy for the purpose of operating municipal wastewater treatment (MWT) facilities. The use of anaerobic digestion for treating sludge from municipal sewage is widely practiced. A by-product of this treatment is the production of a methane-rich gas having about 60

percent of the heating value of natural gas. Anaerobic digestion is a biological fermentation process in which methane-forming bacteria decompose solid organic matter which release a gas (biogas) composed of carbon dioxide and methane. This gas is typically burned in a boiler or internal combustion engine with a generator. In most cases there is more gas available than required, but most of the excess is either used on-site or, more commonly, flared. While this is a very small quantity of energy (about 0.02 Quads), it is a reliable source that could play an important role in an emergency situation. This resource is currently underutilized, realizing only about 60 percent of its potential.

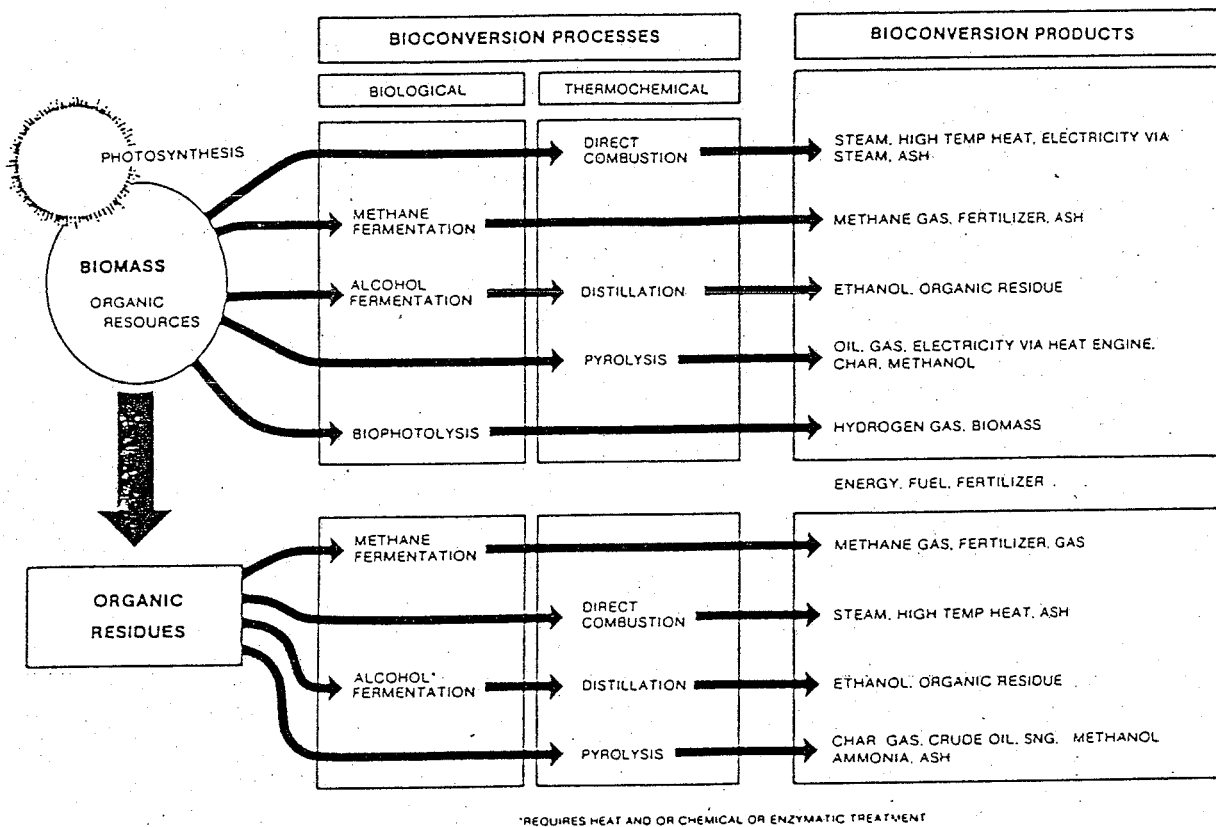
Beyond these land-based biomass resources from the forest, agricultural lands, energy farms, MSW and MWT, there are also aquatic biomass resources which have potentially much higher yields than the terrestrial resources. Aquatic resources fall into two very broad categories: 1) Fresh Water Systems, and 2) Oceanic Systems. Fresh water species such as algae, duckweed, and water hyacinths promise to approach photosynthetic rates of land-based crops like sugar cane, which exceed silviculture (forestry) production by as much as a factor of two to three. Ocean farming of species of giant kelp along the coast of California shows some promise, but current experiments have yielded limited results.

The most formidable barrier to the extensive use of the various biomass resources is the availability of reliable economic, off-the-shelf hardware to harvest, process, load, convert and utilize the energy. The energy type required or desired will often dominate the choice of conversion technology since different processes are required to deliver the desired energy type.

Figure 3.11-1 gives an overall perspective on the variety of feedstocks (biomass resources), conversion technologies (bioconversion processes), and energy and by-product end uses (bioconversion products) that are potentially available to the society from the utilization of biomass.

Figure 3.11-1212

BIOCONVERSION PROCESSES AND PRODUCTS



There are five basic technologies which fall into two basic conversion methods, that of thermochemical and biochemical. Thermochemical conversion of biomass is essentially the burning or high temperature degradation (conversion) of the material to release the stored solar energy from the complex organic compounds (polymeric hydrocarbons). The two methods for thermochemical conversion are direct combustion and pyrolysis.

Direct combustion is burning in the presence of enough air (oxygen) to convert all the chemical energy into heat. In pyrolysis or gasification, the other type of thermochemical conversion, the biomass is partially oxidized so as to give a resulting gaseous form of energy, pyrolytic oils and char (like "charcoal").

Direct combustion (DC) of dry biomass (50 percent moisture) is the most widely used and best developed of the conversion technologies. The energy products which are available from this thermochemical conversion process are high temperature

heat (400°F-2000°F) (204.4°C-1,093.3°C), steam and electricity via steam. The applications range from simple box stoves for residential heating to complex multistage steam turbine generators for electrical production. The economics of electrical generation by this method generally dictate that systems be larger than 200 kw installed capacity. The steam requirement for such power production is typically  $4 \times 10^6$  Btu per hour or greater depending on the outlet pressure from the turbine.

Direct combustion of biomass can also be done in conjunction with coal. Coal typically has five to ten times as much ash content as biomass but the heat contents of the two resources are reasonably close (8,000 Btu/lb. or 17,637 Btu/kg wood vs. 12,000 Btu/lb. or 26,455.5 Btu/kg coal). They are also similar in their solid fuel combustion characteristics.

The limitation of direct combustion is that it cannot be easily adapted to many current energy uses such as internal combustion engines (ICE), gas turbines, or gaseous and liquid fuel combustion equipment. To adapt woody or dry biomass to operate such devices it is necessary to convert the solid fuel to gaseous state. This is accomplished through a thermochemical process known as pyrolysis which is defined as the thermal decomposition of the solid fuel in the absence of oxygen.

Pyrolysis is a natural part of the solid fuel combustion process and in a typical fire the long orange flames are the combustion of the pyrolysis gases when they contact air. These combustible gases are principally carbon monoxide and hydrogen with traces of methane and other hydrocarbons. Typically systems use a limited supply of air to assist in the partial combustion of the fuels.

These units which use air are typically referred to as air-fed gasifiers or simply gasifiers. These gasifiers produce a gas with a heating value typically ranging from 100 to 200 Btu per standard cubic foot (scf) (147.9-295.9 Btu per standard cubic meter) or about ten to twenty percent the heating value of natural gas which is principally methane gas.

Variations on this basic principal range from pure oxygen-fed pyrolysis units producing 300-500 Btu/scf (443.8-739.6 Btu per standard cubic meter) gas to steam-fed gasifiers which require internal heating elements to sustain the process. The producer gases from these systems can be further processed through a reforming catalytic conversion.

These gasifiers are commonly referred to either as pyrolysors or medium Btu gasifiers (MBG). MBG's require much more sophisticated controls, equipment and engineering than the low Btu gasifiers (LBG's). Typically LBG's are well suited to small-scale applications while MGB's require rather large-scale applications with subsequent large fuel requirements.

Battelle Pacific Northwest Labs has given a comparative analysis of Low Btu gas and Medium Btu gas:

Development of biomass gasification and indirect liquefaction technologies are midterm development activities because

these technologies are not expected to have a substantial impact on U.S. energy supplies for ten to twenty years. Biomass gasification technologies can be divided into processes which produce a low Btu gas and those which produce a medium Btu gas.

Low Btu gasification technology is commercially available for most types of biomass feedstocks. Many of these commercial processes are based on low Btu coal gasification technologies and the gas produced can best be used as fuel for supplying process heat, process steam or for electrical power generation.... The versatility of low Btu gas is limited and its use is subject to the following limitations:

1. The low heating value of the gas usually requires that it be consumed on or near the production site in a close coupled process.
2. Substitution of low Btu gas for natural gas as a boiler fuel usually requires boiler derating and/or extensive retrofit modifications.
3. The high nitrogen content of low Btu gas precludes its use as synthesis gas for most chemical commodities which can be produced from synthesis gas.

Medium Btu gas (MBG) offers the following advantages over low Btu gas:

1. Boiler derating is usually less severe when substituting MBG for natural gas than when substituting low Btu gas for natural gas.
2. MBG can be transported moderate distances by pipeline at a reasonable cost.
3. MBG is required for the synthesis of derived fuels and most chemical feedstocks and commodities which can be produced from synthesis gas.

The major disadvantage of MBG is that its production by conventional means requires the use of an oxygen-blown gasifier which is expensive to operate due to the cost of the oxygen.

If thermoconversion of biomass is to achieve its maximum potential for augmenting existing U.S. energy supplies in the midterm, the following two points will have to be considered:

1. Barring serious coal production constraints, biomass conversion will have to be cost competitive with synthetic fuels produced from coal.



2. Thermochemical biomass conversion must have an impact on the availability of liquid fuels and chemical feedstock supplies as well as supplementing gas for heating purposes.

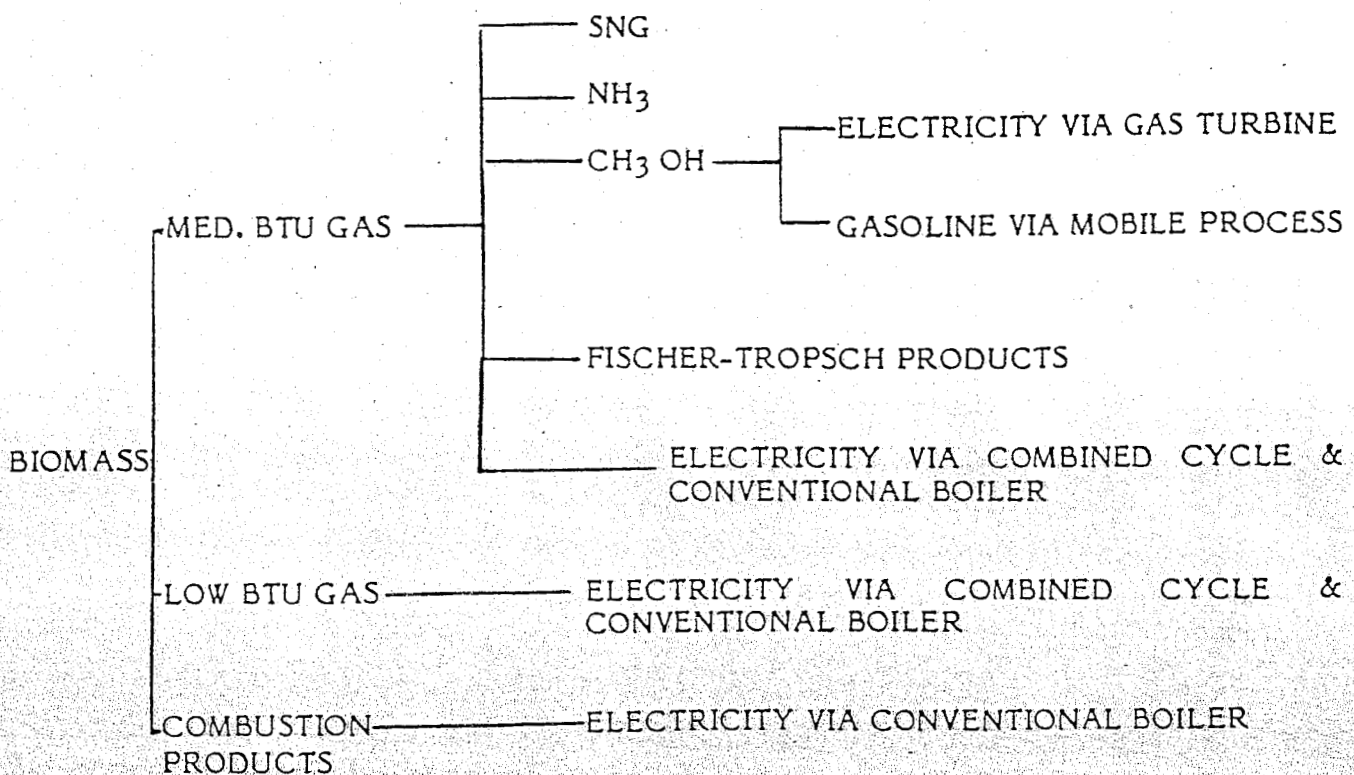
Biomass has two potential advantages over coal. First, biomass is a renewable resource and coal is not. Second, and more important from a thermo chemical conversion stand point, biomass is more reactive than coal. It has the potential for gasification at lower temperatures, without the addition of oxygen, to produce MBG. There are activities also directed toward improving the competitiveness of biomass gasification through the use of catalysts and unique gasification reactors to produce directly specific synthesis gases for the production of ammonia, methanol, hydrogen, and SNG. Success in these efforts could eliminate the necessity for external water gas shift or methanation reactors when producing these commodities.<sup>213</sup>

The California Energy Commission and the University of California, Davis, have successfully demonstrated that LBG can effectively be used in existing boilers using natural gas.<sup>214</sup>

Figure 3.11-2 shows the versatility of a MBG process. The drawback for such a process is primarily the large quantities of biomass required to justify such an operation and the additional requirements for pure oxygen and/or steam as opposed to air for oxidation.

Figure 3.11-2<sup>215</sup>

THERMOCHEMICAL CONVERSION PATHWAYS FOR FUELS FROM BIOMASS





A typical MBG facility would require an input of about 1,000 tons per day (tpd) (907,184.7 kg/day) biomass. This could be supplied by a city of 1,000,000 population and would produce about 50,000 gallons (189,270.6 liters) of methanol per day (about 25,000 gallons or 94,635.3 liters gasoline equivalent). Assuming a yield of six dry tons per acre-year with a ten year crop rotation, a 1,000 tpd (907,194.7 kg/day) plant would require about 1,000 square miles (2,590 square kilometers) of forest to sustain such a facility. This would require an area with a minimum transportation radius of about 30 miles (48.3 kilometers) and more than likely 50 miles (80.5 kilometers) would be necessary. The 1,000 tpd feedstock requirement is dominated by the economy of scale for equipment, especially compressors which are required to operate at about 30 atmospheres.

Many schemes have been suggested for conversion of biomass to other products. These range from methane gas, commonly referred to as SNG (synthetic natural gas), crude oil, gasoline, charcoal and many combinations of these fuels.<sup>216, 217</sup> Typically, a higher reaction temperature maximizes the producer gas output from a given biomass feedstock. The lower the reaction temperature, the more pyrolytic or crude oil generated from the process.

From an economic viewpoint both direct combustion and low Btu gasification appear to be competitive even with regulated natural gas prices. Medium Btu gasification and its numerous by-product capabilities do not appear to be competitive with the current cost of imported oil or with the projected cost for MBG from coal.

Current successful applications of direct combustion and to a more limited extent LBG, are confined to operations in which the feedstock is a part of a forestry, agricultural or municipal processing facility. In this case, the feedstock is either a waste or a residue which must be disposed of or removed from the facility. This results in a fuel which is either free or for which a credit can be taken because of cost incurred for hauling the waste to a dump or transporting the residue to a land disposal site.

Biochemical conversion of biomass refers in general to biological processes which rely on microorganisms. The primary and most widely used biological processes for energy conversion of biomass are anaerobic (in the absence of air) fermentation processes which rely on specialized microorganisms. It is, however, possible to produce hydrogen gas from water and sunlight by photosynthetic microorganisms. A system has been reported which uses a nitrogen-fixing, blue-green algae.<sup>218</sup>

This process has been termed Biophotolysis. Hydrogen is removed from the water when the blue-green algae are stressed. This stress is induced by creating a condition of nitrogen starvation. This creates a "...sustained catalytic decomposition of water by sunlight."<sup>219</sup> The economics of this process are not well established, but it does not appear to be feasible in the near future.

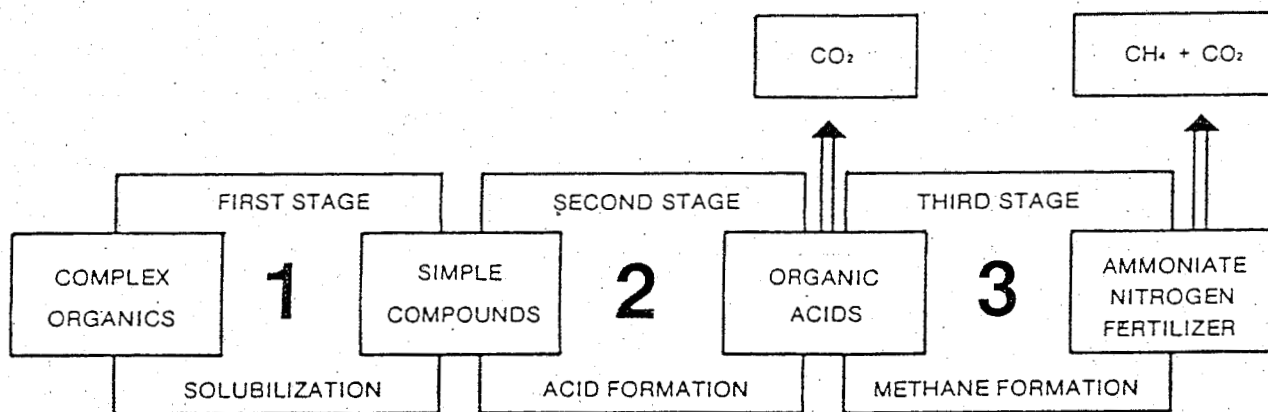
The biological conversion technologies which are currently in use are all fermentation processes. These processes are all anaerobic and are likely to be the predominant method available for this conversion.

There are two types of fermentation processes useful for conversion of biomass to energy. These are methane fermentation (also known as anaerobic digestion) and alcohol fermentation.

Methane fermentation (anaerobic digestion) has been widely used as a part of municipal sewage treatment. Microorganisms decompose organic matter. The resulting gas from this decomposition is referred to as biogas and is a MBG of 500-700 Btu/scf (739.6-1,035.5 Btu/square cubic meter). The biological production of methane is a very complex process wherein cellulose and other complex organic materials (proteins, carbohydrates, fats, etc.) first go through an enzymatic transformation. The solubilized organics are then converted by other bacteria into organic acids which in turn form hydrogen and carbon monoxide as a part of their metabolic process forming methane and carbon dioxide. The methane bacteria are strict anaerobe (oxygen is toxic) and require careful temperature control for reliable, sustained yields. Figure 3.11-3 shows this process.

Figure 3.11-3<sup>220</sup>

METHANE FERMENTATION (ANAEROBIC DIGESTION)  
A THREE STAGE PROCESS



The bacteria are strict anaerobe and prefer mammalian body temperatures although they are adaptable in a range of 10°C to 60°C. Typical large tanks have been used to insure ideal conditions in sewage treatment plants.

Alcohol fermentation or ethanol production is a very old process that has been primarily practiced and refined for the purpose of producing beverage alcohols. First a sugar or starch material is ground or mashed so that a yeast fermentation can proceed. Only a simple sugar can be fermented so that starches must undergo an enzymatic treatment and cooking to form simple sugars which the yeast can then convert to alcohol. In a second step the alcohol must be concentrated through distillation to remove the water since the fermentation process can only produce an alcohol concentration of fourteen percent. Successive distillation steps can produce pure 99.9 percent ethanol. This is accomplished through an energy intensive process of removing water by the heat of vaporization.

Typically two columns are used to produce a 95 percent alcohol water. A specialized third column is used to produce 99.9 percent ethanol. Ethanol has about two-thirds the heating value of gasoline on a gallon-for-gallon basis. Ethanol can be burned in a solution of water as low as 50 percent, but 80 to 90 percent are preferred for combustion purposes.

Ethanol has about twenty percent greater heat value than methanol. Ninety-nine percent solutions can be blended with gasoline as a fuel stretcher and octane enhancer. Ethanol can achieve higher efficiency than gasoline when used in a modified ICE since it can be used at higher compression ratios without the knock problems associated with gasoline. Fermentation has distinct advantages as well as disadvantages over the thermochemical conversions. Table 3.11-2 gives a comparative analysis of fermentation versus thermochemical conversion technologies.

Table 3.11-2<sup>221</sup>

FERMENTATION COMPARED TO THERMOCHEMICAL CONVERSION

	<u>Fermentation (F)</u>	<u>Thermochemical (TC)</u>
Conversion efficiency biomass to energy	Depends on biodegradable material	Conversion to heat and electricity are superior to F process
Quality of energy produced	Very high, alcohol and methane gas	More expensive to duplicate alcohol, but electricity is best quality for cost
Biomass feedstocks	Accepts wet biomass readily but poor in cellulose and ligno-cellulosic materials	Must be @ 50% moisture or severely affects Btu/lb. but will burn lignin readily
By-products	Fertilizer and/or livestock feed, fiber, etc.	Ash and charcoal
Environmental concerns	Water pollution potential, odor, solid waste disposal greater than TC	Air pollution, carcinogenic materials from ash and creosote, solid waste much less than F

The most important aspects of fermentation are its abilities to produce high quality energy. Methane fermentation (anaerobic digestion) yields a MBG which is distinctly different from the pyrolytic MBG. This gas (as implied by the process name) yields a methane-rich gas as opposed to a carbon monoxide and hydrogen gas that is created in the pyrolysis process. Rather than a synthesis process, the methane-rich MBG needs to have carbon dioxide removed to become SNG or

pure methane. This process has been demonstrated and is commercially available at several locations.<sup>222, 223</sup> Typically the biogas which is methane-rich MBG can be used on site in very slightly modified equipment which has been operated on natural gas. The biogas is composed of 50-70 percent methane and 50-80 percent carbon dioxide with a trace of hydrogen sulfide and other gases.

Methane fermentation works best with wet biomass feedstocks of high cellulose content. It does not work well with hard to degrade materials like woody biomass which contain high percentages of lignin or lignin-bound cellulose. These hard to degrade materials generally require some form of pretreatment including combinations of heat, grinding acid or alkaline hydrolysis.

Methane fermentation can contribute to both energy production and provide useful by-products like animal feed and fibers. Typically this process has been applied to municipal sewage treatment (MST) as a stabilization process for the heavy solids (sludge) found in urban wastewater.

Methane fermentation has been widely researched, demonstrated and promoted for extracting energy from livestock manures in confined operations.<sup>224,225</sup> This process has also been widely applied to municipal solid waste through the extraction of the gas from old landfill sites.

Alcohol fermentation or ethanol production is an age old process that has received a high degree of engineering development for the production of beverage alcohol. Although the engineering for beverage alcohol and the economics of its operation have been increasingly refined over the years and the level of sophistication is very high, the process for making alcohol for fuel use needs some additional development to improve energy efficiencies and to lower cost for competition with other fuels.

Currently available technologies for ethanol production rely heavily on starch or sugar crops as a feedstock. These feedstocks fall into several categories. These include the following list:

1. Energy Crops: These crops are grown specifically for conversion to energy. This is not widely practiced now, but it appears to be on the increase on a small scale for farm production and use.
2. Excess Agricultural Crops: These are the grain stockpiles of the Midwest which currently provide the bulk of feedstocks for fuel alcohol production.
3. Agricultural Residues: These are those crops and residuals left in the field. Manure would also be included in this category since it is commonly returned to the land as a soil amendment. Most of these feedstocks are high in cellulose which would require special pretreatment. A notable exception to this would be fruit waste from regions such as Florida, South Texas, California, Washington, and Oregon. These wastes are sugar and can be readily fermented to ethanol.

4. Agricultural Process Waste: These are the waste and residues from processing facilities such as canneries, fruit packing houses, creameries, milling operations, etc. There are a variety of feedstocks from these facilities ranging from easily fermentable resources like fruit-packing waste to more difficult substrates like cheese whey and finally to cellulosic and lignocellulosic materials like cotton gin trash and stalks.
5. Municipal Solid Waste: These are urban wastes which are for the most part cellulosic and lignocellulosic materials. The heterogeneous nature of this feedstock has made it one of the most difficult to convert.
6. Wood: This resource is a lignocellulosic material which is subject to the same restraints discussed under "Agricultural Residues."

Because of the chemical similarity in the fuels, methanol (wood alcohol) is frequently compared with ethanol (grain alcohol). Methanol can be synthesized through the thermochemical gasification of biomass, coal, natural gas or other hydrocarbon fuels. Ethanol can also be synthesized from hydrocarbons via a thermochemical process utilizing ethylene either as a by-product in petroleum distillation or from the synthesis of natural gas.

Ethanol via fermentation of biomass and methanol via MBG gas synthesis from biomass will compete for the same resources if one assumes that cellulosic hydrolysis technology is a near term option. There is considerable professional disagreement whether biomass methanol will be cheaper than biomass ethanol from the cellulosic feedstocks.

Table 3.11-3 gives DOE projections for alcohol production from biomass resources in the U.S. Table 3.11-4 describes a number of feedstocks immediately available for ethanol production, and Table 3.11-5 gives those feedstocks that are potentially available for ethanol production.



Table 3.11-3226

PROJECTED MAXIMUM ALCOHOL PRODUCTION  
FROM U.S. BIOMASS RESOURCES

Biomass Feedstock	(Billion gallons per year)							
	1980		1985		1990		2000	
	Ethanol	Methanol	Ethanol	Methanol	Ethanol	Methanol	Ethanol	Methanol
Wood	23.5	86.3	21.8	80.2	20.2	74.2	25.8	95.0
Agricultural residues	9.1	33.4	10.3	38.1	11.3	41.5	13.1	48.1
Grains:								
Corn	2.3	---	2.1	---	0.9	---	---	---
Wheat	1.2	---	1.4	---	1.6	---	2.0	---
Grain sorghum	0.4	---	0.3	---	0.3	---	0.3	---
Total Grains	3.9	---	3.8	---	2.8	---	2.3	---
Sugars:								
Cane	---	---	0.2	---	0.7	---	0.7	---
Sweet sorghum	---	---	0.2	---	3.0	---	8.3	---
Total Sugars	---	---	0.4	---	3.7	---	9.0	---
MSW	2.2	8.6	2.3	9.2	2.5	9.9	2.9	11.6
Food processing wastes:								
Citrus	0.2	---	0.2	---	0.3	---	0.4	---
Cheese	0.1	---	0.1	---	0.1	---	0.2	---
All Other	0.2	---	0.3	---	0.3	---	0.3	---
Total processing wastes	0.5	---	0.6	---	0.7	---	0.9	---
Total	39.2	128.3	39.2	127.5	41.2	125.6	54.0	154.7

Based on the following biomass-alcohol conversion factors: Wood and agricultural residues - 173 gal. methanol per dry ton, 47 gal. ethanol per dry ton, Corn - 2.6 gal. ethanol per bushel, Wheat - 2.7 gal. ethanol per bushel, Grain sorghum - 2.6 gal. ethanol per bushel, Sugars - 136 gal. ethanol per ton, fermentable sugars, MSW - 100 gal. methanol per dry ton, 25 gal. ethanol per dry ton, Citrus waste - 107 gal. ethanol per dry ton, Cheese waste 95 gal. ethanol per dry ton, Other food processing wastes - 90 gal. ethanol per dry ton.



Table 3.11-4227

**BIOMASS FEEDSTOCKS IMMEDIATELY AVAILABLE  
FOR ETHANOL FUEL PRODUCTION**

Biomass Feedstock	Percent of total that is available to be converted to ethanol	Quantity available		Net feedstock cost <sup>1</sup> (including co-pro- duct credits) per gallon of ethanol	Million gallons per year ethanol
		Million dry tons	Million bushels		
Cheese whey	30	0.9	—	\$0.22	90
Citrus waste	30	1.9	—	0.30	210
Other food wastes	50	1.7	—	0.50	150
Corn	7	1.3	70	0.63	180
Grain sorghum	7	.3	13	0.60	30
Total		6.6			660

<sup>1</sup>1977 dollars.

Notes: This table shows the quantity of ethanol that could be produced from currently available biomass without (i) diverting to the production of energy crops, or (ii) necessitating any change in USDA land set-aside or diversion policy to take account of grains raised for ethanol production.

The table indicates immediate feedstock availability for production of 660 million gallons of ethanol annually, at a weighted average feedstock cost of \$0.60 per gallon ethanol. The grain feedstocks represent only 3 to 7 percent of existing corn and grain sorghum stocks, and consist principally of distressed and substandard material. Thus, all the feedstocks shown in the table can be regarded as "waste" materials.

Table 3.11-5228

**BIOMASS FEEDSTOCKS POTENTIALLY AVAILABLE  
FOR ETHANOL FUEL PRODUCTION**

Biomass Feedstock	Material potentially available for ethanol production		Net feedstock cost <sup>1</sup> per gallon of ethanol	Production potential, mil- lion gallons per year ethanol
	Million dry tons	Million bushels		
Cheese whey	0.9	—	\$0.22	90
Citrus waste	1.9	—	0.30	210
Other food wastes	1.7	—	0.50	150
Corn	16.0	640	1.10	1,660
Grain sorghum	2.7	110	0.98	280
Sugar Cane	2.6	—	1.52	150
Wheat	11.4	420	1.36	1,130
Municipal solid waste (MSW)	43.0	—	0.20	1,100
Total				4,770

<sup>1</sup>1977 dollars (including co-product credits).

Notes: This table shows the quantity of ethanol that could be produced if: (i) USDA eliminates all future set-aside and diversion programs, and all existing grain land is brought into productive use; and (ii) cane sugar surpluses and 50 percent of all municipal solid waste (MSW) are converted to ethanol. No new or marginal cropland is assumed to be brought into production, nor are agricultural residues, wood residues, or sweet sorghum potential included.

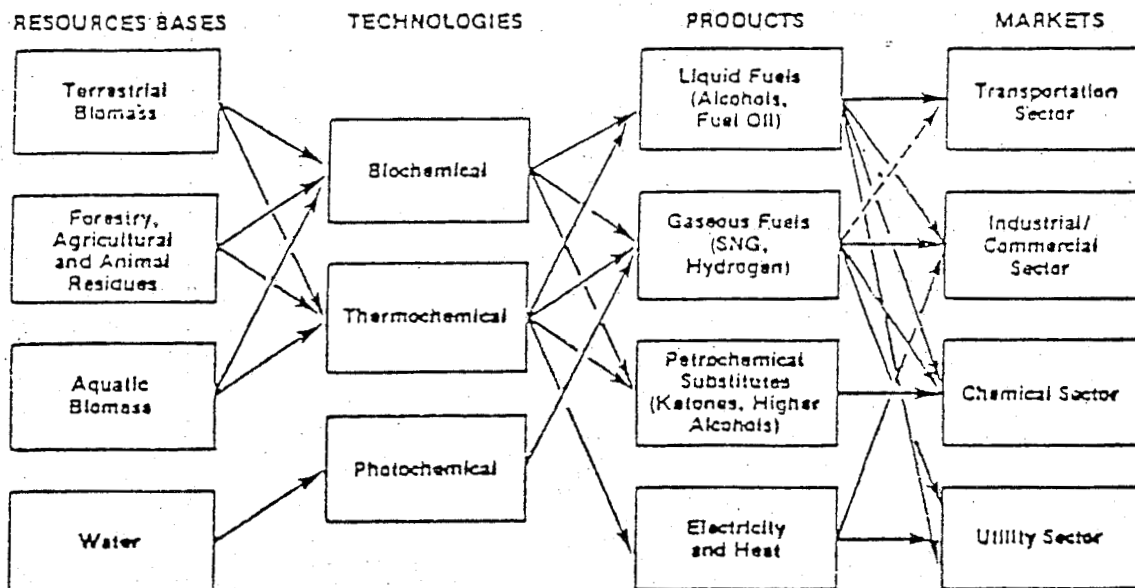
The table indicates immediate feedstock availability for production of 4.3 billion gallons of ethanol annually, at a weighted average feedstock cost of \$0.91 per ethanol gallon. Of this, 1.1 billion gallons comes from wheat, which may be judged too expensive (\$1.35 per gallons ethanol), and another 1.1 billion gallons comes from MSW.

There is considerable competition and disagreement over which biomass resource should be used with which technology to give which type of energy. To this already complex matrix of choices there are two other factors to impose: The first of these is economics, and in conjunction with economics is the competing use of these resources to produce chemical feedstocks rather than energy.

Figure 3.11-4 provides a graphic overview of biomass resource bases, technologies, products and markets, and Table 3.11-6 compares and contrasts the various biomass conversion processes.

Figure 3.11-4<sup>229</sup>

FUELS FROM BIOMASS



With the possible exception of direct combustion, all of the conversion technologies are either in a state of rebirth from previously abandoned technologies as is the case for gasification and methane fermentation, or they lack from being proven, field tested, reliable systems as is the case for cellulosic ethanol and methanol synthesis.

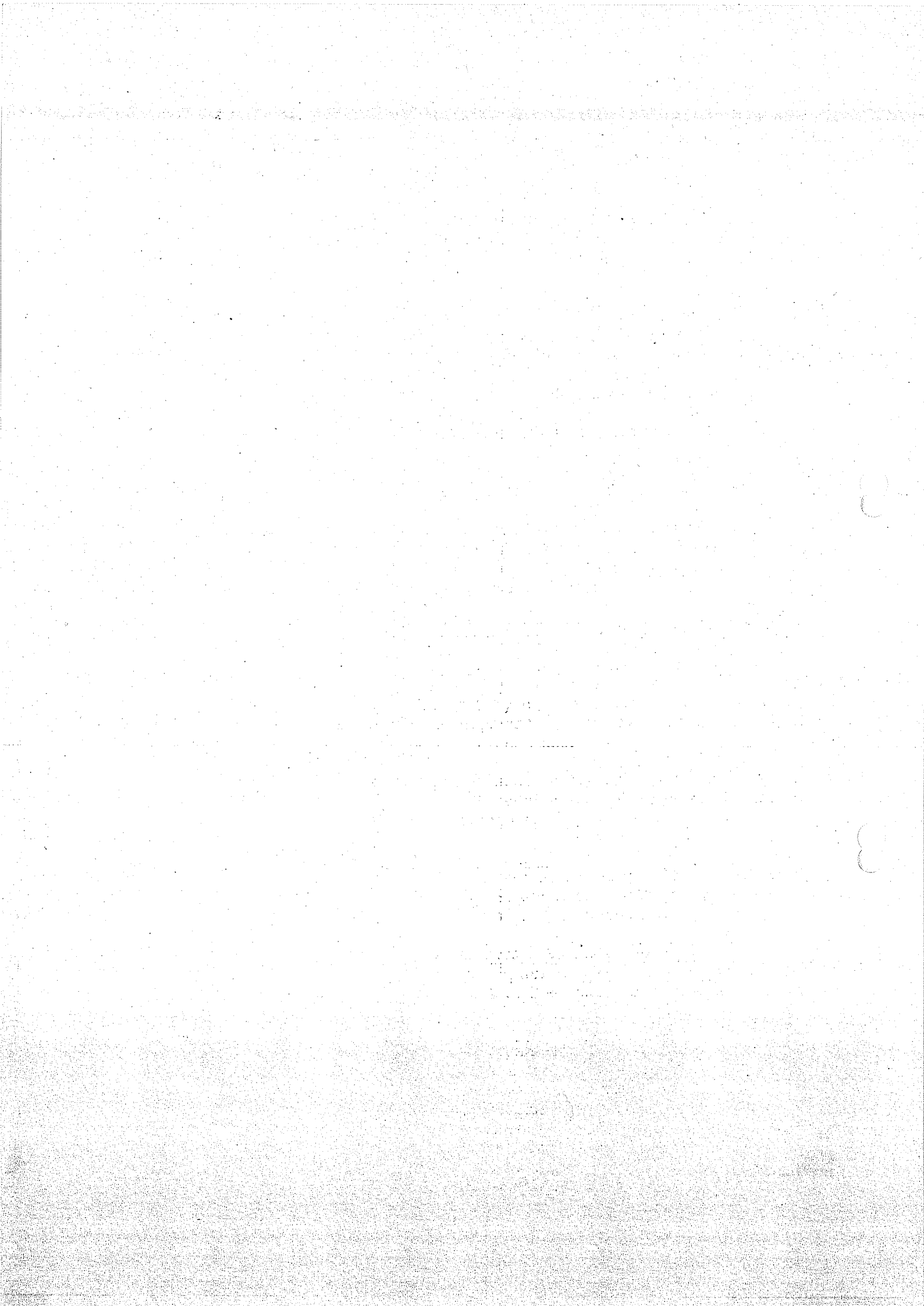


Table 3.11-6<sup>230</sup>BIOMASS CONVERSION PROCESSES

<u>Process</u>	<u>Biomass Inputs</u>	<u>Output</u>	<u>Overall Efficiency (%)</u>
Direct combustion	Dry <sup>b</sup>	Steam, electricity	65-70 15-25
Cogeneration	Dry <sup>b</sup>	Steam and electricity	65-70
Gasification, with oxygen	Dry <sup>b</sup>	Medium-Btu gas	40-60
		Methanol	35-50
Gasification, with air	Dry <sup>b</sup>	Low-Btu gas, Steam <sup>c</sup>	50-85 65
		Electricity	10-20
		Pyrolysis	Pyrolytic oil, char, low-Btu gas
Anaerobic digestion	High moisture (sewage sludge, aquatic biomass, etc.)	Medium-Btu methane gas	35-50
		Electricity	5-10
Ethanol fermentation (followed by distillation)	Sugars (sugarcane juice, molasses, hydrolyzed cellulose, etc.)	Ethanol	30

<sup>a</sup> Based on the percentage of biomass input (higher heating value) converted to fuel (or steam), less the required internal fuel needs of the conversion process.

<sup>b</sup> Up to 50% maximum moisture allowable without drying (e.g., wood chips, MSW, field-dried agricultural residue).

<sup>c</sup> Steam generation with low-Btu gas exhausting from a gasifier in a conventional oil or gas boiler (close-coupled gasification) would allow much higher efficiencies, approaching those of direct combustion.

The following general statements can be made regarding the current status of the technologies discussed thus far:

1. Direct Combustion (DC) is currently economic with some limits on the amount one must pay for fuel. It is very clear given the current instability in the price of oil that long term contracts for biomass fuels at higher than average petroleum fuel cost is probably a good investment. The conversion technology is well established. The next technological breakthrough for this particular area would be in the harvesting, transportation and marketing of fuels like forest slash and agricultural residues which have heretofore not been marketable as fuel. As the price of imported oil and synthetics affect the petroleum markets, marginal fuels like slash will become attractive; but there is a great need for reliable harvesting equipment and techniques.
2. Low Btu Gas (LBG) air-blown gasifiers are a reborn technology which have in the past achieved moderate levels of sophistication capable of sustaining petroleum-starved countries during wartime. Although competitive in price with conventional fuel (even regulated natural gas), gasifiers are not typically competitive with DC systems. They also suffer greatly from a lack of longterm operation and subsequent proof of reliability. Their small scale, versatility and portability suggest a successful future beyond the capability of DC systems. This appears to be especially true in applications like off-road vehicles, for farm use and for the portable generation of electricity.
3. Medium Btu Gas (MBG) oxygen/steam-injection gasifiers are limited because of their large through-put requirements, i.e., 1,000 tpd (907,184.7 kg per day) or greater. Like the LBG air-blown systems they suffer from lack of reliability testing. These will probably not be competitive in the near term (1985) with conventional fuels and will not necessarily compete with their likeness in the coal synthetics arena. Clearly, if they cannot be downsized from the 1,000 tpd (907,184.7 kg per day), they will not be able to compete for the same resource which will be used for cellulosic fermentation systems some of which appear to be coming on line in the pre-1985 period.
4. Methane Fermentation (MF) with by-product credits for refeeding effluent to cattle as a replacement for alfalfa, MF using current sewage treatment technologies appears to be competitive with regulated natural gas on operations with 100,000 head and larger. Since nearly

75 percent of the animal populations in confinement are on farms with less than 1,000 head, there is a critical need to commercialize a low-cost nonconventional system. This appears to be occurring in the dairy industry where payback periods of seven to ten years are acceptable. Covering of anaerobic lagoons also appears attractive since these structures release biogas to the atmosphere. The rebirth of this technology from its abandonment after WWII in Germany and France has yielded new applications of reliable, low-cost systems to the farm. In agricultural canning and packing operations these systems could compete with ethanol facilities. These systems can also complement ethanol facilities. Their near term application on farms is imminent. Of crucial concern here are the on-farm energy use patterns which are as yet poorly understood. The use of ICE/generator sets will prevail in the small scale (1,000 head) situations.

5. Alcohol Fermentation (AF) Although not economic without subsidy, the current subsidy makes these facilities very economic with returns on investments running in excess of twenty percent. Current reliance is on grain and to a limited extent sugar feedstocks. The production of this high grade motor fuel can play a significant role in stabilization of agricultural production as well as providing an exclusive fuel to support that production. This new industry will see the greatest economic growth in the coming near term because of its popularity. The promise of cellulosic conversion technologies is essential to avoid both food versus fuel issues and net energy concerns. Cellulosic technologies appear to have a chance of success in the near term. Their production costs, however, will probably need an initial subsidy. The small scale nature of this technology gives it a distinct advantage over methanol synthesis via MBG from the same or similar cellulosic feedstocks.

To realize the four to five Quads ( $10^{15}$  Btu per year) of biomass energy that could be realized in the near term, there is a massive need for capital investment. The \$1.4 billion provided by the Energy Security Act is encouraging but insufficient to provide what is needed to make a transition to commercialized biomass technologies.

Current motor gasoline consumption is roughly 108 billion gallons per year. Capital investment in alcohol fermentation is roughly \$1.00 to \$1.50 per million gallons (\$.26-\$.40 per million liters) per year capacity. To achieve a two percent goal as suggested by the Office of Technology Assessment, it would require an investment of about \$2-\$3 billion.



## Geothermal Energy (3.12)

Geothermal energy occurs as a result of radioactive decay deep within the earth and internal tectonic activity. Geothermal "hot spots" capable of yielding the energy equivalent of 1.2 trillion barrels of oil lie untapped in the western U.S. and parts of the Gulf Coast according to the U.S. Geological Survey (USGS). In its second national assessment of geothermal resources, the USGS estimated that the upper portion of the earth's crust contains 32 sextillion Btus of heat energy, 6.4 sextillion of which are harnessable "under reasonable assumptions of improvements in technology and economics."<sup>231</sup>

Three different types of geothermal resources interest electrical energy developers. The most extensive geothermal resource in the U.S. is in the form of hot dry rock. According to the Department of Energy, hot dry rock resources are "geologic formations at accessible depths which have abnormally high heat content but contain little or no water." Extraction of usable energy from these formations would require a heat transfer fluid such as water to be circulated through the rock. Though the extent of usable hot dry rock resources in the U.S. is very large (possibly as large as 32 million Quads, with thirteen million Quads at temperatures higher than 150°C) DOE doubts that it will contribute substantially to domestic energy supplies for some time to come.<sup>232</sup>

The next most plentiful are geopressured hydrothermal resources which are hot water aquifers containing dissolved methane. These aquifers are trapped under high pressure in deep sedimentary formations along the Gulf Coast of the United States. Three forms of energy are derivable from these resources: thermal, kinetic, and dissolved methane. Data on geopressured hydrothermal aquifers comes from nearby petroleum operations, and points to large reserves particularly in a wide belt stretching along the Gulf of Mexico from Mexico to Mississippi, and in two areas between northeastern Texas and Florida. More information on the number, location, size, permeability, and methane content of the aquifers is necessary to know whether such reserves are economically exploitable. This information is currently being gathered.

Least plentiful, but already in use in many parts of the world, are convective hydrothermal resources. These are systems of hot water and steam, heated by relatively shallow masses of hot rock, and trapped in fractured rocks or porous sediments overlain by impermeable surface layers. These systems are classified according to whether they produce steam or liquid. Rare, "vapor-dominated" (dry steam) reservoirs are used for generating electricity. "Liquid-dominated reservoirs outnumber vapor-dominated reservoirs by about twenty-to-one among known hydrothermal resources. Steam from these reservoirs can be separated from the liquid and passed through turbines to generate electricity.

The Department of Energy has described how geothermal resources are distributed across the United States:

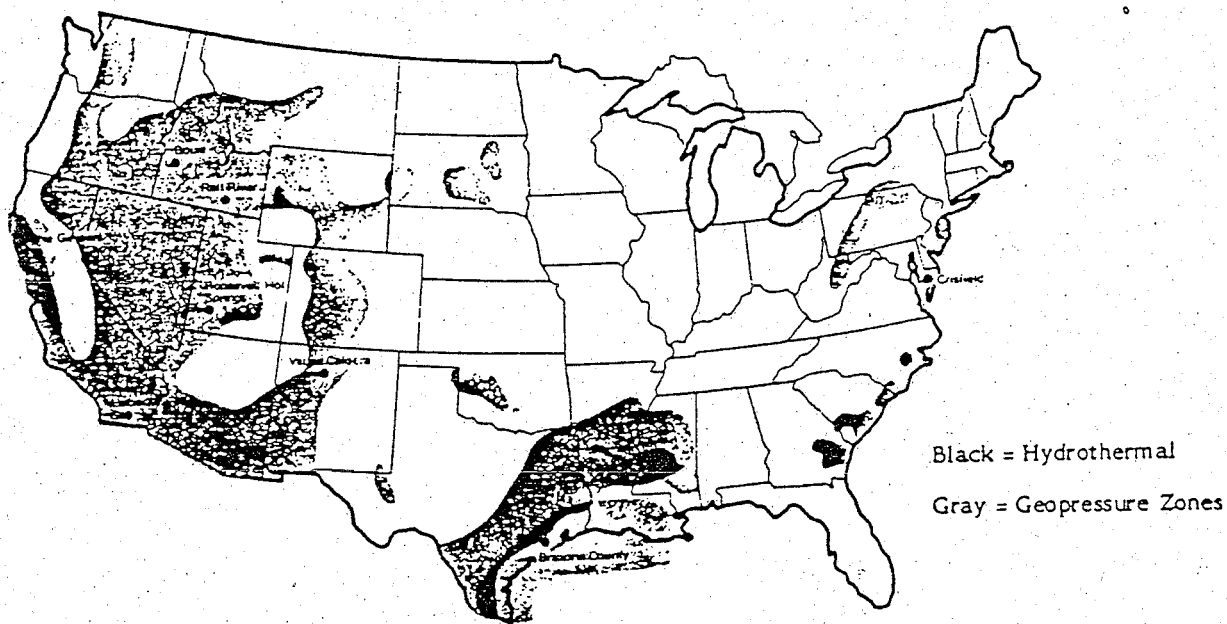
1. The Central Pacific Coast Region is an area of high temperature, moderate-to-high salinity, liquid-dominated hydrothermal resources.

2. The Gulf Coast Region is an area of geopressed, moderate temperature, low-to-moderate salinity hydrothermal resources containing large amounts of dissolved methane.
3. The Northwestern Region is an area of moderate temperature, low-to-moderate salinity, liquid-dominated hydrothermal resources.
4. The Southwestern Region is an area of high-temperature, low-to-moderate salinity, liquid-dominated hydrothermal resources and moderate-temperature resources.
5. The Midwestern and Eastern Region is an area of low-to-moderate temperature, low-salinity hydrothermal resources, in localized areas of shallow igneous intrusives heated in part by traces of naturally radioactive elements.

Figure 3.12-1 indicates Known Geothermal Resources Areas (KGRA's) for the continental U.S. Note too, the variety of proposed and on-line projects which range from electricity generation to commercial district heat applications.

Figure 3.12-1233

REPRESENTATIVE U.S. GEOTHERMAL PROJECTS



<u>Location</u>	<u>Purpose</u>	<u>Technology</u>	<u>Capacity (MW)</u>	<u>Starting Date</u>	<u>Sponsors</u>
The Geysers, California	Electricity, commercial	Natural steam cycle	800	1960-1980	Pacific Gas and Electric Co.; Union Oil Co. of California
Heber, California	Electricity, demonstration	Binary cycle	25	1984	DOE; EPR; San Diego Gas & Electric Co.; Chevron Resources Co.
East Mesa, California	Electricity, pilot	Binary cycle	11	1974	Magma Power Co.
Raft River, Idaho	Electricity, experiment	Binary cycle	5	1980	DOE
Valles Caldera, New Mexico	Electricity, demonstration	Direct-flash steam cycle	50	1982	DOE; Public Service Co. or New Mexico; Union Oil Co. of California
Northern Nevada (site to be selected)	Electricity, commercial	Direct-flash steam cycle	50	1984	Sierra Pacific Power Co. and other utilities.
Heber, California	Electricity, commercial	Direct-flash steam cycle	41	1982	Southern California Edison Co.; Chevron Resources Co.
Roosevelt Hot Springs, Utah	Electricity, commercial	Direct-flash steam cycle	20	(pending)	Utah Power & Light Co.; Phillips Petroleum Co.
Brawley, California	Electricity, pilot	Direct-flash steam cycle	10	1980	Southern California Edison Co.; Union Oil Co. of California
Boise, Idaho	District heat, commercial	NA	NA	1981	DOE; State of Idaho; City of Boise
Cristfield, Maryland	Hydrothermal exploration	NA	NA	1979 (reached 60°C water)	DOE
Brazoria County, Texas	Geopressure, exploration	NA	NA	1979 (well complete)	DOE

The different types of geothermal resources have necessitated three different types of generating technology: the dry-steam process, the flashsteam process, and the binary process. The only dry-steam reservoir now in production in the United States is at The Geysers in Northern California. Dry steam from deep wells is brought directly to electrical generating turbines at about 100 psi pressure. Cool water from previously condensed steam condenses the steam from the turbine exhaust in cooling towers. The several plants at The Geysers, ranging in size up to 135 MW, have been operated since 1960 by Pacific Gas and Electric Company, a California utility. There are now 660 MW of capacity on-line at The Geysers, with 1,400 additional MW expected by 1987.<sup>234</sup>

The main problem associated with dry-steam geothermal generation is hydrogen sulfide ( $H_2S$ ) emissions. The steam at The Geysers contains  $H_2S$  at varying levels; average concentration is around 200 parts per million.<sup>235</sup> Emissions there often exceed California air quality standards.<sup>236</sup> The condenser and the cooling tower are the main points at which  $H_2S$  is released. A supplemental catalyst process and the Stretford process, a widely used industrial pollutant control technology, are now being tested for removing  $H_2S$  from the noncondensable gases.

The dry steam process using surface condensers and the dry steam cycle processes are provided schematically in Figures 3.12-2 and 3.12-3 respectively. Note that the various emission points for hydrogen sulfide are illustrated in Figure 3.12-3.

Figure 3.12-2<sup>237</sup>

DRY STEAM PROCESS USING SURFACE CONDENSERS

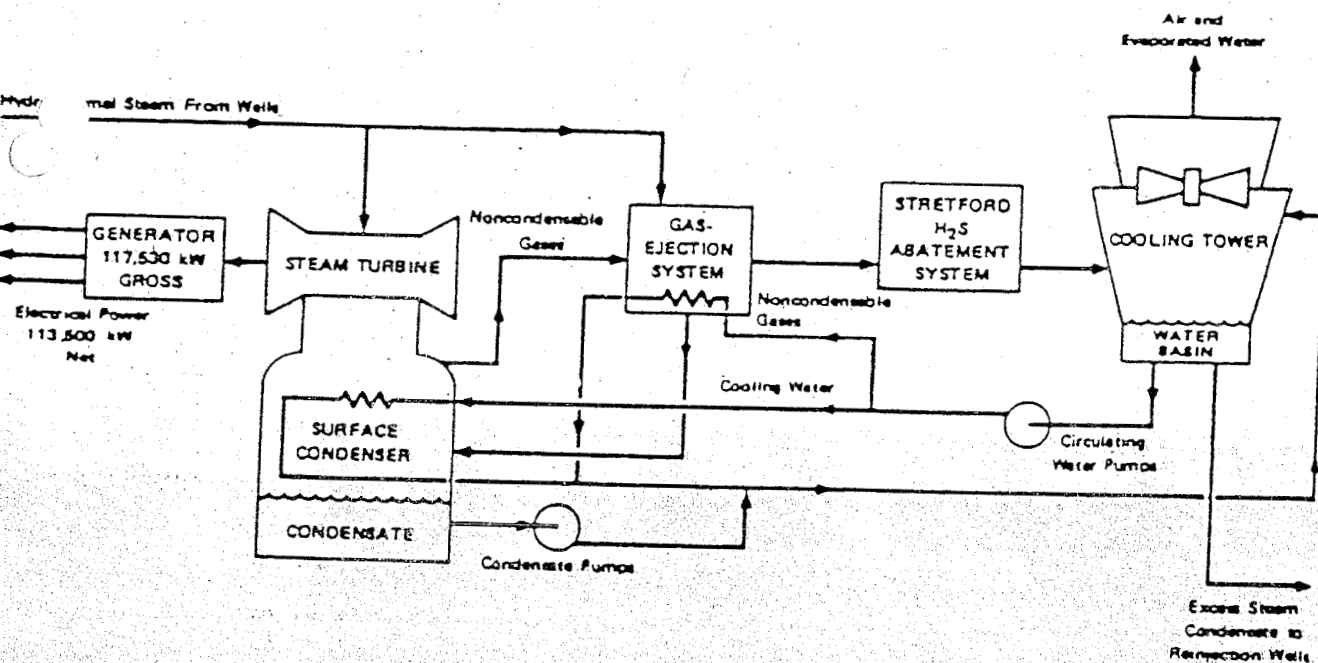
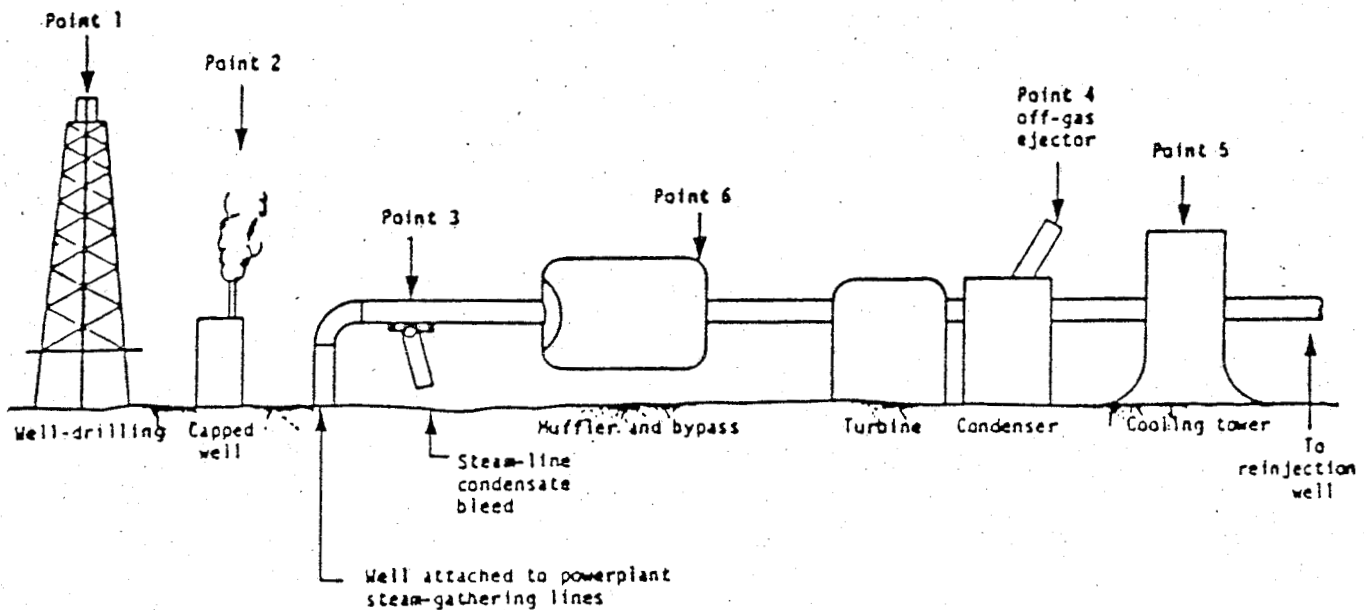


Figure 3.12-3<sup>238</sup>

GEOHERMAL DRY STEAM CYCLE AND EMISSIONS POINTS



The flash-steam process is used for liquid-dominated geothermal reservoirs. None are currently in production, but two plants are planned. One plant is in California's Imperial Valley, and one is in New Mexico.

Liquid-dominated geothermal conversion begins by bringing hot brine to the surface by means of wells. Depending on the depth of its origin, the brine may be at pressures of hundreds of pounds per square inch. The flash process vaporizes (flashes) some of the brine's water to steam and directs it through a conventional steam turbine.

Chevron Resources Company and Southern California Edison Company have contracted to build a 50 MW double-flash plant near Heber, California. The plant will provide electricity for about 45,000 people, and is scheduled for completion in 1982.

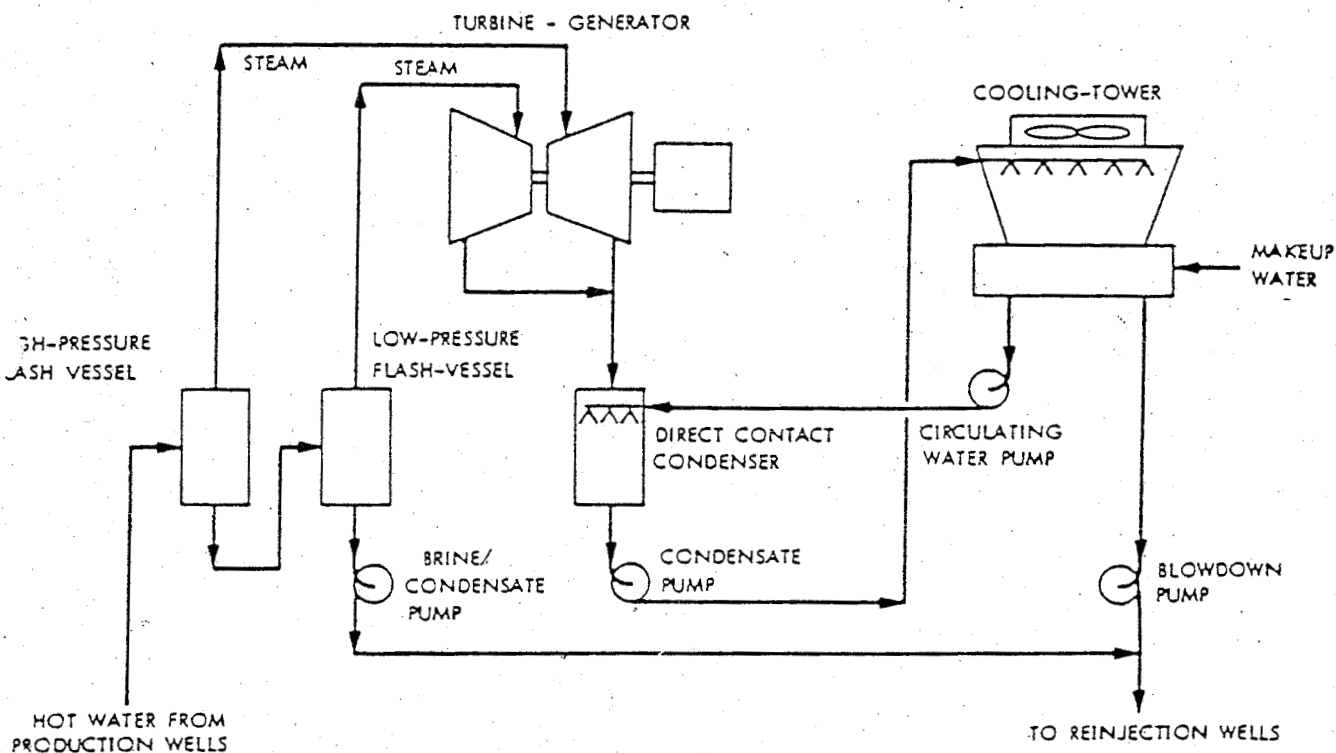
Figure 3.12-4 illustrates a two-stage (high pressure and low pressure) flash-steam electricity generation process. One associated problem with this process is the salinity content of the brine brought to the surface from the wells. The Heber Plant at the Imperial Valley KGRA has been slow to come on-line due to environmental regulations and technological resolution of the salt residue problem.

The binary process, like the flash-steam process, is applicable to liquid-dominated reservoirs. In this process, the brine from the wells passes through a heat exchanger to transfer heat to a working fluid, such as isobutane. The working fluid operates in a closed-loop cycle. The fluid vaporizes in the heat exchangers then expands through the turbines and returns to the heat exchanger after being condensed. The brine, after passing through the heat exchanger, is reinjected into the ground.



Figure 3.12-4<sup>239</sup>

TWO STAGE, FLASHED STEAM POWER GENERATION PROCESS



The binary process is less developed than the flash-steam process. For example, the large turbines that will be used in conjunction with the hydrocarbon working fluid have not been operated in the sizes being considered for use in commercial binary plants.

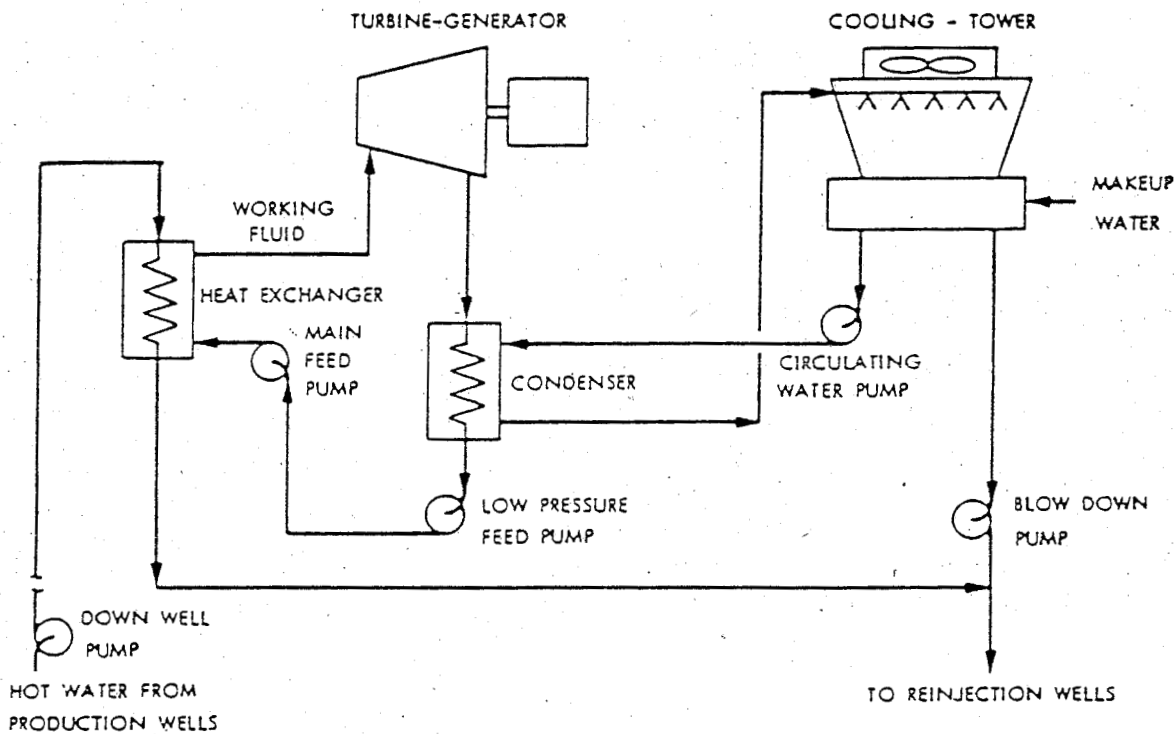
An advantage of the binary process is that it releases no  $H_2S$ . Figure 3.12-5 illustrates the binary process for converting geothermal energy to electricity.

A U.S. government task force has concluded that with an expanded federal program, the U.S. could develop 20-30,000 MW of geothermally generated electrical power by 1985, and as much as 100,000 by 1990.<sup>241</sup> An early federal effort to expand geothermal production was the Geothermal Leasing Act of 1970. The U.S. Department of Energy is involved in many geothermal research programs and demonstrations, including project grants and a loan guarantee program.



Figure 3.12-5<sup>240</sup>

BINARY POWER GENERATION PROCESS



Recently the Department of Energy granted funds to the California Department of Water Resources to study the feasibility of a geothermal-wood waste cogeneration plant near Susanville, California.<sup>242</sup> The DOE is testing wellhead generators in Hawaii.<sup>243</sup> In addition, DOE funds general research in resource exploration and assessment, drilling and utilization technology, and environmental control. It now costs about three times as much to drill a geothermal well as it does a petroleum well. The technology is the same as that for oil wells, but much higher temperatures and harder rock surround geothermal deposits. An impediment to geothermal development is the difficulty in assessing resources. According to DOE, "Early statistics indicate that only one of every ten to fifteen sites identified as prospects may ultimately be confirmed as an economic reservoir."<sup>244</sup>

Environmental impacts which must be addressed for successful geothermal development include subsidence of reservoirs after brine is pumped out, H<sub>2</sub>S emissions, disposal of spent brine, seismicity induced by drilling and general geologic disruption, groundwater contamination, and water requirements for cooling. Reinjection of spent brine into the reservoir seems to mitigate several of these problems.

Despite the problems, geothermal electrical generation is a cost-effective technology. Levelized 1980 generation costs for steam geothermal are estimated to be about 5.6 cents per kilowatt hour, compared to about 7.0 cents per kilowatt hour for coal-fired plants.<sup>245</sup>

In addition to the "indirect" applications of geothermal energy (conversion to electricity via steam turbines), there are a variety of direct uses. Direct utilization of geothermal energy for space and process heating, for the most part, uses known technology. The utilization of geothermal energy requires only conventional engineering techniques rather than revolutionary advances or major scientific discoveries. The technology, reliability, economics and environmental acceptability have been demonstrated throughout the world.

Each geothermal resource has unique physical characteristics and conversion systems must be designed accordingly. There can be some problems with corrosion and scaling (generally confined to higher temperature resources), but most of these problems can be surmounted by proper materials selection and engineering designs. For some resources, standard materials can be used if particular attention is given to the removal of atmospheric and geothermally-generated gases. For others, system designs are possible which limit geothermal water to a small portion of the overall system by utilizing highly efficient heat exchangers and corrosion resistant materials in the primary side of the system.

Today, the equivalent of over 7,000 megawatts thermal (MWt) of geothermal resources are utilized worldwide for space heating and cooling (space conditioning), agriculture and aquaculture production and for industrial processes.<sup>246</sup> Table 3.12-1 indicates the variety of potential direct heat end-uses and the required temperatures for each application.

Generally, the agriculturally-related applications utilize the lowest temperatures, with typical values from 80°-180°F (27°-82°C). The amount and types of chemicals and dissolved gases in the resource such as boron, arsenic and hydrogen sulfide, can be a major problem. However, use of heat exchangers and proper venting of gases can solve this problem. Almost all of the agriculturally-related energy utilization is in the Soviet Union where over 5,000 MWt are reportedly being used.

Space heating generally utilizes temperatures in the range of 150°-212°F (66°-100°C), with 100°F (38°C) being used in some cases. Use of groundwater heat pumps can extend this range down to 55°F (13°C). The leading user of geothermal energy for space heating is Iceland, where over 50 percent of the country is provided with geothermal heat. The only geothermal cooling application currently on-line is Rotorua, New Zealand, at the International Hotel. However, many other cooling and refrigeration applications are presently being considered.<sup>248</sup>

Industrial process heat typically requires the highest temperatures, using both steam and super-heated water. Temperatures up to 300°F (150°C) are normally required. However, lower temperatures can be used in some cases, especially for drying of various agricultural products. Though there are relatively few examples of industrial processing using geothermal energy, they represent a wide range of applications from drying of wool, fish, earth, and lumber, to pulp and paper processing and chemical extraction. The two largest industrial uses are the diatomaceous earth drying plant in Iceland and the paper and wood processing plant in New Zealand. Table 3.12-2 indicates the extent of worldwide use of geothermal energy in direct-heat applications.

Table 3.12-1<sup>247</sup>

TEMPERATURES REQUIRED FOR COMMERCIAL, INDUSTRIAL,  
AND AGRICULTURAL PROCESS HEAT FROM GEOTHERMAL SOURCES

DEGREES CENTRIGRADE

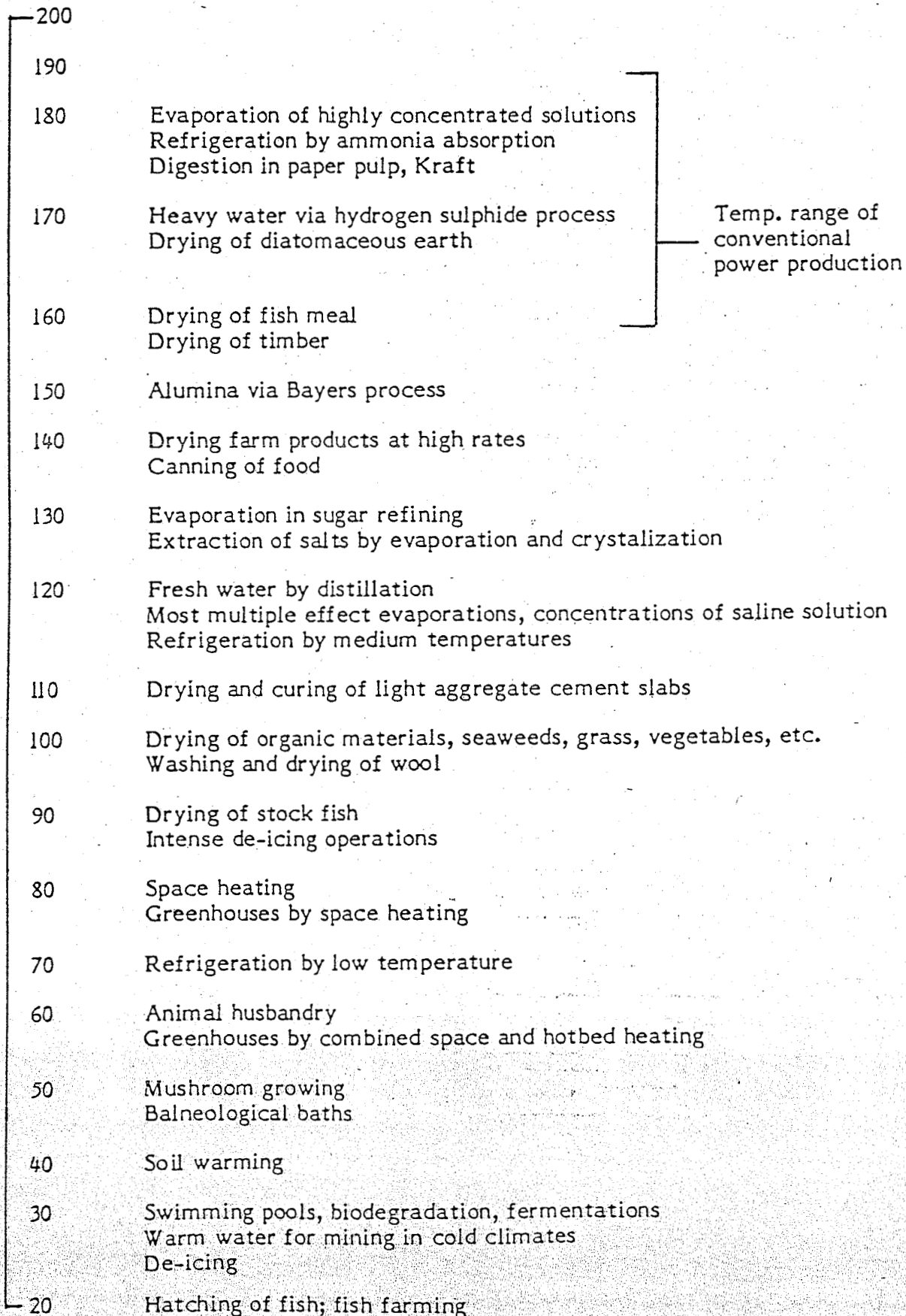


Table 3.12-2<sup>249</sup>

WORLDWIDE DIRECT USE OF GEOTHERMAL ENERGY

<u>Country</u>	<u>Space Heating/ Cooling (MWt)</u>	<u>Agriculture/ Aquaculture (MWt)</u>	<u>Industrial Processes (MWt)</u>
Iceland	680	40	50
New Zealand	50	10	150
Japan	10	30	5
U.S.S.R.	120	5,100	—
Hungary	300	370	—
Italy	50	5	20
France	10	—	—
Others	10	10	5
USA	<u>75</u>	<u>5</u>	<u>5</u>
TOTAL	1,245	5,570	235

Benefits of Direct Application

The main advantages of direct utilization of geothermal energy are:

- High conversion efficiency (80-90 percent).
- The use of low-temperature resources, which are numerous and readily available.
- The use of many off-the-shelf hardware items (pumps, controls, pipe, etc.).
- Short development time as compared to electrical energy development.
- Lower-temperature resources require less expensive well development (the wells are shallower in some cases), can be drilled with conventional drilling equipment, and the water can technically be transported 20-40 miles (32-64 km) without major heat losses.<sup>250</sup>

At current fuel prices, geothermal energy for direct-heat applications should cost about the same or less than the corresponding fossil fuel applications. Due to the expected escalation of fossil fuel prices, the relative costs of geothermal systems should decline. Most geothermal direct-use systems should pay for themselves in five to ten years due to savings over conventional fuel use applications.<sup>251</sup>

Reservoir characteristics dominate geothermal energy costs because they determine the cost of the equipment required to produce and reinject the geothermal fluid used, and this equipment is by far the most costly factor in a geothermal system.<sup>252</sup>

The degree to which available geothermal energy is utilized by a commercial, industrial, or agricultural process is the most important element in determining the cost of energy in that process. Under conditions of high energy utilization, geothermal energy is at present competitive with fossil energy, and this competitive position is likely to improve.<sup>253</sup>



## Wind Energy (3.13)-

### Introduction (3.13-1)

Wind power is a renewable energy technology with the potential to contribute substantially in the near term to reducing our dependence on nonrenewable energy resources. Thousands of years ago in Persia windmills were used to grind grain. Hundreds of years ago in Europe windmills were used to pump water. In recent times windmills were used on American farms to pump water and to produce small amounts of electricity. Today new designs involving the latest advances in materials, aerodynamics, electronics, structural engineering, and control theory are being developed both by government funded programs and by the private sector.

Wind energy systems are currently under development in the United States and in a number of other countries including Sweden, West Germany, Denmark, the Netherlands, Great Britain, Japan, and the Peoples' Republic of China. Through this diversity of development, many new concepts and designs are evolving.

### System Description (3.13-2)

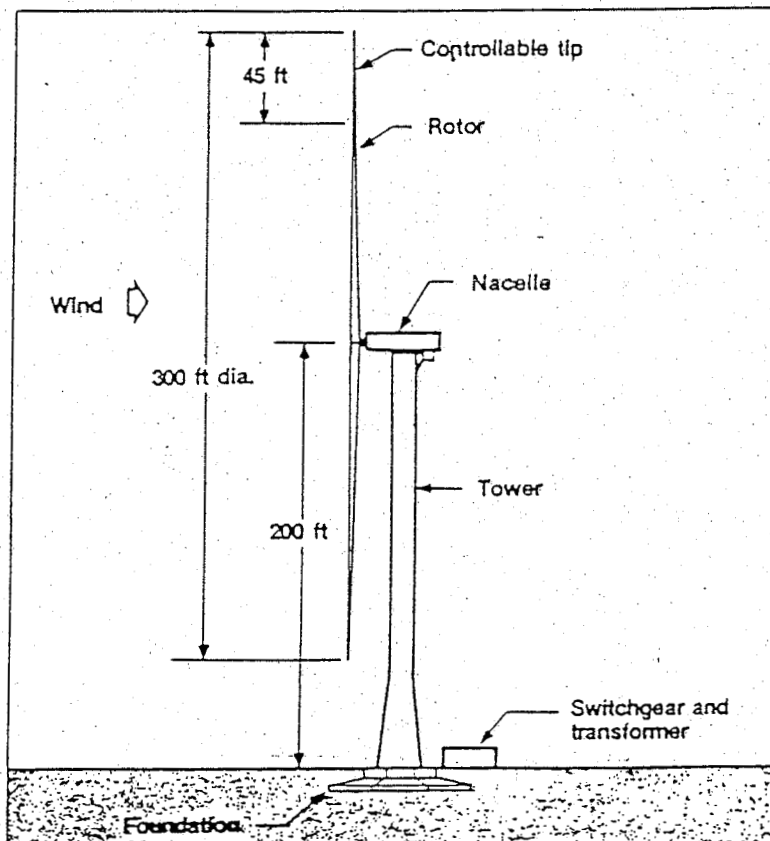
Modern windmills are more appropriately described as wind energy conversion systems or "WECS." Those WECS which convert wind energy to electricity are called wind turbine generators, since the wind is actually powering a turbine consisting of a set of rotating propellers or blades which in turn are connected to an electrical generator by means of a shaft. As Figure 3.13-1 illustrates, the basic components of a wind turbine generator are relatively simple. The blades which collect the wind's energy are usually connected to the electrical generator via a set of gears or speed increasers which convert the speed of the shaft rotating at 30 to 120 rpm to 1,800 rpm on the generator side of the gear box. The wind system depicted here is the 2.5 MW MOD-2 horizontal axis system developed by Boeing for DOE and NASA in which a two or three bladed propeller rotates on an axis which is horizontal to the wind direction. The rotor is mounted on top of a tall tower to take advantage of the fact that wind speed generally increases with height above ground.

The horizontal axis wind system depicted in Figure 3.13-1 is the most thoroughly developed system currently being used to produce electricity, although vertical axis systems are also being developed and tested. The most successful vertical axis design developed to date is the Darrieus concept, in which two or three slender blades resembling airfoils are attached to the top and bottom of a vertical shaft or torque tube. This unit is one of a family of designs currently being developed by Alcoa. Although less efficient than a horizontal-axis WECS of similar sweep area, vertical axis machines have the advantage of accepting winds from any direction without the need for the rotor turning or yawing to face the wind. Another advantage of vertical axis machines is the ability to locate all the machinery and controls at or near ground level, thus providing much easier access for maintenance, as well as reducing the load carrying requirements of the tower.



Figure 3.13-1 254

MOD-2 WIND TURBINE CONFIGURATION  
DIAMETER: 91m, RATED POWER: 2.5 MW

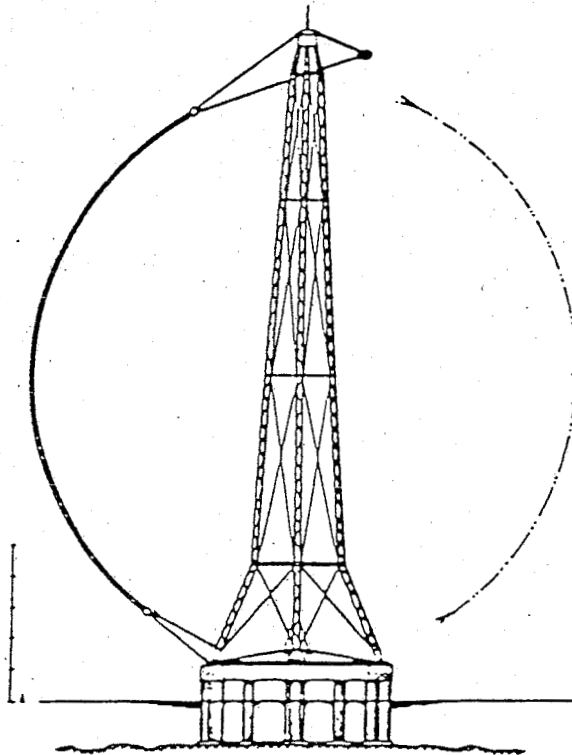


The Alcoa vertical axis systems range in size from eight kilowatts to 500 kilowatts. The Canadian National Research Council and DAF-Indal have developed and tested 50 and 224 kilowatt vertical axis systems. Perhaps the most ambitious vertical axis design still in the conceptual design stage is the twenty megawatt "Poseidon L-180" vertical axis system proposed by Olle Ljungstrom of the Swedish Aeronautical Research Institute. The Poseidon system dimensions are 180 meter rotor diameter by 210 meter tower height. Ljungstrom's proposed design is shown in Figure 3.13-2.

Wind systems can be classified according to physical scale or power rating at a reference windspeed. Systems rated at less than 100 kilowatts at twenty miles per hour (32.2 kilometers per hour) wind speed are classified by the DOE as "small-scale," while systems larger than 100 kilowatts are classified as "large-scale." Actually there is a "medium-scale" that overlaps these two scales, and the distinction is rather imprecise. For the purpose of discussion we can arbitrarily select 50-100 kilowatts as the lower end of "medium-scale," while 500-1,000 kilowatts might be the upper end of the "medium-scale" range.

Figure 3.13-2 255

"POSEIDON L-180" TYPE DESIGN  
DIAMETER: 180m, RATED POWER: 20 MW

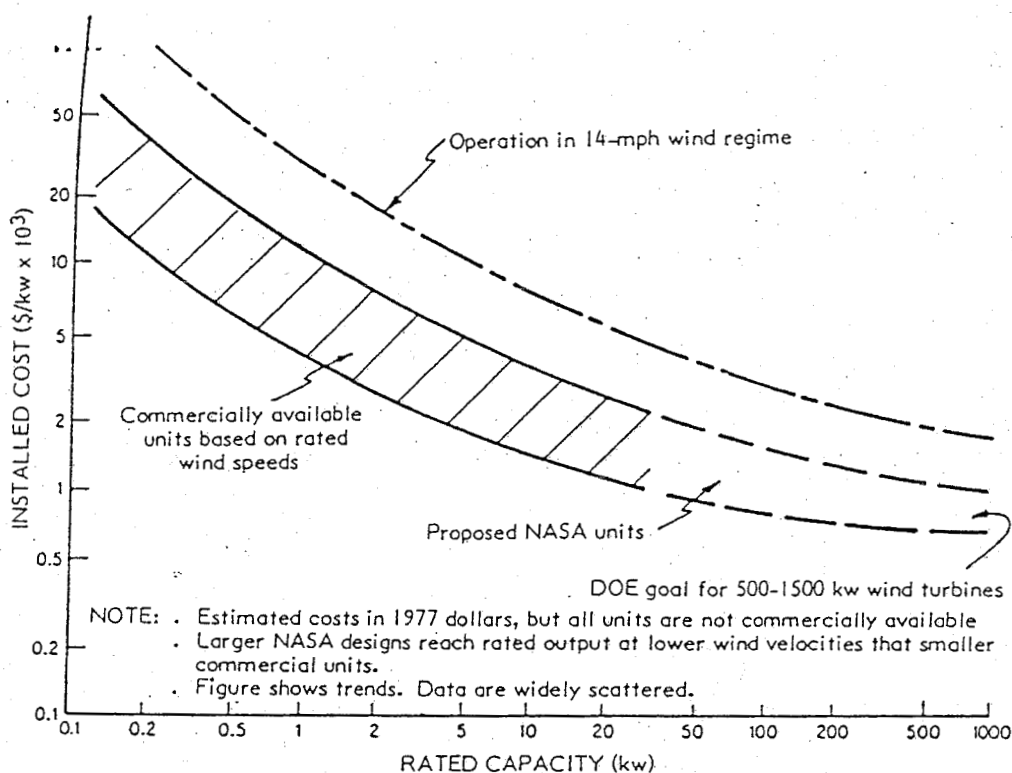


### Large-Scale Systems

Large-scale wind turbine systems in the megawatt class sited in clusters of 25 or more units (wind farms) appear to offer the greatest promise for producing large quantities of electricity at the lowest cost. Total system costs per installed kilowatt of capacity tend to decrease with increasing capacity up to a certain point. Above a certain capacity the weight and cost of the rotor increase faster than the power output increases, with the result that very large-scale machines appear to undergo diminishing economies of scale. Generally speaking, the optimum cost machines appear to be in the range of one to five megawatts. Figure 3.13-3 illustrates the trend of anticipated cost decrease with increasing size. This should be interpreted as a general anticipated trend rather than observed fact. As more experience is gained in the development and testing of machines in various sizes, the costs will be clarified. Structural optimization, particularly for blades, tower, and gears will be useful in reducing the costs of the large machines. As indicated previously, the availability of higher windspeeds at greater heights above the ground permit more energy capture per unit rotor area. This tends to reduce the cost of electricity for the larger machines by providing greater energy capture per unit swept rotor area.

Figure 3.13-3 256

COST OF WIND GENERATORS



Large-scale wind systems are being developed in this country by the federal government wind program under the management of the Department of Energy (DOE) and the NASA Lewis Research Center. The DOE/NASA program goal is to develop reliable and economical systems which ultimately can be commercialized. The first generation machines developed by NASA and its contractors were primarily research tools from which engineering and operational experience could be gained. Machines of various sizes operating under different loads, environments, and in different utility grids were tested.

The basic first generation NASA design was the MOD-O series. This unit is the DC-3 "workhorse" model from which valuable operational and maintenance data are being obtained. The MOD-OA system has an aluminum rotor of 125 foot diameter mounted on a 100 foot (30.5 meter) tower and produces 200 kw at 21.7 miles per hour (31.9 kilometers per hour).

The unit at Clayton, New Mexico, installed at the end of 1977 logged more than 5,000 hours of operation during its first two years, and the basic system design has been verified.<sup>257</sup>

Another first generation machine, the MOD-1, is basically a scaled-up version of the MOD-0 series. This system is designed to produce two megawatts of power at a rated wind speed of 32.6 miles per hour (52.5 kilometers per hour) measured at 140 foot (42.7 meter) hub height. The rotor is made from welded steel and has a diameter of 200 feet (61 meters). This machine was developed by the General Electric Company and was dedicated in July 1979. The unit is located atop Howard's Knob at Boone, North Carolina. According to recent results reported by NASA the unit's measured performance data is very close to the anticipated design output.<sup>258</sup>

A second generation design being developed for NASA by Boeing, is the MOD-2 which is designed to produce 2.5 megawatts at 27.7 miles per hour (44.6 kilometers per hour) measured at 200 foot (61 meter) hub height. The welded steel rotor is 300 feet (91.4 meters) in diameter. This system has been developed specifically for the electric utility market with a 100th unit cost goal of four cents per kilowatt hour (1977 dollars) when located at a site with moderate wind speed (fourteen miles per hour or 22.5 kilometers per hour average measured at 30 feet or 9.1 meters). A cluster of three MOD-2 units will be constructed at Goodnoe Hills near Goldendale, Washington. Start-up of the first machine is planned for December 1980.

Advanced systems planned for development under NASA sponsorship are the MOD-5 and MOD-6 systems. MOD-5 will be an advanced multimegawatt scale design under parallel development contracts to Boeing and General Electric. MOD-6 will be a second generation design in the 100 kilowatt class with parallel contracts for horizontal axis and vertical axis designs. Start-up of both of these prototype systems will not begin until the end of 1983.

In addition to these government-funded development programs, a number of privately-funded large wind turbine programs are being developed. The Hamilton-Standard Division of United Technologies Corporation is working under a joint arrangement with a Swedish shipbuilding concern to develop a three megawatt, 255 foot (77.7 meter) diameter horizontal axis system for the Swedish National Board for Energy Resource Development. The WTS-3 design incorporates many advanced concepts including the use of a teetered rotor to reduce loads, a "soft" tower to provide acceptable structural resonance characteristics at minimum cost, fiberglass blades for improved fatigue life, and the use of "free" or uncontrolled yaw, which eliminates the need for power to drive the rotor to face the wind.

The prototype WTS-3 unit will begin testing in Sweden in late 1981. An uprated, four megawatt system verification unit, the WTS-4 has been ordered by the U.S. Department of the Interior for tests at Medicine Bow, Wyoming starting in late 1981. If successful, quantities of large-scale units will be ordered by the Interior Department for wind farm operation.

Another large system being developed privately is the three megawatt Bendix/Wind Power Products system which features a three-bladed, 165 foot (50.3 meter) diameter rotor that will develop its rated power at 40 miles per hour (64.4 kilometers per hour). A prototype unit has been ordered for testing by the Southern California Edison Company starting in late 1980. The unit is sited in the San Geronio Pass near Palm Springs, California. The machine is estimated to produce about six million kilowatt hours per year and would save about 10,000 barrels of oil annually.

## Small-Scale Systems

Small-scale systems are being developed, tested, and sold by a developing industry which currently numbers about 40 companies. The federal government is funding the development and testing of small-scale prototype systems in the range of 1-40 kilowatts, as well as testing commercially available systems developed by the industry. These systems would be used in a variety of applications for farm, residential, and rural applications. The DOE operates a national test center at Rocky Flats, Colorado for small wind energy conversion systems (SWECS) under contract to Rockwell International.

The SWECS under development by the DOE are summarized in Table 3.13-1. The one to two kilowatt high-reliability systems are for remote locations where conventional power costs are high. The four to eight kilowatt systems are for home or farm use. The fifteen to eighteen kilowatt systems are for small community, industry, or farm applications. The 40 kilowatt systems are for deep well irrigation, farm/ranch application, and for small isolated communities or industries. Some of these systems are shown in Figure 3.13-4.

Table 3.13-1 259

### SPECIFICATIONS OF SWECS UNDER DEVELOPMENT BY DOE/ROCKY FLATS

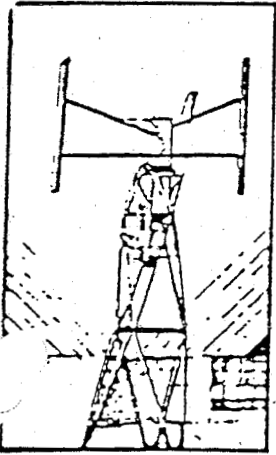
<u>Contractor</u>	<u>Rated Power, kw @ 20 mph.</u>	<u>Rotor Size*, feet</u>
<u>1-2 kw (High Reliability) Systems</u>		
Enertech	2.3	16.4
Northwind	2.0	16.4
Aerospace Systems, Inc. (VA)	1.0	15 x 8
<u>4-6 kw Systems</u>		
Northwind	4.0	32.8
Structural Composit 5.7		31.2
Tumac (VA)	6.2	21 x 32
<u>8 kw Systems</u>		
Windworks	8.0	31
United Technologies Research Center	9.0	31
Grumman	11.0	33.25
<u>15-18 kw Systems</u>		
Enertech	15.0	44
United Technologies Research Center	18.0	47.9
<u>40 kw Systems</u>		
Kaman Aerospace	40	64
McDonnell Douglas	40	32.5 x 65

\*For Vertical axis systems (VA) first figure is rotor diameter, second figure is rotor height.

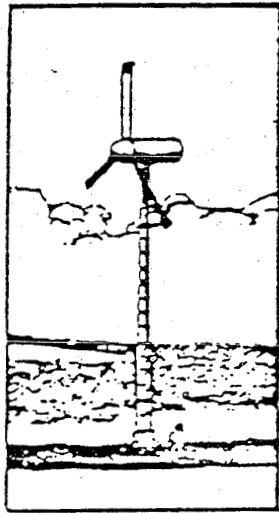


Figure 3.13-4 260

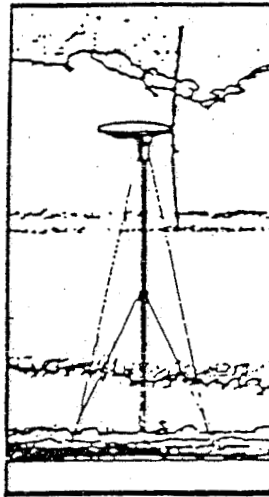
ADVANCED SWECS UNDER DEVELOPMENT  
(1-2 kw and 8 kw)



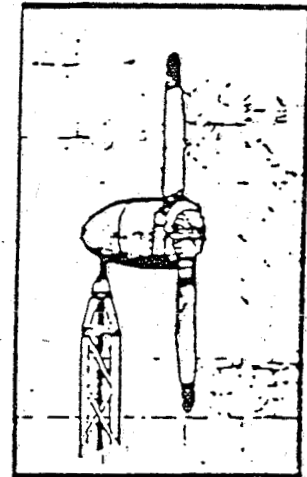
Aerospace Systems, Inc.  
1 kw - High Reliability



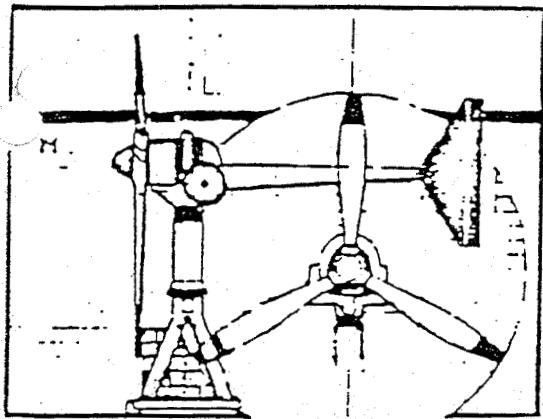
Grumman  
8 kw



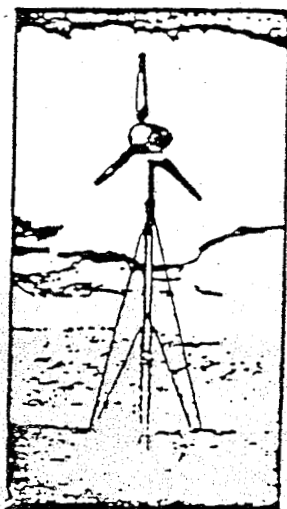
United Technologies  
Research Center  
8 kw



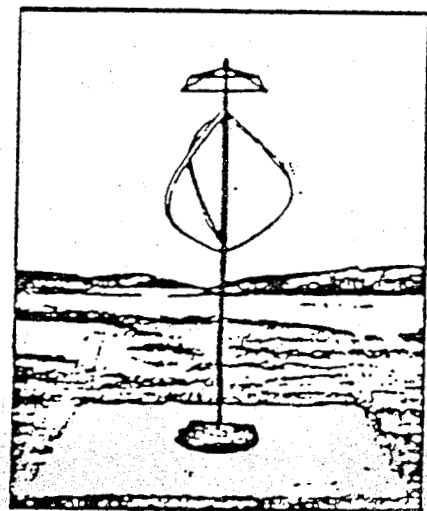
Enertech  
1 kw - High Reliability



North Wind  
1 kw - High Reliability



Windworks  
8 kw



Alcoa  
8 kw



A number of privately developed, commercially available machines are currently being evaluated at Rocky Flats. These systems include the one kilowatt systems manufactured by Sencenbaugh and Aeropower, the ten kilowatt Millville unit, the 25 kilowatt Jay Carter Enterprises system, and the 40 kilowatt system of Mehrkam Energy Development Company. The Jay Carter machine, capable of producing 25 kilowatts at 25 miles per hour (40.2 kilometers per hour), is illustrative of what can be accomplished by the private sector. The Carter design, which is highly innovative, incorporates molded fiberglass blades, passive aerodynamic overspeed control, and flexible blades for load reduction during operation in high wind speeds. Currently the unit is selling for \$16,000 with site preparation, delivery, and installation costs dependent of the specifics of the site. Total turnkey installed cost of around \$25,000 are typical for this model.

Since production lines have not yet been established for the DOE-developed machines, actual production costs are not yet available; however, DOE-sponsored field evaluation tests using privately-developed systems are being conducted during 1980 and 1981 to learn more about actual costs and to gain operational experience.

### Wind Energy Potential (3.13-3)

Wind Energy potential involves both the power available in the wind and the efficiency of a WECS to convert this power to useful electrical or mechanical energy. The theoretical maximum efficiency of a horizontal axis wind turbine is 59.3 percent. Practically speaking, a well designed wind turbine should have a overall efficiency around 40 to 45 percent at rated wind speed and lower for other wind speeds below or above the rated wind speed.

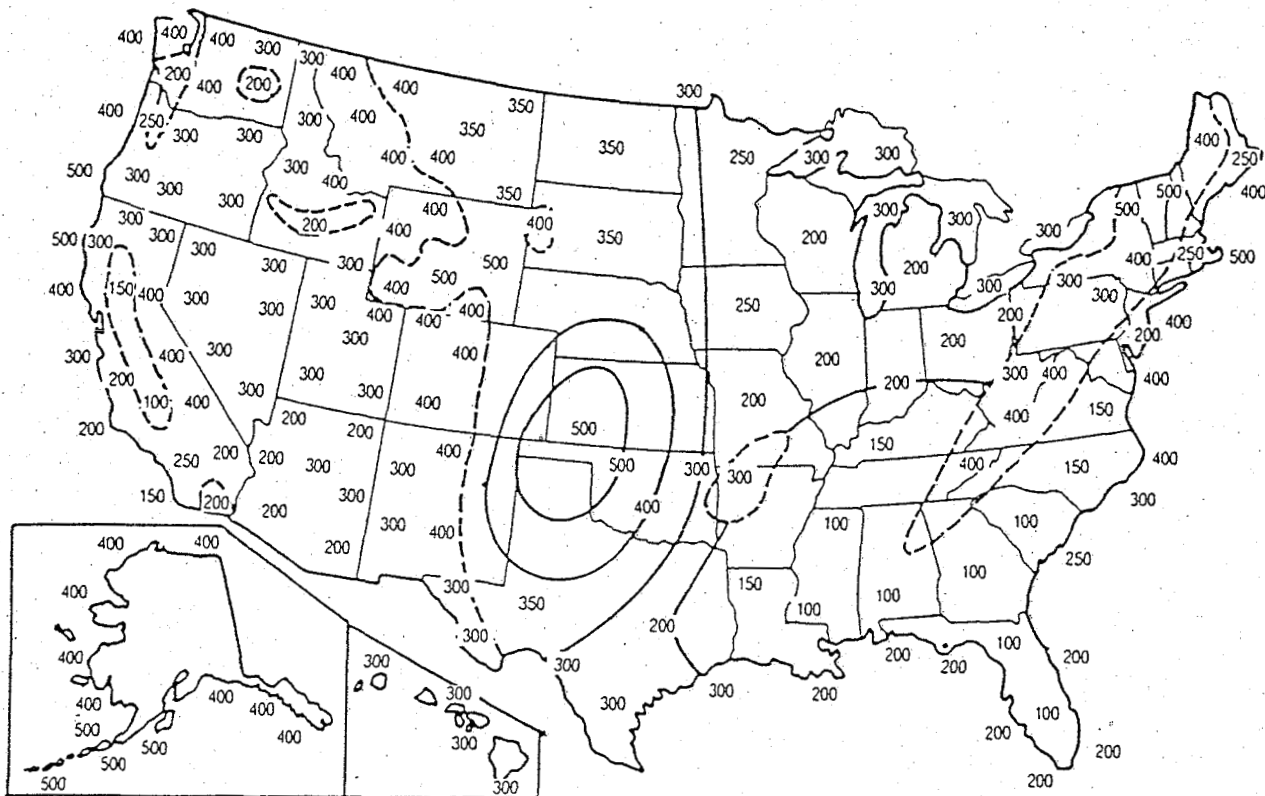
Since the power output is so sensitive to the wind speed, and since the average wind speed at a site is generally considerably less than the rated wind speed, the average power produced by a turbine will always be less than the rated output. For example, for a turbine rated at 32 miles per hour (51.5 kilometers per hour) wind speed, the power at sixteen miles per hour (25.7 kilometers per hour) will be one eighth of the rated output. The average power produced by a wind turbine at a given site is perhaps more indicative of performance. The capacity factor is a measure of the average power of the wind turbine. A unit that runs at 100 percent of its rated power over a year's time has a capacity factor equal to 100 percent. Depending on site location and wind turbine generator characteristics, the capacity factor can vary from 25 percent to as high as 45 percent for a typical moderately windy site, although higher capacity factors are possible for certain very windy sites such as the Hawaiian Islands.

### Resource Base

Estimates of the total wind resource base for the U.S. vary considerably. An assessment of the nation's wind resources has been initiated by the Battelle Pacific Northwest Laboratories under the direction of the DOE. Figure 3.13-5 is an estimate made by Battelle of the annual mean wind power in the U.S. at 50 meters above exposed areas. Vast areas of the U.S. including the Northeast, the Appalachian Mountains, the Great Plains, the western states, and the Pacific Coast states appear to have consistently strong winds.

Figure 3.13-5 261

ANNUAL AVERAGE WIND POWER (WATTS/M<sup>2</sup>) AT 50M

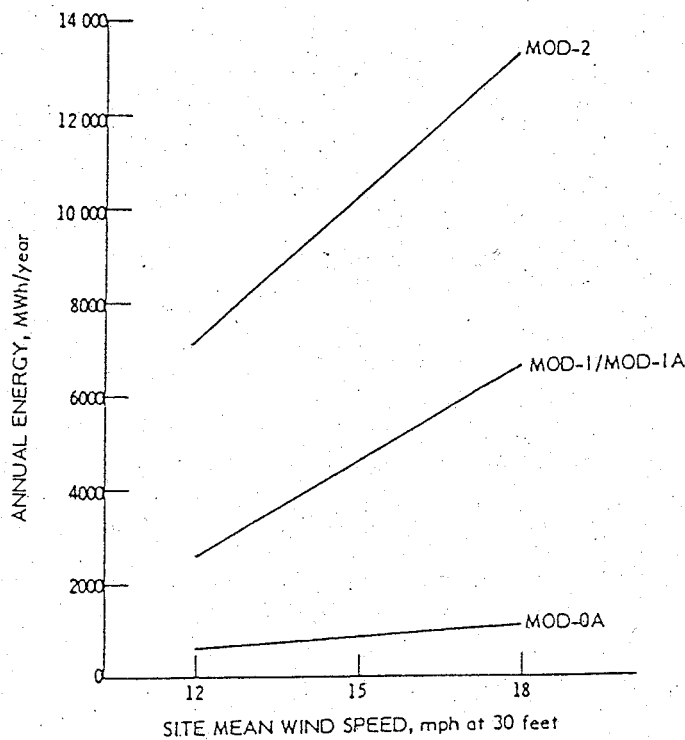


Although average wind speed is an unreliable indicator of the strength of a given site, it is a commonly used indicator. Generally speaking, a site with an annual average wind speed of fourteen miles per hour measured at a 30 foot or ten meter height is considered a "moderately windy" site. Sites with mean wind speed around twelve miles per hour would be marginal, while sites with sixteen miles per hour (25.7 kilometers per hour) or greater mean wind speed would be considered highly energetic. Figure 3.13-6 provides an indication of the annual energy output of the NASA MOD series of wind turbines as a function of site mean wind speed.

Wind characteristics tend to be highly variable from one site to another or from one day to another at a given site. This requires an on-site measurement program of one to two year's duration collecting hourly wind speed and direction data in order to ascertain the viability of a given site. Site winds tend to be highly seasonal with different diurnal (daily) wind patterns from one season to another. A number of states, most notably, California, Hawaii, and Oregon, have initiated wind prospecting programs to systematically search out sites that have the best wind characteristics. Owing to the fact that wind power varies as the cube of the wind speed, a one or two mile per hour difference in mean annual wind speed between sites can have a significant bearing on the economic viability of a given site.

Figure 3.13-6 262.

ANNUAL ENERGY OUTPUT



Energy Production (3.13-4)

The total potential annual energy production for the U.S. from wind turbines is probably in excess of  $2 \times 10^{12}$  kilowatt hours ( $2 \times 10^9$  MW hours) the approximate magnitude of the current annual electricity production for the U.S. This amount of electricity could be produced from approximately 200,000 megawatt-scale wind turbines rated at four megawatts each. These machines would save the equivalent of three million barrels of oil daily, which is greater than the current level of oil imports to the U.S. Assuming the units are spaced at ten diameters apart to avoid aerodynamic interference, the machines would require 67,000 square miles (173,529.2 square kilometers) of involved land, roughly two percent of the land area of the U.S. Approximately ten acres of land would be required for each machine and its associated roads, maintenance facilities and transmission lines; thus, a little more than 3,000 square miles (7,700 square kilometers) of land would be exclusively dedicated to the machines (about five percent of the 67,000 square miles or 173,529.2 square kilometers of "involved" terrain).

It is important to note that either a utility back-up or energy storage system is required with wind systems owing to the difficulty of matching the demand for power with the availability of the wind. If wind machines are deployed and interconnected with a common utility grid over a large geographical area, the diversity of the wind characteristics at the various sites will result in a fraction of the installed capacity which can be earmarked as firm; thus, a capacity "credit" can be attributed to the wind system. For a ten to twenty percent penetration of wind systems perhaps 20 to 30 percent or more of the installed capacity could be

counted as firm. The actual amount of wind capacity that can be integrated with a given utility system and the capacity credit which can be attributed to these systems depends on the particular demand profile of the network, the mix of conventional generation systems, the local, site-specific wind characteristics, and the wind turbine operational characteristics. A utility-specific simulation using hourly wind data is required to analyze the situation in order to estimate the maximum amount of wind energy penetration that can be sustained.

#### Development and Production Issues (3.13-5)

The constraints to wind system deployment are economic rather than strictly technical issues. The development and test programs of the past several years sponsored by the federal government and by private industry have proven the technical viability of the basic design concepts for wind turbines as large as 200 feet (61 meters) in diameter. The key issue is that of cost to generate electricity. This cost is a function of system performance, reliability, and service life. The experience gained to date with the NASA MOD-OA 200 kilowatt prototype wind system which has been operating at Clayton, New Mexico since November 1977, has been very useful in delineating all three of these major potential problem areas. While the predicted power levels have actually been achieved, the annual energy production during the first year was about half of the predicted value.<sup>263</sup>

Improvement in performance is being examined by studies that compare various design choices on the basis of improved energy capture for a given cost. Both the MOD-2 and the WTS-3 were designed after very detailed trade-off studies. Various new design concepts will be employed in the design and development of advanced second generation designs such as the Westinghouse MOD-OW 500 to 900 kw system and the NASA MOD-5 multimegawatt systems to be developed in parallel by Boeing and General Electric. Use of variable speed rotors and advanced high performance airfoils offer the means to increase energy capture.<sup>264,265</sup> NASA is attempting to obtain approximately 25 percent improvement in cost of electricity for the MOD-5 compared to the MOD-2 design.<sup>266</sup> The cost of electricity for the 100th unit would be three cents per kilowatt hour (1977 dollars) or approximately four cents per kilowatt hour (current 1980 dollars). Even if this goal is not achieved, the fact that current fuel oil costs are in excess of five cents per kilowatt hour, and increasing more rapidly than the general rate of inflation, indicates that by the mid-1980s the cost of electricity from mass-produced large wind turbines could be well below the cost of oil-fired electricity.

By mid-1982 both the MOD-2 and WTS-3 megawatt-scale designs will have undergone sufficient test experience to verify the basic designs. Barring any unforeseen problems these units could be in mass production at that time. The smaller 500 kw MOD-OW systems could be in mass production before that date. The small and medium scale units should also have had sufficient test experience by mid-1982 to be considered ready for mass production.

## Resource Issues

There appears to be a very large resource base capable of supplying perhaps as much as  $2 \times 10^{12}$  kwh per year. This would be equal to 6.82 Quads of primary energy displacement or about twenty percent of the total U.S. energy requirement projected for the 1990s. Achievement of a target of ten to twenty percent of the U.S. electricity production, an equivalent of 50,00 to 100,000 megawatts of installed wind system capacity and two to four Quads of primary energy displacement, would require the location and verification of 5,000 to 10,000 square miles (25,899.9 square kilometers) of sites swept by winds of fourteen miles per hour or greater mean annual wind speed. A massive site prospecting and verification program will be required to locate and verify this many sites. Owing to the fact that many sites will not prove viable due to poor quality resource or siting difficulties, perhaps 50 times as many sites will have to be surveyed as are ultimately developed. The cost to survey and validate 100,000 megawatts of wind resource would be between one and three billion dollars. This is based on an estimate made by Ginosar<sup>267</sup> of the cost to develop sites for approximately 100 large wind farms in California totaling 10,000 megawatts of installed capacity and an estimate by Lindley and Melton<sup>268</sup> of the costs to validate a 450 MW wind farm for Hawaii.

There are some unresolved questions concerning how much wind measurement is ultimately required to validate a site prior to erecting a large number of wind turbines. A case in point is an 80 megawatt wind farm project planned for the Hawaiian Electric Company under the direction of Windfarms, Ltd., a California-based wind farm developed. Although a number of site surveys and measurements have already been performed over the past five years on the island of Oahu, and a great deal of useful wind data have been collected, more detailed site-specific measurements costing about \$600,000 will be required prior to siting approximately 20 to 32 large turbines. Tall meteorological towers for collecting one minute averages of wind speed at several heights will be installed in order to accurately predict the turbines' performance. Similar measurement programs are already underway in California at candidate wind farm sites under the sponsorship of the California Energy Commission and the two largest investor-owned utility companies, Southern California Edison and Pacific Gas and Electric Company. These pioneering resource validation programs and subsequent wind turbine tests at the Hawaii and California sites will resolve most of the technical uncertainties.

Fortunately, in the case of large wind farms, the cost of wind resource validation is only about one percent of the total cost of installing a wind farm. The importance of this activity is overriding owing to the sensitivity of the economics to site resource magnitude. A one mile per hour (1.6 kilometers per hour) decrease of site mean annual wind speed from the nominal design of fourteen miles per hour will result in a fifteen percent increase in the cost of electricity for the MOD-2.

For single-unit installation of small wind systems the need for accurate site resource data is perhaps even more critical for economic success since a few miles per hour difference in mean annual wind speed can spell the

difference between a marginally economic installation and an uneconomic one. The reasons for this are primarily that the SWECS unit installed cost per rated kw tend to be higher than for the medium scale or large scale systems, thus site wind energy availability is even more important for success. Compounding this is the fact that a SWECS unit will probably be installed at the user's site, rather than at some remote, more energetic site. The user then, must have accurate information on his site wind resource. Data from nearby measurement stations are generally not indicative of the local site wind resource; thus onsite wind measurements are required. The cost of performing these measurements is going to be a much greater fraction of the total cost than for the larger machines. The site analysis work for example might cost on the order of ten to fifteen percent of the total cost of installing a small wind system. For example, for siting an eight kw system costing \$15,000 installed, a one year meteorological onsite measurement program might cost on the order of \$1,500 for equipment leasing, data collection, data analysis, and economical analysis. This problem has not been adequately addressed by the DOE. The recently-issued revised SWECS siting handbook by Wegley, et al addresses the major issues.<sup>269</sup>

### Environmental Issues

Although a number of potential environmental issues have been identified which could possibly limit the development of the technology, most of these potential problems can be mitigated by careful site-specific evaluation prior to siting. The major issues are electromagnetic interference, noise, construction impacts, bird strikes, land use, aesthetics or public acceptance, and safety.

Electromagnetic interference of radio, TV, and microwave signals does not appear to be a significant problem. The ability of a wind turbine to scatter electronic signals depends on the rotor swept area and on the blade material. Large wind turbines with all-metal blades offer the greatest potential for scattering signals but remote siting will alleviate most problems. Non-metallic blades will further reduce the severity of the problem. TV and microwave interference could be a problem in rural areas where reception is weak, if the turbine is located in close proximity to a TV receiver or a microwave link. The TV interference can be solved by installing cable TV, and the microwave interference problem can be solved by installing the wind turbine outside the narrow zone where signals will be affected.

Noise in the audible range and infrasound do not appear to be a problem, except perhaps for certain types of large-scale systems located near populated areas or for small scale systems located in urban and suburban areas. Experimental measurements of sound levels near the 125 foot (38.1 meter) diameter, 100 kilowatt MOD-0 indicated that no significant problems exist; however, recently, noise problems have been encountered in connection with the 200 foot (61 meter) diameter, 2,000 kilowatt MOD-1 at Boone, North Carolina. The machine is a two bladed, downwind turbine with a truss tower. Residents have complained about the noise, and NASA is currently investigating the situation. The problem appears to result from the fact that a blade passes behind the tower at a frequency of about one cycle per second. Each time this occurs a blade passes through the turbulent



wake caused by the wind flow around the tower legs, and the resulting interference produces sound pressure fluctuations. These disturbances are focused and amplified by the terrain with the result that some of the nearby inhabitants are disturbed. NASA has curtailed operations and is installing a lower-speed generator. The problem can be corrected by design changes (changing the tower shape, changing the rotor rpm, or mounting the rotor in an upwind configuration) or by siting wind farms using large machines a sufficient distance from populated areas.

Construction impacts associated with land leveling and tower foundation appear to be minimal, although siting in forest areas or fragile ecological areas could produce some problems.

Bird strikes do not appear to be a problem. Observation with the MOD-O indicated that birds tend to take evasive action to avoid hitting the blades. Further test experience will provide more information for this question.

Land use could be a problem in the event that the potential site conflicts with other uses. Residential wind systems in densely populated urban and suburban areas appear to offer substantial problems owing to the relatively large blades and tall towers, although this may be more a question of safety and aesthetics. In the case of remotely sited wind farms, the wind machines and associated roads and service facilities would occupy a very small percentage of the land area (less than five percent) so that wind farms could coexist with other land uses such as cattle grazing. Only in the case of conflict with a wilderness area, park, or other scenic or valuable resource would there be a potential problem. Wind farms may be excluded from these areas and from sites in close proximity to densely populated residential areas.

A large portion of the U.S. wind resource is located on federal lands with wilderness potential. Many of these lands administered by the Bureau of Land Management (BLM) and the U.S. Forest Service will soon be classified by Congress according to land use designation. If detailed wind resource assessment surveys are not conducted prior to this land use designation, vast wind resources could be inadvertently locked up and forever precluded from development. Congress should appropriate adequate funding to make a preliminary resource assessment on federal lands. The task would cost about \$100 million over a period of two to three years and could result in the discovery of vast wind resources. Informed decisions could then be made regarding the ultimate designation of these federal lands. The California Energy Commission is currently working cooperatively with the BLM to begin to assess the wind resources in the 25,000 square mile (64,749.7 square kilometer) California desert. The BLM has agreed to permit wind resource measurements on all California desert lands which it administers. Federal funds will be required to continue to job initiated by the Commission. This project could be a pilot project that could pave the way for similar projects on all of the vast lands managed by BLM and the Forest Service.

Safety is of concern owing chiefly to the possibility of accidental structural failure of blade or tower elements. Large wind turbines are being designed to survive 125 mile per hour (201.2 kilometer per hour), hurricane force winds. In the event of a tower collapse a distance equal to the tower height plus rotor diameter would be affected, hence public access should be restricted from this area. Blade failure resulting in a thrown blade could thrust a large blade approximately 550 feet (167.6 meters) according to NASA analysis.<sup>270</sup> Rigorous design requirements, testing, and preventive maintenance could reduce the failure rate so as to pose a very small risk to human life. Remote siting and the fact that these failures would likely occur during extreme environmental conditions would further reduce the likelihood of any risk. Some certification and licensing of systems should be required to prevent unsafe designs from being sold. The DOE Rocky Flats SWECS test center in Colorado is an excellent location to test survival of small wind systems owing to the annual occurrence of 100 plus mile per hour (160.9 plus kilometer per hour) winds during winter storms.

### Legal and Institutional Issues

There are a variety of legal and institutional issues confronting full-scale development of wind energy, and the problems vary for large and small scale wind systems. A question arises over the issue of "wind rights." Upwind obstructions, such as buildings or other wind turbines, could seriously impede the airflow and limit the amount of energy available. Existing statutes do not cover this area, and as matters now stand, potential wind system owners would have to purchase preclusionary interest or "easements" in the surrounding land to assure adequate availability of wind energy for their turbine(s). This impediment will be of primary concern in urban or suburban areas. For the wind farm application and the land requirement for adequate spacing between turbines forces the wind farm developers to obtain wind rights for large parcels of land, although the ownership and use of the land are between the turbines could remain as it was prior to the wind farm development.

For the small-scale systems there are a number of institutional issues that may severely limit system implementation. Zoning restrictions such as limitations on height, setback, use, and aesthetics could severely restrict residential and commercial wind systems in urban and suburban areas.<sup>271</sup> Building, safety, and housing codes, although not likely to totally preclude wind turbine use, could impose substantial burdens on the user.<sup>272</sup> It is unlikely that utility applications are subject to these regulations and codes, since the utilities are regulated by state public service or utility commissions or are covered by state power plant siting statutes.

There are a number of utility interface issues that directly and substantially affect the small-scale system user. For utility-connected systems the chief issues are interconnection requirements and utility rates for purchase of unused power. The utility will require the user to install and maintain control and protective devices to permit the safe operation of the SWECS in parallel with the utility's generation facilities. Utility conservatism in this area may initially place a heavy

burden on the SWECS user. As more experience is gained, these requirements will be less costly and cumbersome. The issue of buyback rates is another very important consideration for interconnected systems. The Federal Public Utilities Regulatory Policies Act of 1978 (PURPA) requires utilities to purchase power from small producers unless the purchase would result in a net loss to the utility. Each state public utility commission must issue regulations regarding these rates. The producer is to be guaranteed a rate equal to the utility's avoided cost which translates to the marginal cost to generate an additional kilowatt hour of electricity. The utility will be required to revise the buyback rate each quarter to reflect changes in the marginal cost of energy.

Another issue that could have a strong influence on the economic viability of SWECS is the cost of insurance premiums to cover destructive loss of the wind turbine by acts by God, vandalism, or misuse. The annual cost to obtain this coverage could be a significant factor contributing to the cost of the electricity produced.

Finally, the lack of a well developed, sophisticated, and adequately financed manufacturing, distribution, installation, and servicing infrastructure for the wind industry is a very serious impediment to the expansion of this technology.

#### Trends (3.13-6)

At the present time the price that either a utility or a residential owner could pay for wind systems and break even over the system lifetime are off by approximately a factor of 1.5 to 2.0.<sup>273</sup> Under the present economic situation and assuming that oil prices escalate at three percent above the rate of inflation, the market for both utility and residential wind systems should emerge by the mid 1980s. Assuming that the technical performance and reliability of these systems is demonstrated, the value of electricity produced from these systems will be equal to or less than the value or cost of the fuel oil displaced. The market is not yet developing owing to currently high capital cost of these systems and the uncertainty of the potential buyer about system performance and reliability. Potential buyers of these systems are waiting until the cost comes down and performance is proven, while the manufacturers are not tooling up for mass production because the orders are not yet sufficient to warrant it. Various incentive measures can help to remove this barrier by reducing the risks to both the buyer and the manufacturer.

Currently there are several federal incentive measures recently passed in the U.S. Congress. The 1980 Crude Oil Windfall Profits Tax Act provides for a 40 percent tax credit for the first \$10,000 of a residential wind turbine system. For business investments in wind systems, a fifteen percent tax credit is available in addition to the existing ten percent investment tax credit for a total credit of twenty-five percent. In addition to this legislation the Congress recently passed the Wind Systems Act of 1980 which sets a national goal of 800 megawatts of installed wind system capacity by 1988. The Act provides incentives in the form of subsidies and loans to encourage the purchase and testing of wind systems.

The Act specifies subsidies initially equal to 50 percent of the capital cost for large-scale wind systems and low-interest loans for 320 megawatts of wind farm projects. The Act calls for a program to procure and install wind systems at federal facilities, and establishes a three year wind resource program funded at ten million dollars during the first year. The Act authorizes \$100 million; however, Congress has not yet appropriated this level of funding for Fiscal Year 1981. The direct federal purchase of wind systems could be very helpful in stimulating an early market, particularly demonstrations of large wind systems by the Water and Power Resources Service (formerly the Bureau of Reclamation) and the federal power marketing agencies such as the Bonneville Power Administration.

Various regulatory actions such as PURPA are also a stimulus to commercialization. PURPA is a vehicle by which small power producers can deliver up to 80 MW of power to a utility and avoid regulation by state public utility commissions while at the same time receiving the utility's avoided cost for the energy delivered. State utility commissions can do a great deal more to stimulate utility investment in wind systems by allowing an increased rate of return on investment for wind farm systems or by artificially increasing the cost of oil fired generation and plowing the increased revenues into wind farm deployment. The California Public Utilities Commission offers for example, an extra one half percent to one percent return on investment for renewable energy systems. This trend should be increased in the future by as much as five to seven percent to stimulate more rapid investment by utilities. The ratepayers would benefit from secure electricity prices from wind systems.

Accelerated depreciation is another incentive that is beneficial to utilities and businesses that invest in wind energy property. The trend will probably be to allow for much faster tax write-offs, for example, three years as opposed to seven years to depreciate an item of wind energy property, although the actual system lifetime is anticipated to be 20 to 30 years. Recently California enacted a law which allows a twelve to sixty month amortization for alternative energy equipment, including wind energy systems (Chapter 1327, Revenue and Taxation Code, 1980 Statutes).

### Sizing (3.13-7)

The issue of sizing is most appropriately discussed in terms of the application. Utility wind farms employing clusters of medium- or large-scale WECS could be considered a "centralized" application, while residential and other applications employing single units or clusters of several units in unit sizes from several kw to large-scale systems in the megawatt class could be considered a "decentralized" application. The "centralized" category does not fit the traditional definition since the wind farm may be quite small in comparison to a large, centralized nuclear, coal-, or oil-burning plant ranging in capacity from 500 to 2,000 megawatts. In comparison, a small wind farm might consist initially of ten MOD-2 units rated at 2.5 megawatts each, totaling 25 megawatts. Later, as more experience is gained the farm might consist of 32 MOD-2 units or 20 WTS-4 units totaling 80 megawatts. The land area requirements for an 80 MW wind farm are summarized in Table 3.13-2.

Table 3.13-2 <sup>274</sup>

80 MW WIND FARM LAND AREA REQUIREMENT AND NUMBER OF UNITS

<u>Model</u>	<u>Unit Rating Kilowatts</u>	<u>Rotor Diameter (feet)</u>	<u>Farm Area*</u>	<u>Number of Units</u>
Hamilton- Standard WTS - 4	4000	225	4.7	20
Westinghouse MOD-OW	500	125	7.3	160
Jay Carter 125	125	64	9.4	640
Jay Carter 25	25	32	11.75	3200

\*assumes ten diameter spacing between units

Table 3.13-2 also illustrates the fact that increasing the rotor diameter not only decreases the number of machines required for a given number of megawatts of total capacity, but decreases the land area required. For these reasons the large units appear to be more attractive assuming the cost per installed kilowatt is approximately equal for all these systems. Since the wind farm covers a much larger land area than a conventional power plant of comparable size, or alternately, the same land area as a conventional plant of ten times the capacity, this "centralized" application can be considered less centralized than conventional large central station fossil or nuclear plants.

Another way to explain this distinction is the following example: Consider two alternative means to satisfy the total U.S. electrical demand of  $2 \times 10^{12}$  kwh (two trillion kwh). Alternative 1 specifies 1,000 megawatt coal or nuclear stations operating at an average capacity factor of .60. Alternative 2 calls for 80 megawatt wind farms operating at an average capacity factor of .25. Table 3.13-3 illustrates the fact that over 30 times as many wind farms would be required to satisfy the U.S. electrical demand as compared to large centralized fossil or nuclear plants.

Table 3.13-3 275

NUMBER OF PLANTS REQUIRED TO SATISFY U.S. ELECTRICAL DEMAND

<u>Alternative</u>	<u>Plant Size, MW</u>	<u>Capacity Factor</u>	<u>Number of Plants</u>	<u>Land Area Square Miles</u>
Alternative 1: Centralized Conventional	1,000 MW	.60	380	1,900
Alternative 2: "Centralized" Windfarm	80 MW	.25	11,428	53,712 (1) 3,571 (2)

Notes:

- (1) Total Farm Area assuming four MW units, ten diameter spacing
- (2) Land dedicated exclusively to wind machines, roads, and facilities assuming ten acres per four MW unit

In terms of vulnerability, wind farms would be less vulnerable to attack or sabotage owing to the fact that there would be 30 times as many plants and the individual units would be dispersed over a larger area. Since the individual wind turbines would be separated by about one-half mile, each of these would represent a separate target. Thus, for a conventional (non-nuclear) attack, the wind farms would pose over 228,000 individual targets as opposed to the 380 targets offered by the conventional plants. As the individual unit size decreases, the number of individual targets increases. This is summarized in Table 3.13-4. At some point it no longer becomes "cost-effective" for a potential aggressor or saboteur to destroy this many targets.

Table 3.13-4 276

WIND SYSTEMS AS POTENTIAL TARGETS

<u>Targets</u>	<u>Unit Size, MW</u>	<u>Number of Individual</u>
Alternative 1	1000 MW	380
Alternative 2	4 MW	228,560
Alternative 3	500 kw	1,828,480
Alternative 4	125 kw	7,313,920
Alternative 5	25 kw	36,569,600

The "decentralized" on-site applications involving single units appear to be less cost-effective than the wind farm application owing to the fact that site selection and preparation, operation and maintenance will be more expensive, the site



resource may not be as energetic, and the institutional barriers may be more prohibitive. For a scenario in which wind systems capture fifteen percent of U.S. electrical demand (1.02 Quads primary energy displacement, 300 billion kilowatt hours per year) the contribution from "decentralized" wind systems will be at most about ten percent of this amount or 1.5 percent of U.S. electrical energy demand (.1 Quads, 30 billion kwh per year). This amount of energy could be supplied by 600,000 machines rated at 25 kw each, or 1,500,000 units rated at ten kw each. Assuming a total year 2000 U.S. energy demand of 100 Quads, "centralized" wind applications would supply for this scenario about 2.4 percent, while "decentralized" wind would supply less than .3 percent of the total energy.

### Potential for Decentralization and Community Self-Sufficiency (3.13-8)

There are numerous non-grid applications of wind systems for the remote or isolated energy consumers. Since many of these isolated users currently pay more than ten cents per kilowatt hour for electrical energy, this is a ready market for WECS. Non-grid-interconnected applications include telecommunications, isolated utilities, offshore oil and gas platforms, onshore oil and gas pipelines, defense installations, navigational aids, rural residences, and farms—all totaling perhaps more than two million wind systems of various sizes.<sup>277</sup> However, each application is constrained by the need to provide energy storage systems. Many types of energy storage systems have been proposed for use with wind power systems; however, many of these options, such as hydrogen, thermal, flywheel, and compressed air storage systems, are in the conceptual or early experimental stage and their associated energy storage costs are not well defined.<sup>278</sup> Assuming the average size of wind systems in this market sector is eight kw and capable of supplying 15,000 kw annually in a wind regime of twelve miles per hour (19.3 kilometers per hour) annual average wind speed, then two million individual applications would supply approximately 30 billion kilowatt hours annually, or about 1.5 percent of the U.S. electrical demand.

The key to maximum utilization of wind energy and maximum oil savings rests with the use of grid-integrated wind systems. Without some form of energy storage system, these WECS will probably be limited to ten to twenty percent penetration of the electric supply as fuel savers. One very promising approach for avoiding the temporal, seasonal, and geographic limitations of more extensive deployment of wind technology is through the use of hybrid or integrated systems of renewables technologies which incorporate WECS with other renewables such as wind/hydro, wind/biomass, or wind/solar/hydro.<sup>279</sup> The wind-hydro integration combination appears to be particularly attractive. Two alternates are possible: 1) use of wind for peaking, by conserving water during periods when the wind is blowing for controlled release later through the hydroelectric turbines during peak demand periods, and 2) using wind to pump water to a higher reservoir during base demand time and release of the water to generate power during peak demand.

Community self-sufficiency becomes a distinct possibility for certain locales that possess the "correct" blend of renewable energy resources. Wind, or any single

solar or renewable resource, taken alone, cannot provide self-sufficiency; however, a hybrid combination of two or three renewables does offer this possibility. A community must first identify its renewable energy resource potential, then consider scaling and compatibility of various renewable technologies, examine engineering feasibility, consider load management, costs, financing, institutional and legal factors, and community access and acceptance. Wind energy used in conjunction with hydro, biomass, geothermal, and possibly solar photovoltaic (when this alternative becomes less expensive) offers some promise for community self-sufficiency.

In New Hampshire, a feasibility study is underway to investigate the use of wind in conjunction with an upgraded 750 kw hydro site to provide for reliable year-round cost-effective operation. In the absence of wind, the hydro facility can operate only for about eight months of the year. The wind turbine would probably be used in the pumped storage mode to stabilize peak energy requirements needed during the winter nights. The wind turbine will be interfaced with the utility for backup in the event of a drastic lack of water or wind availability. Even for a "self-sufficient" application such as this, there is still a need to inter-face with the utility both to assure reliable power at all times and to provide for a means to sell unused power. There are approximately 9,600 potential small hydro sites in New England with an estimated total capacity of nearly 1,800 MW where wind/hydro integration could possibly be undertaken. Other regions in the U.S. are similarly endowed.

Another example of community self-sufficiency is Cuttyhunk Island, Massachusetts where a 200 kw wind turbine prototype developed by WTG Energy Systems, Inc., is operating in conjunction with the island's independent utility grid system. The island's municipal utility is diesel-electric with an installed capacity of 465 kw. Currently the island consumes 330,000 kwh per year. The wind turbine will provide most of the electricity except during the summer months when the diesel will be required to meet demand. WTG Energy Systems estimates that 500 small diesel utilities in the U.S. are located in high wind areas.<sup>280</sup>

Other examples of island installations of single large wind turbines are the DOE/NASA MOD-OA 200 kw systems located at Block Island, Rhode Island; Culebra, Puerto Rico; and Oahu, Hawaii.

A community that pays high fuel costs for electricity and is located near a windy area could develop its own wind farm either through its municipal utility or through a wind farm development company. The electricity could be "wheeled" to the community or sold to a regulated utility. The community would still be interconnected with the utility network and would require the utility to supply firm power when the wind farm was not generating power. Although not an example of self-sufficiency in the strict sense, this application would eventually provide a reduction in utility bills when oil costs escalate beyond the cost of wind electricity.

## Wave Energy (3.14)

Ocean waves possess tremendous energy, and finding ways to capture this energy for man's benefit have occupied inventors for many years. Numerous concepts have been designed and tested but only recently has significant technical progress resulted. Unfortunately, the few operating devices that have been built have provided only about a kilowatt of power.

It has been estimated that the total wave energy contained in the oceans equals about 300 trillion kilowatt-hours.<sup>281</sup> Because of its diffuse nature, its low or highly variable magnitude and its remote locations, only a fraction of that energy is available for conversion. For these reasons, large-scale wave energy power plants do not currently exist. However, in those countries where wave energy potential exists, there has been some effort to develop large-scale converters. The most ambitious programs to date have been undertaken by the British and Japanese. Other countries such as the United States, France, Germany and Canada have programs but these are not as extensive.<sup>282</sup>

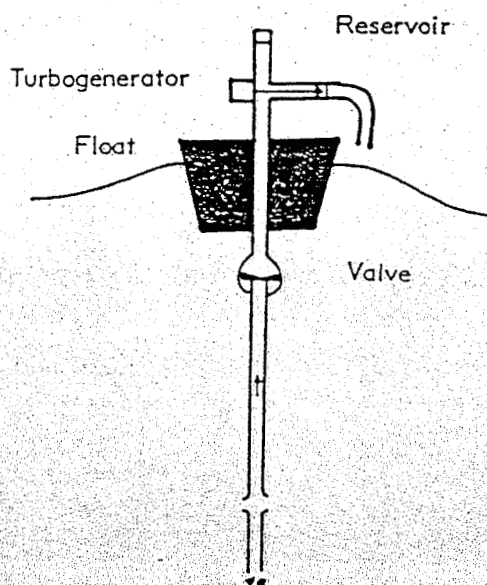
The extraction of energy from ocean waves is not a new concept. Many designs have been proposed, built and tested ranging in size and complexity from so-called wave motors that power buoys, to large installations that are intended to power cities. In a recent British study, it was reported that the development of wave power is technically feasible and could be achieved by the use of existing technology.<sup>283</sup>

Wave energy converters can be divided into five categories: wave pumps, pneumatic devices, motion devices, underwater pressure field devices, and facilities operated by the mass transport of water from breaking waves.

The wave pump is a simple device designed at Scripps Institute in La Jolla, California. Figure 3.14-1 illustrates this device.

Figure 3.14-1 284

### SCRIPPS WAVE GENERATOR



It consists of a long tube attached vertically to a float. The tube and float sink with passing wave troughs, causing water to be forced upward into the tube. A one-way check valve prevents water from flowing back on the crest of the wave. After repeated wave cycles, the water is raised to a level where the pressure is suitable for power generation. Models of the device have yielded an estimated power of 60 watts at an efficiency of fifteen percent.<sup>285</sup>

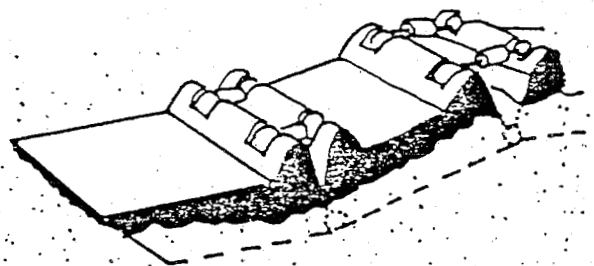
The most notable effort in pneumatic conversion devices has been made by the Japanese with the Masuda design. It is presently employed in over 300 navigation buoys and lighthouses in Japan. The British Oscillating Water Column (OWC) is a slight modification of the Japanese model. Basically it is an upturned canister with an air bubble above the water line and a hole in the side or on the top. As the waves rise and fall, air inside the canister is pushed out and sucked in through the hole. This drives an air turbine which is linked to a generator. The overall efficiency is estimated at about 50 percent.<sup>286</sup> The U.S. Coast Guard has tested the wave-powered buoys and found that they would be suitable for the use of Coast Guard floating aid devices.

With the development of the Salter Nodding Duck and the Cockerell Raft, England may some day utilize its huge wave energy resources. The Nodding Duck design is so-called because the beaks bob up and down with the waves. It consists of a row of cone-shaped vanes strung sequentially in a line. This axis displaces very little water and is thus very efficient. It is able to extract as much as 90 percent of the available energy.<sup>287</sup>

The Cockerell Raft utilizes a chain of floats or rafts, hinged together (Figure 3.14-2).

Figure 3.14-2 288

#### THE COCKERELL RAFT



These oscillate up and down successively with the changing slope of the passing waves. Pumps on the hinges absorb the power of the oscillations and convert the energy into fluid pressure which drives a turbine. Tests have yielded efficiencies of about 90 percent.<sup>289</sup>

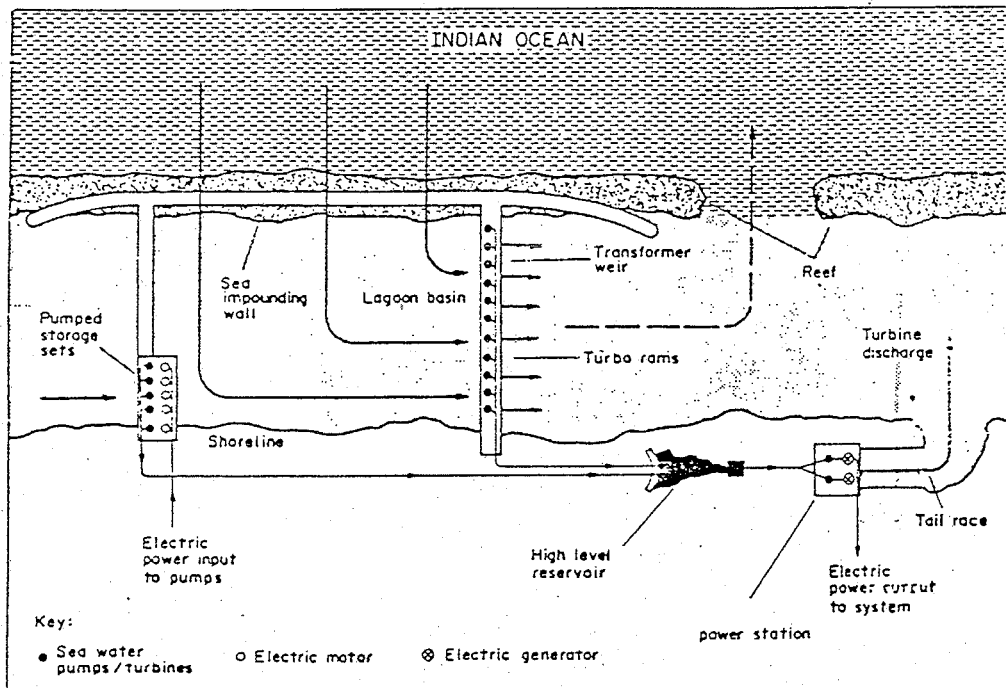
Underwater pressure field devices have been built and designed for buoys both in the United States and Germany. Such devices convert wave energy through transformation of hydrostatic pressure changes. The changes in pressure are sensed by the sub-surface or bottom-mounted converters as the waves pass overhead.



Wave energy devices utilizing the mass transportation of water were among the earliest wave power schemes developed. Figure 3.14-3 illustrates a design for a system in the Indian Ocean.

Figure 3.14-3 290

A WAVE ENERGY SYSTEM



Onrushing water from breaking and shoaling waves is channeled into storage basins. The head of water thus developed is used to operate a low head turbine as it returns to the level of the sea. At present, only one facility has been proposed. This facility would be located on the island of Mauritius, where swells arrive uniformly throughout the year. The design of this facility, however, is slightly different. The head developed in the storage basin is only a few feet and a hydraulic ram is used in place of a turbine. Water from the ram is pumped to a higher reservoir. There a turbine utilizes the higher head to generate power and returns the water to the ocean.<sup>291</sup>

The United States shoreline is buffeted by waves which vary considerably with the season and geographic location. The shores of the Pacific Northwest demonstrate on the average, the most consistent wave conditions along the continental U.S., thus the Oregon-Washington coast offers the greatest potential for wave energy in the U.S. Estimates of power production range from a high of sixteen megawatts per kilometer of coastline during December, to a low of five megawatts per kilometer during August, with a yearly average of 11.5 megawatts per year. This can be compared to the conditions on the Gulf of Mexico with .8 megawatts per kilometer in April to .2 megawatts per kilometer in August and a yearly average of about .5 megawatts per kilometer. When multiplied by the respective coastline length, these averages yield a total potential wave power ranging from over 87,000 megawatts on the Washington-Oregon coastline to about 10,000 megawatts on the Gulf of Mexico coastline.<sup>292</sup>

In terms of wave energy potential, Britain is much more fortunate, with a stretch of ocean between 600 to 1,400 miles (965.6-2,253.1 kilometers) long capable of providing almost half of its total energy requirements.<sup>293</sup>

The slow development of wave energy technology stems from technical and economic problems. A major technical problem relates to the difficulties of mooring the devices. Wave power facilities must be very large and durable enough to withstand the constant pounding of the waves. Experience with offshore oil platforms may be helpful in designing a suitable type and size mooring, but the costs of a suitable mooring system may still be prohibitive for some time. Only when a safe, reliable and cheap method for mooring is developed will wave power be able to compete with conventional energy sources.<sup>294</sup>

Underwater transmission lines also contribute to the high costs of wave power facilities, although most estimates place a plant only four or five miles (6.4 or 8 kilometers) from shore and therefore transmission costs may pose less of a problem than mooring.

A lack of funding has impeded development of a wave energy program in the United States. For the first time, the funding for government-sponsored research is above \$1 million. If it is to be a part of the national energy program, wave power must receive a substantial increase in government funding.<sup>295</sup>

In the United States, a wave power program exists under the Division of the Ocean Energy Systems of the Department of Energy and is administered by the Solar Energy Research Institute (SERI). The program consists of providing technical expertise and cooperation with Japan, Britain and other countries for the advancement of wave power. Development of wave focusing devices and an air turbine for the Oscillating Water Column is also slated under the United States program. At present, funding for 1980 stands at about \$1.1 million; this may double by 1985. A working model generating between one and five megawatts is also planned to be put into operation by 1985. Beyond this, however, there are no large scale development plans for the future.<sup>296</sup>

There are environmental issues that must be addressed with wave energy production. The altering of local wave conditions could reduce wave action on the shore although it is difficult to assess the effects this might have since little research has been done in the area. Also, with increased commercialization, the oceans and thus the shorelines would be subject to increased industrialization. The effects of these impacts must be examined before any development is undertaken.<sup>297</sup>



## Conclusions (3.15)

Increasing the nation's energy security through accelerated conservation efforts and approaches designed to increase self-sufficiency through the use of alternative energy technologies has been outlined in Section 3. Solar and renewable energy technologies cannot be expected to meet national needs immediately, but through a phased program, the nation's national security can be enhanced and goals for energy self-sufficiency reached.

Moving towards a less centralized energy and resource system would require both a national will to do so (expressed politically and economically), and a mechanism for funding. The Battelle Memorial Institute has conducted a substantial research effort for the Department of Energy aimed at understanding the present U.S. system and the history of providing incentives to stimulate energy production from conventional sources. Table 3.15-1 summarizes this research, which has tabulated \$252 billion in subsidies and incentives for coal, oil, hydro, nuclear, gas and electricity. The study concludes:

...That a precedent exists for utilizing Federal incentives to increase energy production. Design of national energy policy which considers the results of Federal investment in incentives to increase energy production could be an efficient basis upon which to integrate current and impending technology, existing energy stocks, and consumer requirements and preferences. The conclusion of micro-economic solar energy feasibility studies could be inconsequential without a comprehensive understanding of the costs and results of incentives to increase energy production. This is so because of the disparity in rationale between the Federal Government and the private sector. The Federal Government need not predicate national policy on short-term micro-economic analysis. As confirmed by this study, Federal justification is predicated on long-term goals met with the aid of new technology and supported by social values of the nation. If it is socially desirable and technologically feasible to increase solar energy's share in the national energy budget, the paramount policy question is one of selecting an incentive strategy and determining the government's level of investment in it.<sup>298</sup>

Table 3.15-1299

AN ESTIMATE OF THE COST INCENTIVES USED TO  
STIMULATE ENERGY PRODUCTION (IN BILLIONS OF 1978 DOLLARS)

	<u>Nuclear</u>	<u>Hydro</u>	<u>Coal</u>	<u>Oil</u>	<u>Gas</u>	<u>Electricity</u>	<u>Total</u>	<u>Percent of Total Incentives</u>
Taxation	—	2.0	4.74	55.48	14.92	38.83	115.97	46.0
Disbursements	—	—	—	1.30	—	—	1.30	0.5
Requirements	1.7	0.04	0.80	57.49	-0.80	—	59.23	23.5
Traditional Services	—	—	2.57	6.92	—	0.52	10.01	4.0
Nontraditional Services	17.2	—	3.55	1.88	0.30	—	22.93	9.1
Market Activity	<u>2.1</u>	<u>14.86</u> <sup>(a)</sup>	—	<u>0.02</u>	<u>0.50</u>	<u>0.15</u>	<u>25.17</u> <sup>(a)</sup>	<u>42.80</u>
Totals	21.0	16.90	11.68	123.57	14.57	64.52	252.24	100
Percent of Total Incentives	8.3	6.7	4.6	49.0	5.8	25.6	100	

(a) This Value based on incentive definition 1 (Federal money outstanding).

As has been noted in prior sections of this report, numerous studies have suggested varying levels of funding for alternative energy sources, conservation, dispersed power plants, etc. Former Joint Economic Committee Energy Director, Jerry Brady, suggests a modest beginning:

If we took one-half (of the national \$20 billion per year in various conventional energy subsidies), or \$10 billion, and redirected it for just ten years at a total cost of \$100 billion, we could provide interest-free loans sufficient to insulate half the homes in America. According to Rosenfeld, (of the Lawrence Berkeley Laboratory) the savings would amount to approximately 10 Quads a year, or roughly 75 percent of the heat content of oil now imported to the U.S. This should be compared to the \$88 billion synfuels program, which will produce no more than 15 percent of the oil we now import by the year 1990.<sup>300</sup>

This study concludes that the strategic viewpoint on decentralization of energy sources must take into account two major time frames if the issue of energy and national security is to be appropriately addressed:

1. The Short-range Strategy (current to twenty years)

During this period, acceleration of government programs and incentives can result in the increase of community self-reliance by incorporating a range

of dispersed and renewable energy sources with increasing decentralization of electrical grids and fuel transportation systems. Some methods to increase this process and utilize civil defense and emergency planning programs are discussed later in this section.

## 2. The Long-range Strategy (twenty to seventy years)

The activities and programs undertaken by communities in the short-range to increase community self-reliance and accelerate the use of renewable and dispersed energy sources can pave the way towards a more comprehensive re-orientation of the society's energy organization over a longer time-frame. Whereas during the short-range implementation period the greatest gains are in replacing and substituting conventional and centralized resource supplies, the long-range strategy allows for the development of major new systems which can operate largely on renewable sources of energy (solar, wind, hydro, biomass, etc.).

One recent study conducted by the Union of Concerned Scientists addressed this question and the results of their scenario for energy supply and demand in the year 2050 (70 years hence) are provided in Table 3.15-2.

Table 3.15-2<sup>301</sup>

### ENERGY SUPPLY AND DEMAND IN THE YEAR 2050 \*

ENERGY-USE ENERGY FORM	ENERGY SOURCE TECHNOLOGY	APPROPRIATE ENERGY SUPPLY	PERCENT	ENERGY REQUIREMENTS (in quads)		
				HIGH EFFICIENCY/HIGH POPULATION SCENARIOS	Current Standard of Living	Intermediate Standard of Living
Low-temperature thermal energy ( 100°C)	Direct solar energy	Passive and active solar heating and cooling, district heating systems	25	13	17	20
Intermediate to high-temperature thermal energy ( 100°C)		Flat-plate collectors stationary and tracking solar concentrators	25	14	17	21
Electricity	Direct solar energy	Photovoltaic, solar-thermal, and cogeneration systems	30-40	8-10	10-13	12-20
	Wind	Wind generators		8-11	10-14	12-20
		Subtotal		16-21	20-27	32
Liquid fuels	Biomass	Organic residues and wastes		3-5	3-7	3-5
Carbon feedstocks methane		Energy "plantations"	10-20	2-5	3-6	3-5
		Subtotal		5-10	6-13	8
		TOTAL	100	53	67	81

\*All demand estimates assume that we would use energy twice as efficiently on the average in 2050 as we do now. The "Current" standard of living case assumes that effective average per capita energy use remains unchanged while the "Intermediate" and "High" standard of living cases represent increases in effective per capita consumption of an average of 28% and 55%, respectively. The latter increase is equivalent to raising the average energy use of all U.S. citizens to levels now characteristic of only the upper 20 percentile income group.

Table 3.15-3<sup>302</sup>A PROPOSED LONG-TERM SOLAR ENERGY ECONOMY

DEMAND SECTOR	END-USE ENERGY FORM	APPLICATION	PERCENTAGE OF OVERALL ENERGY USE	APPROPRIATE ENERGY SUPPLY TECHNOLOGY
Residential and Commercial	Low-temperature thermal energy ( 100°C)	Space heating, water heating, air conditioning	20-25%	Passive and active solar system, district heating systems
	Intermediate-temperature energy (100-300°C)	Cooking and drying	5%	Active solar heating with concentrating solar collectors
	Hydrogen			Solar thermal, thermochemical, or electrolytic generation
	Methane			Biomass
	Electricity	Lighting, appliances, refrigeration	10%	Photovoltaic, wind, solar thermal, total energy systems
		Subtotal	35%	
Industrial	Intermediate-temperature thermal energy ( 300°C)	Industrial and agricultural process heat and steam	7.5%	Active solar heating with flat-plate collectors, and tracking solar concentrator
	High-temperature thermal energy ( 300°C)	Industrial process heat and steam	17.5%	Tracking, concentrating solar collector systems
	Hydrogen			Solar thermal, thermochemical, or electrolytic generation
	Electricity	Cogeneration; electric drive, electrolytic, and electrochemical process	10%	Solar thermal, photovoltaic, cogeneration, wind systems
	Feedstocks	Supply carbon sources to chemical industries	5%	Biomass residues and wastes or plantations
		Subtotal	40%	
Transportation	Electricity	Electric vehicles, electric rail	10-20%	Photovoltaic, wind and solar thermal-electric
	Hydrogen	Aircraft fuel, land and water, transportation vehicles		Solar thermal, thermochemical, or electrolytic generation
	Liquid fuels methanol, ethanol gasoline	Long-distance land and water transportation vehicles	5-15%	Biomass residues and wastes or plantations
		Subtotal	25%	
		Total	100%	

The UCS study concludes that the U.S. could complete a transition to a solar economy by 2050 and with proper incentives, could gain the equivalent of 12-28 Quads of energy by the year 2000. By 2050, renewable sources, ranging from passive and active solar heating, district heating, thermochemical, biomass, photovoltaic, wind and total energy systems would supply all energy needs in the residential, commercial, and industrial sectors. The end-use demands are shown in Table 3.15-3.

Given the dispersed nature of many renewable resources, the UCS study discounts the possibility of total system decentralization:

(Some degree of transmission will be absolutely necessary to provide energy for certain urban and industrial concentrations (such as Manhattan) where the density of energy use exceeds locally available solar and wind power. Furthermore the establishment of an integrated, nationwide electricity grid system could provide substantive benefits for a solar energy future by contributing to greater overall system reliability, minimizing requisite peaking power capacity, and reducing energy storage requirements.<sup>303</sup>

This study is an example of a complete synthesis of known renewable technologies, with a fair explication of their future potential. An essential feature of the study is an attempt to set a rational time frame for implementation of the system-wide changes to implement a fully renewable energy economy. Many current efforts assume that a renewable energy economy can be developed within a few years. These efforts do not take into account the substantial industrial, economic infrastructure, and social changes required.

The final section of this document is concerned with the important first steps to be taken to categorize the strategic energy technologies and resources required to increase energy security on a regional and local level.

### SECTION 3

#### DISPERSED AND RENEWABLE ENERGY SYSTEMS

##### FOOTNOTES

1. Energy Committee of the Aspen Institute for Humanistic Studies, Second Annual R & D Workshop, "Decentralized Electricity and Cogeneration Options," Aspen, Co., July 13-17, 1979.
2. Stobaugh, Robert and Daniel Yergin, "Energy and Emergency Telescoped," Foreign Affairs, Vol. 58:3, pp. 593-594.
3. Brady, J. and B. Zimble, "Conservation, Not Synfuels, Will Cut Oil Imports," Energy User News, August 18, 1980, p. 22.
4. Yergin, Daniel, "Conservation: The Key Energy Source," in Energy Future: Report of the Energy Project at the Harvard Business School, Robert Stobaugh and Daniel Yergin, ed(s)., Random House, N.Y., 1979, p. 166.
5. Table 3.2-1, "Residential Energy Consumption By Use," Source: Ibid., p. 9.
6. The Ford Foundation, "Energy Conservation: Opportunities and Obstacles," in Energy: The Next Twenty Years, Hans H. Landsberg, Chairman, Cambridge, Ma., 1979.
7. DOE/EIA, Monthly Energy Review, August, 1980, p. 17.
8. Yergin, op. cit., p. 154.
9. Brady and Zimble, op. cit., p. 1.
10. Yergin, op. cit., p. 152.
11. Gray, Charles L., "The Potential for Improved Fuel Economy Between 1985 and 1995," as quoted before the U.S. Senate Committee on Energy and Natural Resources.
12. "The Reluctant Revolution," Soft Energy Notes, August-September, 1980, pp. 3-5.
13. Table 3.2-2, "Future Fleet Possibilities," Source: Ibid., p. 4.
14. Table 3.2-3, "Opportunities for Technological Research and Development in Support of Energy Conservation," Source: Committee on Nuclear and Alternative Energy Systems (CONAES), National Research Council, Energy in Transition: 1985-2010, W. H. Freeman and Co., San Francisco, Ca., 1980.



FOOTNOTES (Continued)

15. The Ford Foundation, op. cit., p. 138.
16. Ibid., pp. 147-152.
17. Hayes, Dennis, "Energy: The Case for Conservation," Worldwatch Paper, Vol. 4., Worldwatch Institute, Washington, D.C., 1976, p. 8.
18. Office of Technology Assessment (OTA), Conservation and Solar Energy Programs of the Department of Energy: A Critique, U.S. Government Printing Office, Washington, D.C., 1980, p. 3.
19. Ibid., pp. 11-13.
20. California Energy Commission (CEC), 1979 Biennial Report, California State printing Office, Sacramento, Ca., 1979, p. 42.
21. Ibid., p. 35.
22. CONAES, op. cit., pp. 8-9.
23. Ibid., pp. 82-83.
24. Table 3.2-4, "Scenarios of Energy Demand: Totals," Source: CONAES, op. cit., pp. 82-83.
25. Figure 3.2-1, "Demand and Conservation Panel Projections of Total Primary Energy Use to the Year 2010 (Quads)," Source: CONAES, op. cit., p. 8.
26. Table 3.2-5, "U.S. Energy Consumption (Quads)," Source: U.S. Department of Energy, Energy Conservation: Program Summary Document, FY 1981, Chapter 2, Washington, D.C., February, 1980, p. 7.
27. Ibid., Chapter 2, p. 1, and Chapter 7, p. 21.
28. The Ford Foundation, op. cit., p. 123.
29. CONAES, op. cit., p. 4.
30. Ibid., p. 14.
31. Sant, Roger W., The Least-Cost Energy Strategy: Minimizing Consumer Costs Through Competition, Energy Productivity Center, Mellon Institute, Arlington, Va., 1979, p. 4.
32. Ibid., p. 5.
33. Ibid., p. 46.

FOOTNOTES (Continued)

34. "Putting Baseload to Work on the Night Shift," EPRI Journal, Vol. 5, No. 3, April, 1980, p. 6.
35. Ibid., p. 8.
36. PURPA, Sec. III, pp. 95-617.
37. Ibid., Sec. II5.
38. Cichetti, C. and J. Reinberg, "Electricity and Natural Gas Rate Issues," Annual Review of Energy, 1979, pp. 231-258.
39. Ibid., pp. 231-258.
40. Calsetta, Alfred B., Electric Utility Load Research Data Processing System, TVA, Gatlinburg, Te., October, 1979.
41. 1980 Conservation and Load Management Program, Southern California Edison Co., Rosemead, Ca., December, 1979, p. 205.
42. "Electrical Co-ops That Save Big Users Big Money," Business Week, August 4, 1980, p. 28.
43. Swet, C.J., "Seasonal Storage: Prospects and Problems," Lawrence Berkeley Laboratory, Thermal Energy Storage in Aquifers Workshop, May 10-12, 1979.
44. Lehr, Jay H., "Environmental Aspects of Low Temperature Thermal Energy Storage in Aquifers," Ibid., p. 34.
45. Cook, Earl, Man, Energy, Society, W. H. Freeman and Co., San Francisco, Ca., 1976, pp. 42-43.
46. Lehr, op, cit., pp. 35-36.
47. Science, May 17, 1974, p. 787.
48. Power, Vol. 123, No. 7, July, 1979, p. 43.
49. Science, May 24, 1974, p. 884.
50. Ibid., p. 885.
51. Post, Richard F. and Stephen F. Post, "Fly-Wheels," Scientific American, December, 1973, p. 17.
52. Ibid., pp. 19-21.
53. Ibid., p. 22.

FOOTNOTES (Continued)

54. Science, May 24, 1974, op. cit., p. 886.
55. Science, May 17, 1974, op. cit., p. 785.
56. Ibid., p. 785.
57. Figure 3.3-1, "Comparison of Energy-Storage Technologies," Source: EPRI Journal, op. cit.
58. Ibid., p. 6.
59. Figure 3.3-2, "German Load Management: 1968-1973," Source: Energy and Defense Project.
60. Asbury, J. G., R. F. Geise, and R. O. Mueller, "Electric Heat: The Right Price at the Right Time, Technology Review, December/January, 1980, p. 32.
61. Manufacturing Chemists Association, A Proven Way to Save Energy: Cogeneration, Washington, D.C., 1978, p. 2.
62. California Energy Commission (CEC), Commercial Status: Electrical Generation and Non-Generation Technologies, Sacramento, Ca., September, 1979, p. 208.
63. Ibid., p. 208.
64. Williams, Robert H., "Industrial Cogeneration," Annual Review of Energy, Vol. 3, Annual Review, Inc., Palo Alto, Ca., 1978, p. 319.
65. Ibid., p. 320.
66. Ibid., pp. 318-320.
67. Kaufman, Alvin and Barbara Daly, "Cogeneration--Problems and Outlook," Congressional Committee Report, Centralized vs. Decentralized Energy Systems: Diverging or Parallel Roads?, May, 1979, p. 200.
68. Figure 3.4-1, "Conventional Electrical and Process Steam Systems Compared to a Cogeneration System," Source: Department of Energy Resource Planning Associates, Inc., Cogeneration: Technical Concepts Trends Prospects, September, 1978.
69. Figure 3.4-2, "Diagram Illustrations of Topping Cycle Cogeneration Systems," Source: Ibid.
70. Williams, op. cit., p. 320.
71. Herman, Stewart W. and James S. Cannon, Energy Futures: Industry and the New Technologies, Inform, Inc., New York, N.Y., 1976, p. 659.

FOOTNOTES (Continued)

72. Table 3.4-1, "Distinguishing Features of Topping Cycle Cogeneration Systems," The Comptroller General, Report to Congress, GAO, Industrial Cogeneration: What It Is, How It Works, Its Potential, EMD-80-7, April 29, 1980, p. 8.
73. Ibid., p. 10.
74. Figure 3.4-3, "Alternate Topping Cycles: Potassium Turbines," Source: Ibid.
75. Figure 3.4-4, "Combined Cycle Topping System," Source: Ibid.
76. The Comptroller General, op. cit., p. 261.
77. Kaufman, op. cit., pp. 220-222.
78. TOTEM: Technical Description, Brooklyn Union Gas, October, 1978, pp. 1-2.
79. TOTEM: Total Energy Module, Fiat Auto Group, September, 1977, p. 2.
80. Ibid., p. 7.
81. Ibid., p. 9.
82. Ibid., p. 11.
83. Clark, Wilson and E. Bassignana, et al., Transcript of January 21, 1980, TOTEM meeting, California Governor's Office, Sacramento, Ca.
84. CEC, Commercial Status, op. cit.
85. Thermo Electron Corporation, "Proposal for a 60 kw Gas Total Energy Module Based Upon Low-Cost Automotive Engines," Waltham, Ma., May 31, 1979.
86. The Energy Daily, August 17, 1978, p. 203.
87. Dow Chemical Company, Energy Industrial Center Study, prepared for the National Science Foundation, June, 1975.
88. Table 3.4-2, "Total Potential Energy Savings From Cogeneration and Estimated Market Penetration (Quads)," Source: Ibid.
89. Fagenbaum, Joel, "Cogeneration: An Energy Saver," IEEE Spectrum, August, 1980, p. 30.

FOOTNOTES (Continued)

90. Morgan, D.T. and J. P. Davis, "High Efficiency Decentralized Electrical Power Generation Utilizing Diesel Engines Coupled with Organic Working Fluid Rankine Cycle Engines Operating on Diesel Reject Heat," Thermo Electron Corp., November, 1979, p. 72.
91. Herman and Cannon, op. cit., p. 268.
92. Energy Daily, op. cit., p. 2.
93. Dow Chemical Company, op. cit., p. 11.
94. Energy Daily, op. cit., p. 1.
95. Power Engineering, March, 1978, p. 311.
96. Ibid., p. 311.
97. California Public Utilities Commission, Utilities Division, "Staff Report on California Cogeneration Activities," San Francisco, Ca., January, 1978, p. 7.
98. Cricton, Kyle, "Prospects for Cogeneration," Energy User News, 1980, p. 8.
99. Kaufman, op. cit., p. 205.
100. Dow Chemical Company, op. cit., p. 15.
101. Considine, Douglas M., ed., Energy Technology Handbook, McGraw-Hill Book Company, New York, 1977, pp. 4-59.
102. Ibid.
103. CEC, Commercial Status, op. cit., p. 259.
104. Lang, Rich, Fuel Cells in California, CEC, Alternative Implementation Division, April, 1977, p. 3.
105. Ibid.
106. Figure 3.5-1, "Hydrogen-Air Fuel Cell Schematic," Source: OTA, Application of Solar Technology to Today's Energy Needs, Vol. 1, June, 1978, p. 422.
107. Considine, op. cit., p. 4-60.
108. Ibid.
109. Cook, op. cit., p. 47.

FOOTNOTES (Continued)

110. Clark, Wilson, Energy for Survival, Anchor Books, New York, 1974, p. 219.
111. Considine, op. cit., p. 4-60.
112. U.S. Department of Energy, (DOE) Solar, Geothermal, Electric and Storage Systems Program Summary Document, March, 1978, p. 207.
113. Ibid.
114. Cook, op. cit.
115. Clark, op. cit.
116. U.S. DOE, op. cit.
117. Electric Power Research Institute, 1980-1984 Research and Development Program Plan, February, 1980, p. 209.
118. Ibid., p. 212.
119. CEC, Commercial Status, op. cit.
120. Lang, op. cit., p. 8.
121. Clark, Wilson, Discussions with Chinese electric power officials--Beijing, Nangzhon, Guangzhon, April-May, 1980.
122. U.S. Army Corps of Engineers, National Program of Inspection of Dams, Office of the Chief of Engineers, Washington, D.C., May, 1975.
123. Institute for Water Resources, National Hydroelectric Power Resources Study, Preliminary Inventory of Hydropower Resources, Ft. Belvoir, Va., July, 1979.
124. Table 3.6-1, "Preliminary Inventory of Hydroelectric Power Resources National Total," Source: Ibid.
125. Ibid.
126. Ibid.
127. U.S. Department of Energy, Micro-Hydro Power, DOE/ET/01752-1, January, 1979, p. 28.
128. Ibid., p. 31.
129. Figure 3.6-1, "Rim-Generator Turbine," Source: Small-Scale Hydroelectric Power, DOE-NCAT, B-023-0379-1, .3M., p. 3.



FOOTNOTES (Continued)

130. Figure 3.6-2, "Bulb-Type Turbine," Source: Ibid., p. 3.
131. Figure 3.6-3, "Turbular-Type Turbine," Source: Ibid., p. 3.
132. Ibid., p. 3.
133. Office of Technology Assessment (OTA), Application of Solar Technology to Today's Energy Needs, Volume II, Washington, D.C., September, 1978, p. 754.
134. Anderson, Bruce, Solar Energy: Fundamentals in Building Design, McGraw-Hill, New York, 1977, p. 38.
135. Ibid., p. 39.
136. Mazria, Edward, The Passive Solar Energy Book, Rodale Press, Emmaus, Pa., 1979, p. 28.
137. Ibid., pp. 73-84.
138. Howell, Yvonne and Justin A. Bereny, Engineer's Guide to Solar Energy, Barnes and Nobel Books, New York, N.Y., 1979.
139. Antolini, Holly L., ed., Sunset Homeowner's Guide to Solar Heating, Lane Publishing Co., Menlo Park, Ca., 1978.
140. Barnaby, Charles S., Philip Caesar and Bruce Wilcox, Solar for Your Present Home, California Energy Commission, Sacramento, Ca., 1977.
141. Figure 3.7-1, "Liquid Flat Plate Space Heating System," Source: Mazria, op. cit.
142. Figure 3.7-2, "Air and Liquid Collectors," Source: Ibid.
143. Office of Technology Assessment (OTA), Application of Solar Technology to Today's Energy Needs, Vol. 1, Washington, D.C., June, 1978, pp. 508-509.
144. Young, Frank, Electric Power Research Institute (EPRI), telephone communication based on data from Overview and Strategies for 1981-1985 Program Plan, October 1980.
145. "Present and Future of Solar Cooling," Solar Engineering, June, 1979, p. 14.
146. Ibid., p. 14.
147. "Component Choice is Limited," Solar Engineering, May 1979, p. 22.

FOOTNOTES (Continued)

147. "Collectors for Solar Cooling," Solar Engineering, May 1979, p. 38
149. Scholten, William and Henry Curran, "Active Cooling Update," Solar Age, June, 1979, p. 38.
150. Solar Engineering, June, 1979, op. cit., p. 15.
151. Scholten and Curran, op. cit., p. 39.
152. Figure 3.7-3, "An Adsorption Chiller," Source: OTA, Vol. I, op. cit., p. 525.
153. Asbury, J. and R. Mueller, "Solar Energy and Electric Utilities: Should They Be Interfaced?" Science, February 4, 1977.
154. Figure 3.8-1, "Central Receiver System," Source: Energy and Defense Project.
155. Holland, Elizabeth, "About Mirrors, Troughs, and Dishes," Solar Age, July, 1979, pp. 8-9.
156. "Bartow Barely Escapes House Budget Cutback," Solar Engineering, July, 1980, p. 17.
157. Hildebrant, A.F. and L.L. Vant-Hill, "Solar Tower Energy Collector," Technology Handbook, Douglas Considine, ed., 1977, pp. 6-26.
158. Solar Engineering, July, 1979, op. cit., p. 17.
159. Anderson, Bruce, "For A Smooth Transition," Solar Age, January, 1980, p. 13.
160. Solar Engineering, July 1979, op. cit., p. 17.
161. Ibid., p. 17.
162. Holland, op. cit., p. 7.
163. Loftness, Robert, Energy Handbook, Van Nostrand Reinhold Co., 1979, p. 352.
164. "Prospects for Solar Industrial Heat," Solar Engineering, March, 1980, p. 22.
165. Ibid., p. 22.
166. Holland, op. cit., p. 8.

FOOTNOTES (Continued)

167. Ibid., p. 9
168. Bessler, Mike, "Potential Applications of Solar Salt Gradient Ponds for the Colorado River Water Quality Improvement Program," U.S. Department of the Interior, Denver, Co., June 1980.
169. Neilsen, Carl E., "Nonconvective Salt Gradient Solar Ponds," from Non-Convecting Solar Pond Workshop Proceedings, Desert Research Institute, University of Nevada, July, 1980.
170. Ibid.
171. Wittenberg, Layton J. and Marc J. Harris, "City of Miamisburg Heats Pool with Salt Gradient Solar Pond," Solar Engineering, April, 1980, pp. 26-28.
172. Ibid.
173. Ormat Turbines, Ltd., "The Solar Pond Development Program in Israel," From Non-Convecting Solar Pond Workshop Proceedings, op. cit.
174. "Salton Sea Study to Determine Electrical Generation Potential," Solar Engineering, April, 1980, pp. 20-24.
175. "Dead Sea Project to Supply Multi-Megawatts of Power," Solar Engineering, April 1980, p. 24.
176. The California Governor's Office of Planning and Research in cooperation with the California Department of Water Resources, The California Water Atlas, 1979.
177. Figure 3.8-3, "Salton Sea Solar Pond Concept" Source: Solar Engineering, April, 1980, p. 20.
178. Ormat Turbines, Ltd., op. cit.
179. Ibid.
180. OTA, Renewable Ocean Energy Sources, Part I, Washington, D.C., May, 1978, p.7.
181. Figure 3.9-1, "Diagram of An Ocean Thermal Energy Conversion System," Source: "Power from the Sea," Rand Research Review, Vol. IV, No. 2, Rand Corporaton, Santa Monica, Ca., 1979.
182. CEC, Commerical Status, op. cit., p. 168
183. OTA, Renewable Ocean Energy Sources, op. cit., p. 21.
184. Ibid., p. 19.

FOOTNOTES (Continued)

185. Ibid., p. 23.
186. Figure 3.9-2, "S.S. Ocean Energy Converter," Source: "S.S. Ocean Energy Converter Dedicated," DOE News, July 5, 1980.
187. Ibid.
188. OTA, Application of Solar Technology to Today's Energy Needs, Vol. 1, op. cit., p. 25.
189. Monegon, Ltd., The Future of Solar Electricity, 1980-2000: Developments in Photovoltaics, Gaithersburg, Md., January, 1980, p. 42.
190. Backus, Charles E., Photovoltaics in the 1980's, Vol. 3.2, American Section of the International Solar Energy Society, Inc., Proceedings of the Annual Meeting, Phoenix, Arizona, AS/ISES, 1980.
191. Table 3.10-1, "Key Milestones for National Photovoltaic Conversion Program," OTA, Application of Solar Technology to Today's Energy Needs, Vol. 1, op. cit., p. 394.
192. Coffel, Steve, "Photovoltaics: Electricity from Sunshine," Alternative Sources of Energy, March/April, 1980.
193. Clark, Cheryl, "Costs May Speed Solar Energy Use," Sacramento Bee, (Report on California Energy Commission Hearings of July 31, August 1, 1980.)
194. Monegon, Ltd., op. cit.
195. Figure 3.10-1, "A Typical Photovoltaic Device," Source: OTA, Application of Solar Technology to Today's Energy Needs, Vol. 1, op. cit., p. 396.
196. Figure 3.10-2, "Sample Reflecting or Refracting Concentrator Designs," Source: Monegon, Ltd., Vol. 1, op. cit., p. 59.
197. Clark, C., op. cit.
198. "T(exas) I(nstruments) on Schedule with PV Program," Solar Engineering, July, 1980.
199. "Photovoltaics for Federal Facilities," Solar Engineering, September, 1979.
200. "Markets for Navigational Aids, Remote Villages, and Even Banks," Solar Engineering, February, 1979.

FOOTNOTES (Continued)

201. Ibid.
202. Clark, C., op. cit.
203. Ibid.
204. OTA, Application of Solar Technology to Today's Energy Needs, Vol. 1, op. cit., p. 422.
205. Ibid., p. 423.
206. State of California, Solar Business Office, Using Solar Technology for California Agriculture, November, 1980, p. 89.
207. Ibid., p. 89.
208. Table 3.11-1, "Energy Efficiency Ratings," Source: Energy and Defense Project.
209. Office of Technology Assessment (OTA), Energy from Biological Processes, U.S. Government Printing Office, Washington, D.C., August, 1980, p. 3.
210. Bethel, James S., et. al., Energy From Wood, Unpublished report to the Office of Technology Assessment (OTA), Congress of the United States, Washington, D.C., January, 1979, p. 8.
211. U.S. Congress, OTA, Materials and Energy From Municipal Waste: Resource Recovery and Recycling From Municipal Solid and Beverage-Container Deposit Legislation, Vol. 1, July, 1979.
212. Figure 3.11-1, "Bioconversion Processes and Products," Source: Energy and Defense Project.
213. Schiefelbein, G.F., "Biomass Energy Systems Program, An Overview of Thermochemical Conversion Activities," from the Third Annual Biomass Energy Systems Conference Proceedings, DOE/SERI TP-33-285, Golden Co., October, 1979, p. 3111.
214. Goss, John and Richard Lang, Demonstration of a Pilot Plant Gas Producer Using Biomass Residues, California Energy Commission, Sacramento, Ca., July, 1980.
215. Figure 3.11-2, "Thermochemical Conversion Pathways for Fuels from Biomass," Source: Ann, Y.K., et al., "Research and Evaluation of Biomass Resources/Conversion/Utilization Systems," SERI/TP-33-285, op. cit., p. 467.
216. Seth, et. al., "The Potential for Biomass Lequefaction," SERI/TP-33-285, op. cit., pp. 131-451.

## FOOTNOTES (Continued)

217. Ushiba, et. al., "Catalytic Conversion of Biomass to Fuel," SERI/TP-33-285, op. cit., p. 451.
218. Benemann, J.R. and N.M. Weare, "Hydrogen Evolution by Nitrogen-Fixing *Anabaena Cylindrica* Cultures," Science, Vol. 184, No. 4133, April 12, 1974, pp. 174, 175. Also, Benemann, J.R. and J.C. Weissman, "Hydrogen Production by Nitrogen-Starved Culture of *Anabaena Cylindrica*," Applied Environmental Microbiology, Vol. 33, No. 1, January, 1977, pp. 123-131.
219. Kispert, R.G., et al., Fuel Gas Production From Solid Waste, Report No. 1258, Dynatech R/D Co., Cambridge, Ma., January 31, 1975.
220. Figure 3.11-3, "Methane Fermentation (Anaerobic Digestion) A Three Stage Process," Source: Smith, K.D., "Methane Systems: Principles and Practice," Energy Prime, (Revised, 1978), Dell Publishing Co., New York, pp. 196-207.
221. Table 3.11-2, "Fermentation Compared to Thermochemical Conversion," Source: Energy and Defense Project.
222. McCarty, P., et. al., Heat Treatment of Organics for Increasing Anaerobic Biodegradability, U.S. E.R.D.A. Grant No. ERDA-EYU-76-5-03-0326-DA-44, Stanford University, Stanford, Ca., June, 1977.
223. Hamburg, Bill, Dual Fuels, Inc., Motebello, Ca., personal communication and site visit to the pilot project constructed by Dual Fuels, Inc., and erected at the Municipal sewage treatment plant in Modesto, Ca.
224. Abeles, T.P., L. DeBaere, D. Ellsworth, and D. Freedman, Energy and Economic Assessment: Anaerobic Digesters and Biofuels for Rural Waste Management, Environmental Protection Agency, Contract #R-804-347-010, Rice Lake, Wi., June, 1978.
225. Baumann, Hazen, and Taignaides, "Sludge Digestion of Farm Animal Wastes," Compost Science, Vol. 4, (2), Summer, 1963, pp. 26-28.
226. Table 3.11-3, "Projected Maximum Alcohol Production from U.S. Biomass Resources," Source: U.S. Department of Energy, The Report of the Alcohol Fuels Policy Review, DOE/PE-0012, National Technical Information Service, Springfield, Va., June, 1979.
227. Table 3.11-4, "Biomass Feedstocks Immediately Available for Ethanol Fuel Production," Source: Ibid.
228. Table 3.11-5, "Biomass Feedstocks Potentially Available for Ethanol Fuel Production," Source: Ibid.



FOOTNOTES (Continued)

229. Figure 3.11-4, "Fuels from Biomass," Source: U.S. Department of Energy, Fuels from Biomass Program Summary, DOE/ET-0022/1, UC-61, Technical Information Center, Oakridge, Tn., January, 1978.
230. Table 3.11-6, "Biomass Conversion Processes," Source: Benemann, John R., Biofuels: A Survey, ER-746-SR, EPRI, Palo Alto, Ca., June, 1978, pp. 4-8.
231. State of California, Division of Oil and Gas, "Geothermal Hot Line," Vol. 9, No. 3, September, 1979, p. 10.
232. U.S. DOE, op. cit., p. 127.
233. Figure 3.12-1, "Representative U.S. Geothermal Projects," Source: Whitaker, Ralph, "Tapping the Main Stream of Geothermal Energy," EPRI Journal, Vol. V., No. 4, May, 1980, p. 9.
234. CEC, Commercial Status: op. cit., p. 117.
235. Rosen, L.C., and C.R. Molenkamp, An Environmental Overview of Geothermal Development, The Geysers—Calistoga KGRA, Vol. 2, Lawrence Livermore Laboratory, July, 1978.
236. CEC, Commercial Status, op. cit.
237. Figure 3.12-2, "Dry Steam Process Using Surface Condensers," Source: Ibid.
238. Figure 3.12-3, "Geothermal Dry Steam Cycle and Emissions Points," Source: Ibid.
239. Figure 3.12-4, "Two Stage, Flashed Steam Power Generation Process," Source: Ibid.
240. Figure 3.12-5, "Binary Power Generation Process," Source: Ibid.
241. Kruger, Paul, "Geothermal Energy," Annual Review of Energy, Annual Reviews, Inc., Palo Alto, Ca., 1976, p. 159.
242. State of California, Division of Oil and Gas, "Geothermal Hot Line," Vol. 10, No. 1, January, 1980, p. 4.
243. U.S. DOE, op. cit., p. 153.
244. Ibid, p. 143.
245. CEC, Commercial Status, op. cit.

## FOOTNOTES (Continued)

246. Geothermal Resources Council, Direct Utilization of Geothermal Energy: A Technical Handbook, Report No. 7, 1979.
247. Table 3.12-1, "Temperatures Required for Commercial, Industrial, and Agricultural Process Heat from Geothermal Source," Source: Renewables and Alternative Technologies Synopsis, Staff Draft, (CEC), Sacramento, Ca., September, 1980.
248. Ibid., p. 13.
249. Table 3.12-2, "Worldwide Direct Use of Geothermal Energy," Source: Ibid.
250. Ibid., p. 14.
251. Ibid., p. 14.
252. Blackwell, Charles A., Neil Book, and E. Hunter Herron, A Geothermal Direct Use, Economic and Engineering Study, Vol. 1, Department of Energy, August, 1979.
253. Ibid., p. 32.
254. Figure 3.13-1, "Mod-2 Wind Turbine Configuration, Diameter: 91m, Rated Power: 2.5MW," Source: Boeing Engineering and Construction Company.
255. Figure 3.13-2, "Poseidon L-180 Type Design, Diameter: 180m, Rated Power: 20MW," Source: Ljungstrom, Dr. Olle, "New Concepts in Vertical Axis Wind Turbines and Applications to Large Multi-MW Sizes Off-Shore Wind Turbine Systems," AIAA/SERI Wind Energy Conference Proceedings, AIAA Paper No. 80-0620, Boulder, Co., April 9-11, 1980.
256. Figure 3.13-3, "Cost of Wind Generators," Source: Arthur D. Little, Inc., Large Wind Turbine Generator Performance Assessment, Technology Status Report No. 1, EPRI AP-1317, Project 1348-1, January, 1980.
257. Ibid.
258. Putoff, R.L., et. al., "Installation and Checkout of the DOE/NASA Mod-1 2000 KW Wind Turbine Generator," AIAA/SERI Wind-Energy Conference Proceedings, AIAA Paper No. 80-0638.
259. Table 3.13-1, "Specifications of SWECS Under Development by DOE/Rocky Flats," Source: Rockwell International.
260. Figure 3.13-4, "Advanced SWECS Under Development (1-2 kw and 8 kw)," Source: Rockwell International.

FOOTNOTES (Continued)

261. Figure 3.13-5, "Annual Average Wide Power (Watts/M<sup>2</sup>) at 50M," Source: Battelle Pacific Northwest Laboratories.
262. Figure 3.13-6, "Annual Energy Output," Source: NASA Lewis Research Center.
262. Little, op. cit.
264. Habron, B.R., et. al., "Wind-Turbine Power Improvement with Modern Airfoil Sections and Multiple-Seed Generators," AIAA Paper No. 80-863.
265. Andersen, T.S., and H.S. Kirschbaum, "Multi-Speed Electrical Generator Application to Wind Turbines," AIAA/SERI Wind Energy Conference Proceedings, AIAA Paper No. 80-635.
266. Thomas, R.L., And R.M. Donovan, "Comments on Low-Cost Megawatt Size Wind Turbines," Large Wind Turbine Design Characteristics and R & D Conference, NASA Conference Publication 2106, DOE Conference Publication CONF-7904111, Cleveland, Oh., April 24-26, 1979.
267. Ginosar, M., A Large-Scale Wind Energy Program for the State of California, Doctoral Dissertation, Department of Environmental Science and Engineering, UCLA, 1979.
268. Lindley, C. and W. Melton, "Electric Utility Application of Wind Energy Conversion Systems on the Island of Oahu," Aerospace Corporation Contract E(49-18)-2439, Publication ATR-78-(7598)-1/UC-60, February 23, 1979.
269. Wegley, H., et. al., "A Siting Handbook for Small Wind Energy Conversion Systems," Publication PNL-2521 Rev. 1/UC-60, Battelle Pacific Northwest Laboratory, March, 1980.
270. Kornreich, T., "Environmental Issues Assessment," Proceedings of the Workshop on Economic and Operational Requirements and Status of Large Scale Wind System, Monterey, Ca., March 28-30, 1979.
271. Ibid.
272. Ibid.
273. Johanson, E.E., et. al., "Markets for Wind Energy Systems, When Where and What Price," AIAA/SERI Wind Energy Conference Proceedings, AIAA Paper No. 80-0613.
274. Table 3.13-2, "80MW Wind Farm Land Area Requirement and Number of Units," Source: Energy and Defense Project.
275. Table 3.13-3, "Number of Plants Required to Satisfy U.S. Electrical Demand," Source: Energy and Defense Project.

FOOTNOTES (Continued)

276. Table 3.13-4, "Wind Systems as Potential Targets," Source: Energy and Defense Project.
277. Little, Arthur D., Inc. "Distributed Energy Systems: A Review of Related Technologies," Department of Energy Contract No. EX-76-C-01-3871, DOE PEO3871-01/UC-60, November, 1979.
278. Manasse, F.K., "An Integrated Approach to Energy Supply for Small Communities," AIAA/SERI Wind Energy Conference Proceedings, AIAA Paper No. 80-0651.
279. Spaulding, A.P., "Wind Energy Systems MPI-200 Kilowatt Wind Turbine Generator," from NASA Conference Proceedings on Large Wind Turbine Design and R & D, op. cit.
280. Ibid.
281. Anonymous, "R & D on Salinity and Wave Power Urged," Chemical and Engineering News, June 14, 1976, pp. 28-29.
282. Congressional Research Service, Science Policy Research Division, Energy from the Ocean, Library of Congress, April, 1978, p. 83.
283. Leishman, J.M. and G. Scobie, "The Development of Wave Power," Report No. EAU M25, Ibid., p. 103.
284. Figure 3.14-1, "Scripps Wave Generator," Source: Energy and Defense Project.
285. Department of Energy, Ocean Energy Systems, A Program Summary, DOE/ET-0118, Government Printing Office, Washington, D.C., 1979, p. 198.
286. Ross, D., Energy from the Waves, Pergamon Press, Ltd., Oxford, England, 1979, pp. 85-97.
287. Ibid., pp. 71-84.
288. Figure 3.14-2, "The Cockerell Raft," Source: Energy and Defense Project.
289. Ross, op. cit., pp. 62-70.
290. Figure 3.14-3, "A Wave Energy System," Source: Leishman, J.M., and G. Scobie, op. cit.
291. Congressional Research Service, op. cit., pp. 106-109.

FOOTNOTES (Continued)

292. McCormick, Michael E., Salinity Gradients Tides and Waves as Energy, Conference Proceedings, "Energy from the Oceans Fact or Fantasy?" Report No. 76-1, UNC-SC-76-04, N. Carolina Coastal Plains Center for Marine Development Services, Raleigh, N.C., pp. 33-42.
293. Ross, op. cit., pp. 28-38.
294. Shelpuk, B., Director of the Wave Power Program of the Solar Energy Research Institute (SERI), personal communication.
295. Ibid.
296. Ibid.
297. Probert, K., and R. Mitchell, "Wave Energy and the Environment," New Scientist, August 2, 1978, pp. 37-373.
298. Battelle Memorial Institute, Energy Production, U.S. Department of Energy Contract EY-76-(06-1803), February, 1980.
299. Table 3.15-1, "An Estimate of the Cost Incentives Used to Stimulate Energy Production (In Billions of 1978 Dollars)," Source: Ibid.
300. Brady, J., and B. Zimble, "Conservation, Not Synfuels, Will Cut Imports," Energy User News, August 18, 1980, p. 22.
301. Table 3.15-2, "Energy Supply and Demand in the Year 2050," Source: Nadis, Steven, J., "An Optimal Solar Strategy," Environment, Vol. 21, No. 9, November, 1979.
302. Table 3.15-3, "A Proposed Long Term Solar Energy Economy," Source: Ibid.
303. Ibid.

SECTION 4

DISPERSED ENERGY SOURCES AND COMMUNITY SURVIVAL



## DISPERSED ENERGY SOURCES AND COMMUNITY SURVIVAL

### Introduction and Overview (4.1)

Reduction of national vulnerability through short and long range programs to encourage the utilization of dispersed and renewable sources of energy has not been traditionally considered an element of emergency and civil defense planning. However, as prior sections of this study note, decentralized energy and resource options are by their very nature less vulnerable to system disruption. Therefore, they constitute prime targets for contingency planning. With the additional advantage of renewable fuel capability, decentralized energy sources offer long range strategic advantages, including the reduction of dependence on imported resources and fuels.

Reduction of fuel dependence and improvement of energy system integrity are both elements of strategic counter-war planning. The pressures toward war frequently are related to critical dependence on and competition for scarce fuels; therefore, reduction in this dependence helps to reduce the likelihood of war.

Past civil defense programs have emphasized potential measures to reduce casualties, preserve essential resources (food, water, energy, etc.) and minimize industrial and economic damage. However, the major thrust of all past programs has been to (a) minimize fatalities and industrial damage in areas affected by nuclear attack, and (b) to relocate large numbers of people from potential target areas. Given the current budgetary constraints (\$100+ million per year for all programs), it is very difficult to adequately plan for major contingencies such as continued supplies of food, water and energy for centralized systems.

As a result of U.S. inattention to civil defense activities on a large scale, the vulnerability of the U.S. to nuclear crisis and nuclear war has increased substantially. The minimally funded programs for crisis relocation, if California is an example (and, in theory, this state is said to be far ahead of others), are only just beginning to take into account critical resource planning (food, water and energy) that must necessarily accompany population evacuation. At present, the Federal Emergency Management Agency (FEMA) is empowered to deal with a wide variety of emergencies, crises and civil defense activities. Preliminary research efforts indicate that contingency planning can be integrated, so that resource plans for a number of crises and emergencies can be effectively merged to reduce vulnerability.

From the standpoint of civil defense planning considered in isolation, a considerable number of U.S. experts have concluded that years of inattention to population protection (shelters, etc.) has resulted in a serious U.S. strategic problem. In congressional testimony, Dr. Samuel Huntington, Director of Harvard University's Center for International Affairs, stated:

By their words and actions, the Soviets have shown that they believe civil defense to be a critical element in deterrence. Given their belief, whether warranted or not, in the efficacy of civil defense, they can only perceive the United States as being weaker for absence of such a program. Given the importance they attach to damage limitation as a necessary element in a deterrent posture, they cannot assign a high level of credibility to a deterrent policy which does not attempt to limit damage to U.S. society if that policy had to be implemented. A substantial asymmetry in survivability between Soviet and American societies in the event of nuclear war can only encourage the Soviets to question the seriousness of U.S. purpose and hence also encourage them to follow a more adventurous policy.

...In the event of a confrontation with the Soviet Union in which American society was considerably more vulnerable than Soviet society, the credibility of the U.S. nuclear deterrent with respect to Soviet military and diplomatic pressure on Western Europe military and diplomatic pressure on Western Europe would be greatly reduced in the eyes of both the Soviets and the Western Europeans. This does not imply that this U.S. disadvantage would lead the Soviets to risk lightly nuclear war...(However,) in an age of strategic parity, the greater the vulnerability of American society, the less the credibility of the U.S. strategic forces as a deterrent to Soviet military action in Europe or elsewhere.<sup>1</sup>

There is considerable controversy over the efficacy of civil defense programs, to "save" a substantial number of people in the event of nuclear war. Obviously, in an all-out exchange such as that described in Section 1 of this report, in which 20 million to 160 million Americans would be killed immediately, even the best-funded CD programs would be hard-pressed to offer much in the way of survival options. Residual radioactivity alone would render most of North America uninhabitable and deaths on an unprecedented scale would follow for generations.

However, in the case of a more limited exchange of weaponry or isolated terrorist events using nuclear weapons or even conventional bombs which could create serious disruptions to centralized energy, food, and resource supply systems, massive shortages causing injuries and deaths could be minimized, if not eliminated, by properly planned CD programs incorporating effective energy and resource contingency planning.

It is somewhat surprising that local, decentralist approaches to population vulnerability and defense planning have not been taken as seriously as decentralist approaches to the protection of nuclear weapons systems. A key strategic objective in weapons system planning is the protection of large numbers of weapons (carried by submarines, bombers and missiles) for retaliatory reasons. Dispersal of

nuclear weapons to prevent destruction by enemy targeting of weapons in centralized locations has historically been a key factor in military planning. The newest nuclear missile system, the MX, planned for use by the U.S. in the 1980s, is designed to be housed in multiple and movable shelters in order to disperse potential targets and reduce "first strike" destruction. This concept is based on the ability to hide any one of the proposed 200 missiles in one of 23 shelters. This forces enemy targeting of all 4,600 missile shelters in the MX system to assure destruction of all the missiles during an attack. Taking the decentralist approach to nuclear weapons protection another step, defense consultant Richard Garwin has proposed a water based submarine version of the MX system. This proposal would involve the building of a fleet of mini-submarines (called SUM - Shallow Underwater Submarines), each capable of carrying two MX missiles. According to his analysis, the planned land-based MX system is too centralized, and a 1980s fleet of 77 submarines would be more decentralized, less expensive, and could "protect" the weapons equally as well.\*<sup>2</sup>

There has been little attention to similar issues of dispersal and decentralization in planning for population survival, especially in areas of resource contingency planning. Prior U.S. research has concentrated on the protection of weapons, military installations, major target areas and the like.

In a strategic sense, the population dispersal issue has been raised by physicist Theodore Taylor, who would use modern technology to disperse and decentralize major cities, "so that there aren't targets like Tokyo and London and Leningrad any more."<sup>3</sup> On this point, Nigel Calder, author of a recent analysis of nuclear war prospects, counters:

The snag is that to target villages is just a matter of subdividing the payloads of missiles into more and more independently targetable warheads, or else relying upon radioactive fallout to kill people over huge areas. A village and even a city would be safer from attack or threat of attack if it were not part of a nation-state itself may disappear in the nuclear age. It could conceivably give way to a world empire run by one power with a monopoly on nuclear weapons, or a global police state engineered by frightened consensus, or a benign and nonbureaucratic world government ministering to Taylor's "globe of villages."<sup>4</sup>

---

\*It is interesting to note that both in the case of the land-based MX system, and Garwin's SUM substitute, alternative energy sources such as fuel cells (for the submarines) and solar energy (for the land MX) are proposed for energy sources. Although civilian planners may not be overly concerned with the development of alternate, renewable energies, the military has taken this into account.

However valid Calder's points may be on the overall impacts of such a massive population dispersal, he fails to address the salient points of decentralization as a strategic energy/vulnerability option. In Sections 1, 2, and 3, the overwhelming vulnerability of the U.S. to serious resource shortages is addressed. Such vulnerability exists whether or not nuclear war occurs. Enhancing the overall security of the U.S. by decentralizing and dispersing energy resources to better serve local populations may well serve as a primary deterrent to nuclear war. Policies of conservation, dispersion and accelerated reliance on renewable, local and more efficient fuel and power options would accomplish the following:

- Reduce reliance on imported fuels, thereby decreasing chances of international war (over scarce fuels)
- Reduce reliance on strategic materials, through reduction in imports and lessened demand, thereby decreasing chances of international war (over scarce materials)
- Reduce vulnerability and dependence on centralized energy and resource systems, thereby reducing likelihood of attack (or sabotage) on central systems
- Reduce dependence on centralized systems, thereby increasing local self-sufficiency, thereby protecting population in case of crisis, disruption or attack
- Increase reliability of local energy and resource systems, thereby insuring a more rapid and higher rate of community recovery from disruption in central systems

## Community Survival and Recovery: Background (4.2)

In the 1960s and the 1970s, a number of studies were completed for U.S. civil defense agencies on supplying emergency power to communities affected by centralized power disruptions. In the field of electrical power and natural gas, the key studies were performed for the Office of Civil Defense by URS corporation.<sup>5,6,7</sup>

The studies addressed the problem of emergency power requirements ranging from needs for public shelters, energy facilities, public services, industrial facilities and other key needs. Damage from a nuclear attack would result in serious failures of electric equipment, including the effects of electromagnetic pulse (EMP), and destruction of facilities and grids. Three scenarios indicating the need for emergency power are summarized below:

### EXAMPLE 1: Providing Ventilation for a Large Shelter

A shelter occupied by 5,000 persons receives minimal blast damage but moderate fallout. Shortly after the attack, commercial power is not available. Battery-powered lighting is immediately activated and, since the shelter is at full capacity, standby manual ventilation equipment is put into immediate operation. After several hours the battery-operated lighting units begin to fail and the effective temperature in the shelter rises dangerously close to 85°, despite the utilization of all available means of ventilation. The shelter manager is now faced with the possibility of evacuating some or all of the occupants through an unsafe (e.g., radioactive) environment or staying and risking serious overheating problems. If this shelter had been provided with an engine generator set (or its equivalent) sufficient in size to maintain a ventilation rate of 15 cfm per person and a lighting level of 5 foot candles (a 75-kw generator would suffice), the problem would not have arisen.

### EXAMPLE 2: Emergency Power for Shutdown Operations

The superintendent of an oil refinery (100,000 barrel/day capacity), recognizing the value of a rapid shutdown procedure in the event of natural or nuclear disaster, had made necessary plans for such a shutdown. Since the power-generating station was nearby and the refinery was served by three separate incoming services, power failures had never been a problem. Therefore, he decided to rely upon commercial power for the shutdown procedure. However, the attack came with little notice and, while not affecting the immediate locale, did temporarily disrupt the regional power grid, resulting in loss of power to the refinery for several hours. As a result, control systems were inoperable (although air-activated controls operated until pressure dropped), the steam supply (essential



to the shutdown operation) was rapidly used up, and cooling water pumps stopped. Serious thermal damage occurred in several of the large units, products solidified in pipelines, and one isolated unit caught fire and burned. Still, the plant superintendent considered himself very fortunate that explosions and fires did not occur through the plant. If sufficient emergency power (approximately 4,800 kw), had been provided to run essential controls, boilers, and cooling pumps, damage would have been minimal instead of extensive.

### EXAMPLE 3: Maintaining Production Quotas

Some weeks after the attack, when recovery operations had begun, the superintendent of a "hot" mill was asked to begin the production of can stock for the upcoming canning season. Since the facility was undamaged and raw materials were available, production seemed assured. However, as production resumed, it was found that the availability of commercial power presented a major constraint. Because the commercial power system was still being repaired and demands were numerous, the system was overloaded, with consequent frequent outages. It finally became necessary to enforce quotas for consumers. The result in the mill was that the production of can stock was sharply reduced and, concomitantly, the reject rate soared, due primarily to instability in the hot processes. To increase the amount of power available and to improve the reliability, the plant adopted the concept of providing supplementary power by "underdriving" a portion of its large motors. This required connecting diesel prime movers, with appropriate controls, to eight of the large motors in the plant. These prime movers were then routinely run to provide approximately 15 percent of the total operational load. Further, they were so connected that when power outages occurred they could serve as emergency generators to maintain control over the hot processes. Under this system, production approached anticipated levels and the reject rate declined sharply.<sup>8</sup>

The studies found that major needs for emergency power would come from shelters, mass-care centers, utilities and industry. In the event of failure of conventional systems emergency power sources would be engine generator sets, industrial generators (isolated from main grids), and unconventional sources. Such unconventional sources would include synchronous motors (found in industry) which could be "reversed" to provide emergency generators (locomotive and ships). Specific studies were done on the feasibility of converting induction motors to run backwards as induction generators.\*

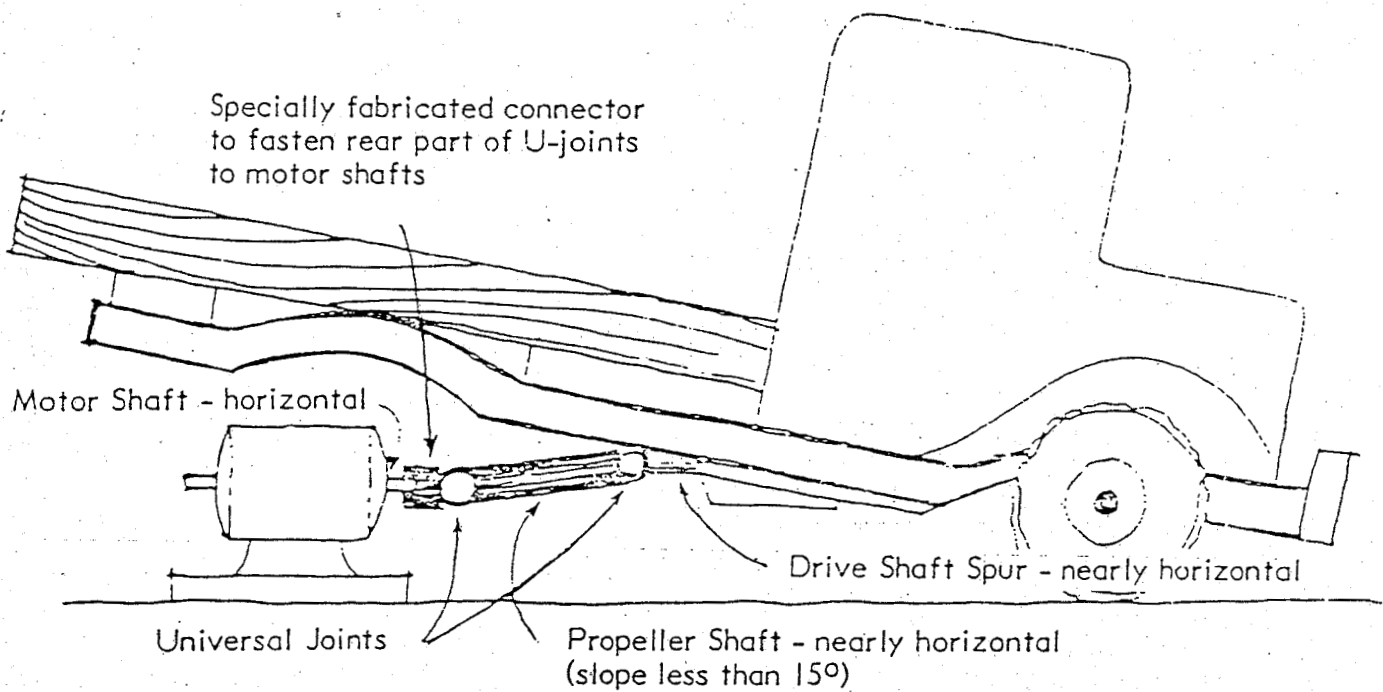
\*The basic principle of the induction generator is easily understood when one considers that the energy flow in induction machines is a reversible



The URS study on induction motors found that 10-150 horsepower motors are common in many industries and commercial facilities. Components to construct induction generators are commercially available; they include induction motors, power capacitors, motor controllers, engines, equipment to connect drive shafts of engines to motor shafts, and fuel and coolant sources. Figure 4.2-1 and 4.2-2 illustrate the connection of a truck engine to an induction motor for induction generation, and a schematic of the load connection.

Figure 4.2-1<sup>10</sup>

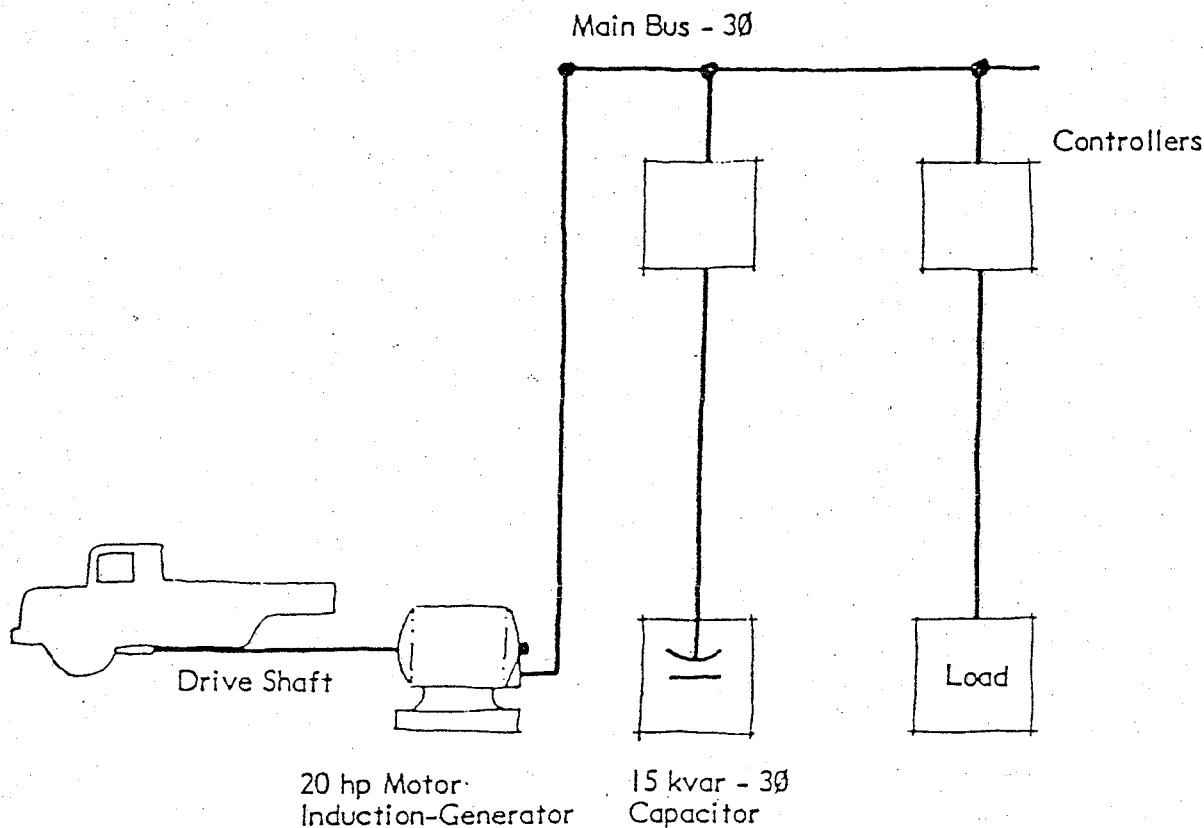
CONVERSION OF TRUCK ENGINE TO INDUCTION MOTOR



process. An induction motor energized from a power source develops mechanical power by running at a speed slightly less than its synchronous speed. Conversely, an induction motor driven in the same direction at a speed slightly greater than its synchronous speed will deliver electrical power when connected to a power system. If the machine is driven above synchronism by the same rpm that the machine normally operates below synchronism, the generator will deliver approximately rated current at rated voltage and rated efficiency, and the electric power output will be approximately equal to the rated shaft motor power. However, the generator power factor will be much lower than when operated as a motor.<sup>9</sup>

Figure 4.2-2<sup>11</sup>

SCHEMATIC OF LOAD CONNECTIONS



The URS study found that improvised induction generators can develop useful electric power to fill a wide variety of needs during power shortages. Electric motors, heaters, fluorescent lamps, and other devices can be operated. The safety of the systems and other considerations were addressed, as well as connecting these dispersed systems into local grids. The study developed a manual and training program which should be a valuable addition to emergency and civil defense programs. The conclusions were as follows:

The skills of competent craftsmen are required at some stage of assembling or using an improvised source of electric power. The skills required for improvising an induction generator are an electrician, a welder, and a mechanic. Pre-disaster planning and an exercise can substantially reduce these skill requirements during an emergency.

It is important to define electric power requirements specific to each facility, especially with regard to rapidity of response (how fast must power be restored), reliability (cost of an unscheduled shut-down), maximum load, and degree of power regulation. If these requirements are very stringent, then an improvised power plant—either an induction generator or a

rental engine generator set—is very likely unsuitable. A stand-by power plant that is permanently installed and with a transfer switch will be necessary to meet stringent requirements. It must also be tested regularly to maintain operability.

An induction generator is the preferred source of improvised electric power when:

- All of the major or expensive parts are available
- Time and resources can be made available to set up and test it
- Equipment to be served can function adequately with the power developed by the machine
- An interval without power, while assembling the induction generators, is acceptable
- Renting or leasing an engine generator set is either unattractive or impractical
- Maintaining engine generator sets is either too expensive or impractical

Despite the practicality and convenience of using induction motors as induction generators, the idea probably would not occur to most of those who could benefit from it either during pre-disaster planning or during a prolonged power outage.<sup>12</sup>

### Electromagnetic Pulse Protection

One of the key issues in planning for protection of electrical facilities and grids in the event of nuclear attack is EMP (electromagnetic pulse) effects. High altitude detonations of nuclear weapons create EMP, an electromagnetic burst of extremely short duration (a fraction of a second). Similar to lightning, EMP exhibits a rise in voltage a hundred times as fast; thus, conventional equipment designed to protect electric equipment against lightning cannot be effective against EMP, because it works too slowly. High altitude nuclear bursts produce extremely high EMP, which can affect communications and electrical systems for thousands of miles. When the U.S. tested a hydrogen bomb in space above Johnson Island in the Pacific in 1962, EMP caused havoc in Honolulu, resulting in failure of streetlights and various electronic circuits (including burglar alarms).<sup>13</sup>

Many of the components of modern communications, electronics and power technology are highly vulnerable to EMP. For this reason, military B-52 bombers\* use antiquated vacuum tube components, rather than more modern but more vulnerable transistors, since they are expected to serve in a "nuclear environment."

\*The Pentagon has recently decided to combine fuel cell technology with MX missile EMP protection. In order to reduce EMP damage to missiles in the MX system, fuel cells will be used, rather than back-up engine generator sets, to power the missile launch centers. By using the fuel cells, each missile facility will be isolated from EMP effects on electric lines and related equipment; the fuel cell provides a "chemical fluid interface."<sup>14</sup>

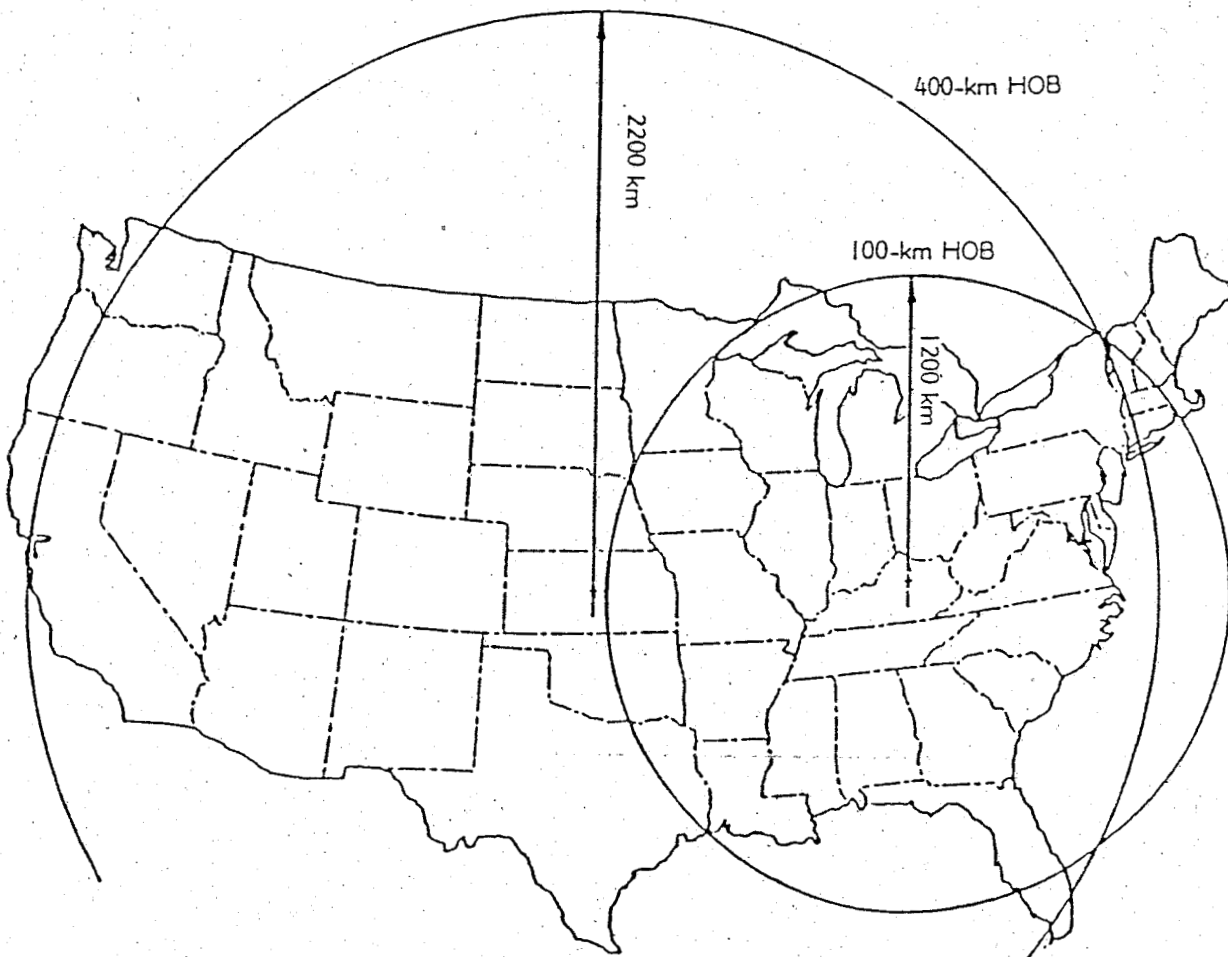
EMP can cause actual physical damage to electrical system components, as well as create instabilities in grids which cause systematic failures. Disturbances in electric systems may be categorized in these six major areas:

1. Faults on overhead lines: Voltages induced on overhead lines can cause numerous faults in distribution, including substations.
2. Lock out of reclosers and reclosing circuit breakers: These protection systems on distribution lines can interpret EMP as "permanent faults" and lock out the system, resulting in sudden load loss.
3. Destruction and malfunction of relays: Solid state electronic relays in electric systems can fail in "unsafe mode," causing the line to trip out.
4. Generator trip out: Generators can be tripped out in two ways. First, EMP may induce voltages and currents in generator control circuits causing generator trip out. Second, disturbances in the power system can cause trip out by creating overspeed/underspeed in the generator.
5. Monitor and control interference: Damage to monitor/control circuits by EMP can be direct, or can cause transmission tie lines to be severed by EMP-induced power flows.
6. Damage to computer control and dispatch centers: Computer memory can be erased by EMP; therefore, central computer centers for dispatching and load control can malfunction, causing loss of system control.<sup>15</sup>

The map of the U.S. shown in Figure 4.2-3 shows the vast extent of possible EMP damage from a 400 kilometer (248 mile) air burst, and a 100 kilometer (62 mile) air burst. As a recent Department of Energy study noted, the EMP "covers a large percentage of the nation's power system at essentially the same instant, rather than a single line or substation."<sup>16</sup>

Figure 4.2-317

AREA OF COVERAGE OF EMP FROM HIGH ALTITUDE DETONATIONS



According to the Department of Energy study:

Many power system components will not be damaged unless they are relatively close to a target (within four to twenty-two miles). Apparently no quantitative analysis has been made to use these data with an assumed list of targets

and weapon yields to determine the percentages of power components that would be damaged. Depending upon the number of weapons, it is conceivable that a sizable portion of the nation's power system would escape damage from the blast, unless targeted, but would be subjected to damage by EMP.

One could envision the possibility that the combined effects of faults caused by lines broken or knocked down by blast effects and faults induced by EMP could lead to a nationwide blackout. Little can be done to alleviate the effects of the blast. However, the combined effect of moving some of the vulnerable equipment off-line (thus reducing the number of EMP-induced faults) and placing the power system into a more secure state could avoid a nationwide blackout.<sup>18</sup>

Because of the unique damage which would be imparted to highly sophisticated centralized utility systems by nuclear weapons effects (especially EMP), the DOE report suggests a policy which may be likened to emergency dispersion and decentralization:

Depending upon whether the nation's power system remains in synchronism or not, the post-attack recovery could be from one of two states. The worst case would be from a completely shut down system. In this case, one would be recovering from a nation-wide blackout similar to the 1965 Northeast blackout and the 1977 New York blackout with the following complications:

1. Lack of help from neighboring utilities who are busy experiencing the same problems.
2. Loss of some system facilities, permanently damaged by heat and overpressure.
3. Poor communications due to possible damage to the telephone system.
4. Impending threat of radioactive fallout.

The best state from which to recover would be one in which the generation had remained in synchronism, in spite of faults caused by heat, overpressure and EMP-induced effects on vulnerable equipment that had not been isolated by the proposed switching operations. The generation would be operating at a relatively low percentage of its rating due to the pre-attack measures.

Attempting to keep the entire nation in synchronism during the combined effects of overpressure, heat and EMP may not be realistic. It may be more practical to sever tie lines between companies and even allow the systems of individual



companies to break into islands. Comparisons between these two divergent philosophies require very complex analysis. Utility personnel are generally in favor of maintaining synchronism, if at all possible. Maintaining synchronism seems to be something of an all or nothing philosophy.<sup>19</sup>

Many components of systems can be protected against weapons effects, including EMP, but drawbacks are primarily the added costs of such equipment. Protected measures and policies suggested in recent studies include:

- "Hardening" and burying key components and distribution lines
- Stockpile vulnerable parts, for replacements
- Employ "surge arresters" and specialized equipment to protect distribution/transmission systems
- Protect and harden vulnerable solid-state components
- Provide back-up communications systems
- Improve training and emergency shut-down procedures.<sup>20,21</sup>

The DOE study notes that other key problem areas involve protection of nuclear power plants which may experience "loss of reactor control due to EMP." A utility representative referred to in the study "suggested that they might consider shutting down their nuclear units upon notice of an attack. ...Officials of one large utility expressed doubts that it would be possible to bring one of their large units down from near rated load to auxiliary load level and stop there."<sup>22</sup>

Obviously, these effects affect small systems as well as large systems and many components of decentralized grids would be damaged by EMP and other weapons effects even if the components were located hundreds, and perhaps thousands of miles from air detonation.

A special interest in dispersed systems is the protection of complex control systems utilized in modern wind-electric generators, solar photovoltaic systems, and other modern alternative energy systems. Photovoltaic systems may be vulnerable to EMP, but no specialized studies have been conducted on this problem.\*

Early civil defense studies are significant precursors to a more comprehensive approach to community energy management and strategic dispersal. The early studies point out the following energy trends:

- Central systems may be disrupted by weapons effects to a greater degree than most general studies acknowledge.

\*Photovoltaic (DC) panels are voltage-protected by bypass diodes in one direction, and industry experts believe that EMP protection can be developed.<sup>23</sup>

- Protection can be provided to many components of central systems, but reliability cannot be guaranteed.
- Local energy approaches can be developed to greatly assist in emergency situations.
- Training programs and knowledge of local power sources, to be effective, must be developed in advance.
- Available power systems in communities can be tapped in times of emergency, if adequate training and stockpiles of key parts are available.

### Selection of Alternative Fuels and Electric Power Sources (4.3)

Increasing the energy self-sufficiency of communities and regions can be accomplished by integrating a combination of available dispersed and renewable energy technologies. The Energy and Defense Project has developed criteria for rating the available technologies\* (fuels and electricity). The two matrices following this introduction illustrate the properties of the major technologies discussed in Section 3.

Categories in the matrices are judged from a strategic perspective, based on criteria of available (local and regional), current and projected costs, and overall flexibility. The rank is from 10 (best) to 0 (worst). The categories are expressed primarily as Y (yes) or N (no, not applicable). Alternative categories are L (low), M (medium), H (high); in some cases, a range is expressed (L-H), or dual flexibility (Y/N).

---

\*Ranking of the various technologies discussed in the report was determined by research, and confirmation at the Project's September 1980 technical seminar.

FUELS MATRIX

Figure 4.3-124

DERIVED FUELS	Rank	Dispersed	Central	Renewable Feedstock	Feedstock Flexibility	Grid-Connected	Grid-Independent	Operation and Maintenance Costs	Local Feedstock	Site-Dependent	Regional Components	Local Maintenance	Capital Intensive	Short Lead Time	Mobility	Storage	End Use Flexibility	Scale	\$/Million BTUs
	Gasoline <sup>1</sup>	3	N	Y	L	H	Y	N	H	L/H	Y	N	Y	N	N	H	H	L	L
Diesel <sup>2</sup>	6	N	Y	L	H	Y	N	H	L/H	Y	N	Y	N	N	H	H	L	L	5.50 to 8.00
Crude Coal <sup>3</sup>	5	N	Y	L	M	Y	N	L/H	H	Y	Y/N	Y	Y/N	N	H	L	M/L	M/L	5.00 to 7.00
Crude Shale	9	Y	Y	L	M	Y	N	H	H	Y	Y/N	Y	N	N	H	L	M/L	M/L	5.00 to 8.00
Methanol <sup>4</sup>	8	Y	Y	M	H	Y	Y	M	H	N	N	Y	N	Y/N	H	H	S/L	S/L	6.00 to 8.00
Ethanol <sup>5</sup>	10	Y	Y	H	M	Y	Y	H	H	Y	Y	Y	Y	N	H	H	S	S	8.00 to 12.00
Low BTU Gas <sup>6</sup>	9	Y	N	H	H	Y	Y	M	L/H	Y	Y	N	Y	Y	L	M	S/M	S/M	4.00 to 5.00
Med BTU Gas <sup>7</sup>	9	Y	Y/N	H	H	Y	Y	H	L/H	N	Y	Y	Y	Y	L	M	S/L	S/L	4.50 to 5.50
Biogas <sup>8</sup>	7	Y	N	H	M	Y	Y	L	H	Y	Y	Y	Y	N	L	M	S	S	4.50 to 8.00
SNG <sup>9</sup>	7	N	Y	L	H	Y	N	M	L/H	N	N	Y	N	Y/N	M	M	L	L	5.50 to 8.50
Hydrogen <sup>10</sup>	1	Y	Y	H	H	Y	Y	H	L/H	Y	Y/N	Y	N	N	L	H	S/L	S/L	7.00 to 50.00
Biomass Oils <sup>11</sup> & Lubricants	6	Y	N	H	L	Y	L	H	H	Y	Y	N	Y	Y	H	H	S	S	8.00 to 12.00

## NOTES: FUELS MATRIX

### 1. Gasoline

Gasoline is a premium fuel which can be used in stationary or mobile applications. However, in current refining practices, lower quality heavy crude oil will not produce as much gasoline as lighter crudes (previously in greater abundance). It can be produced from methanol (via Mobil Oil Company process), however, allowing significant resource flexibility (bimoass, coal, natural gas, shale, heavy crudes, tar sands, etc.)

### 2. Diesel

Diesel oil is a middle distillate. This category (on the matrix) includes all middle distillates, from aviation fuel to kerosene. It is a more difficult fuel to produce from feedstocks other than crude oil, and is not as versatile a fuel, from a strategic standpoint.

### 3. Crude Oil

Crude oil is a natural oil (as is shale oil), and can be made from coal, tar sands, wood and other carbonaceous feedstocks. The lower rating (5) relates to coal production, and the higher rating (9) relates to production from new domestic oil resources. Shale oil is a more attractive feedstock than heavy crude oil.

### 4. Methanol

Methanol can be made from all hydrocarbon feedstocks through partial oxidation (gasification). This is an extremely versatile fuel, but catalysts are required to convert producer gas to methanol. This limits production flexibility, and reduces local production capabilities. To insure continuous production, an inventory of catalytic materials would be required.

### 5. Ethanol

Ethanol can be made from non-renewable resources, but is typically made from biomass-derived sugars and starches. This is an immediately available premium fuel, which can be used as an independent fuel or blended with other products such as gasoline. The conversion technology is commercially available with locally available components.

### 6. Low Btu Gas (LBG)

LBG is gas with a maximum heat value of 200 Btu/ft<sup>3</sup>, made from hydrocarbon feedstocks. It is made through partial combustion in an air-blown gasifier. This gas can be used in internal combustion engines, but cannot operate gas turbines (with current technology). It can substitute for most natural gas uses.

## 7. Medium Btu Gas (MBG)

MBG is a partially combusted hydrocarbon gas with a heat value of 200-500 Btu/ft<sup>3</sup>. It requires pure oxygen in the gasification process, which increases costs and requires additional equipment. This gas can be used as a feedstock for synthetic fuels (methanol, SNG, gasolines, etc.) and as a fuel in gas turbines and other heat engines (boiler, etc.).

## 8. Biogas

This is a methane-rich (CH<sub>4</sub>) gas with a heat value of 500-700 Btu/ft<sup>3</sup>, and can be used as a boiler fuel in gas turbines and other heat engines. It is a substitute for natural gas. It is typically produced by decomposing organic material which are locally available.

## 9. Synthetic Natural Gas (SNG)

SNG is a high-heat value gas (1,000 Btu/ft<sup>3</sup>), which is a direct substitute for natural gas in essentially all applications. It is made through catalytic conversion of MBG. Feedstocks include oil, coal, shale oil and biomass. SNG can also be made by purifying biogas.

## 10. Hydrogen (H<sub>2</sub>)

Hydrogen can be extracted from coal via gasification processes, or it can be made by the electrolytic decomposition of water. It is a volatile, high quality fuel which can substitute for natural gas. However, conversion processes are highly energy-intensive, and significant infrastructure problems stand in the way of widespread utilization (storage, distribution, etc.).

## 11. Biomass Oils and Lubricants

These are vegetable oils which can be derived from locally available oil-producing plants (sunflower, safflower, jojoba, etc.). These oils have been used successfully to substitute for diesel fuel, although their strategic significance stems more from their value as lubricants than fuels.



Figure 4.3-225

DISPERSED ELECTRICITY MATRIX

	Rank	Dispersed	Central	Renewable	Fuel Flexibility	Grid-Connected	Grid-Independent	Local Fuel Supply	Site-Limited	Local Components	Local Maintenance	Capital Intensive	Short Lead Time	Mobility	Operation and Maintenance Costs	Size Range (MW)	Intermittent	Cost (\$/kw) Capacity
Cogeneration <sup>1</sup>	10	Y	Y	Y/N	Y	E	Y/N	N	N	Y	N	Y	Y	L	0-50	Y/N	N	500-1500
250MW Small Fossil Plants <sup>2</sup>	10	Y	Y	Y	Y	E	N	N	N	Y	Y	Y/N	Y/N	H	0-250	N	N	500-2000
Small Hydro <sup>3</sup>	10	Y	N	Y	N	E	Y	Y	Y	Y	N	Y	N	L	0-30	Y/N	N	600-1000
Wind <sup>4</sup>	7	Y	Y	Y	N	D	Y	Y	Y	Y	Y	Y	Y	L	0-5	Y	Y	1000-2000
Photovoltaics <sup>5</sup>	4	Y	Y	Y	N	D	Y	N	N	Y	Y	Y	Y	L	0-10	Y	Y	10,000+
Biomass Steam <sup>6</sup>	8	Y	Y	Y	Y	E	Y	Y/N	Y/N	Y	Y	Y	Y/N	M	2-50	Y/N	N	500-1500
Biomass Low BTU Gas <sup>7</sup>	7	Y	Y	Y	Y/N	E	Y	Y/N	Y/N	Y	N	Y	Y	M	0-5	Y/N	N	500-1200
Geothermal <sup>8</sup>	10-6	N	Y	N	N	D	Y	Y	Y	Y	Y	N	N	H	5-50	N	N	700-4000
Fuel Cell <sup>9</sup>	3	Y	Y	Y/N	Y	E	Y/N	N	N	N	Y	N	Y	H	0-5	N	N	5000+
Waves <sup>10</sup>	1	N	Y	Y	N	D	Y	Y	N	Y	Y	N	Y	H	?	Y	Y	15,000+
OTEC <sup>11</sup>	1	Y	Y	Y	N	E	Y	Y	N	Y	Y	N	N	H	?	N	N	15,000+
Low Temp Solar Thermal <sup>12</sup>	5	Y	Y	Y	N	E	Y	N	N	N	Y	N	Y/N	L	0-5	N	N	4000+
High Temp Solar Thermal <sup>13</sup>	4	Y	Y	Y	N	E	Y	N	N	N	Y	N	Y/N	M	0-10	Y	Y	6000+
Fossil Gasification <sup>14</sup>	10	Y	Y	N	Y	E	N	N	N	Y	Y	Y	Y	M	5-50	N	N	1500-4000

## NOTES: DISPERSED ELECTRICITY MATRIX

### 1. Cogeneration

Cogeneration is the generation of electrical or mechanical power and the production of useful heat from the same primary source of fuel. A typical configuration is the use of steam from a fossil-fired boiler to drive a turbine-generator, and the subsequent use of the exhaust steam for space or water heating.

### 2. Small Fossil Plants

Small fossil plants are defined as any fossil-fired electric generating plant with an output capacity of less than 250 megawatts. These are primarily steam-driven turbine-generators.

### 3. Small Hydro

Small hydro is an electrical generating system with an output capacity of less than 30 megawatts powered by falling or moving water. This source may represent the most thoroughly developed technology included in this discussion; plants of virtually any size are readily available from commercial vendors.

### 4. Wind

Any one of numerous Wind Energy Conversion Systems (WECS) use wind-powered propellers or blades to drive an electric generator. Small systems are commercially available at this time; however, systems in the megawatt range are still in the development and testing state. The size range given here is for individual towers, much larger outputs might be obtained from wind "farms" of 25 or more units.

### 5. Photovoltaics

Photovoltaic power involves the direct transformation of sunlight into electricity through the excitation of various semiconductor materials. Very small systems are currently in use, but the high cost of high-grade photovoltaic materials currently limits an otherwise wide range of applications.

### 6. Biomass Steam

Biomass steam is any plant material or waste from plant material that is combusted in a boiler. Such a system may use a Rankine-cycle heat generator to produce electricity or a conventional turbine-generator with fossil-fuel backup.

### 7. Biomass Low Btu Gas

Biomass Low Btu gas is produced by partially combusting biomass fuel in a reactor to break the fuel down into its hydrogen and carbon-monoxide components. These two combustible gases may then be burned in boilers or certain combustion engines.

## 8. Geothermal

Geothermal-electric power may be produced by utilizing the heat within the earth resulting from either tectonic activity or radioactive decay. The most developed technology uses naturally created steam. These systems, however, are limited by relatively few sites and problems associated with the chemistry of geothermal steam. The U.S. enjoys extensive "hot dry rock" resources—requiring the injection of water to produce steam—but the required technology is still in the early stages of development.

## 9. Fuel Cells

A fuel cell is an electrochemical device which chemically combines hydrogen and oxygen to produce electricity and water. The system has been utilized in specialized applications such as space vehicles but large-scale applications are in the early development stages.

## 10. Waves

The energy of waves may be converted into electricity by the use of wave pumps, pneumatic devices, motion devices, underwater pressure field devices, and facilities powered by the mass transport of water from breaking waves. Very small systems are currently being developed; however, technological obstacles have inhibited full-scale development of this source.

## 11. Ocean Thermal Energy Conversion (OTEC)

OTEC produces power from the thermal layer differences between warm surface water and colder deep ocean water. Serious engineering obstacles and a limited number of sites have inhibited development of this source.

## 12. Low Temperature Solar Thermal

The most common low temperature solar technology is the solar pond which uses salinity layers in a body of water to absorb and trap solar energy and convert that heat into electricity through a Rankine-cycle turbine. The technology is in commercial use in several countries and in the testing stage in the U.S.

## 13. High Temperature Solar Thermal

High temperature solar thermal systems use concentrating collectors to focus solar energy on a target. The sunlight can be concentrated sufficiently to produce temperatures up to 2,000°F (1,093.3°C). Water in the receiver is thus boiled to produce steam for turbine-generators. Very small high temperature systems are commercially available but larger systems are in the testing and development stages.

## 14. Fossil Gasification

This system uses an oxygen-blown gasifier to convert fossil fuels such as coal or heavy oil into their carbon monoxide and hydrogen components which are subsequently used in a combustion system to generate electricity.

## NOTES: CHARACTERISTICS OF DISPERSED FUELS AND ELECTRIC POWER TECHNOLOGIES

### 1. Rank

Rank is evaluation on a scale of 1-10, with 10 having the highest value, judged from a strategic perspective. In fuels, high ranks designate the suitability of a fuel from a local and regional production and use basis. Flexibility, renewability, ease in production, and other key characteristics affect the ranking. In electricity, the same strategic evaluation applies, with some technologies which are inherently dispersed and commercially available, having high rank (cogeneration, small fossil plants, etc.). Technologies such as photovoltaics and wind power are renewable and available, but are ranked lower because of current low production and high costs; however, from a community/regional perspective, these are important technologies to integrate in emergency and energy planning.

### 2. Dispersed

This describes the local and regional production possibilities for fuels and electric power. For example, gasoline, diesel fuel, crude oil and synthetic natural gas are all fuels that require considerable capital investment in high technology production facilities and are most economically made in large bulk quantities (i.e., production runs greater than 3,000 tons or 2.7 million kilograms per day). These fuels are therefore best produced in large centralized facilities (i.e., not dispersed) and require distribution networks to reach their ultimate consumers. Methanol, ethanol, biogas and the other fuels listed in the fuels matrix are more easily produced and are thus evaluated as being good potential candidates for dispersed or decentralized supply systems. It is also economical to produce them in smaller lot quantities (i.e., less than 1,000 tons or .9 million kilograms per day). On the matrix, all of the technologies for electricity are capable of dispersion with the exception of geothermal and waves, which are site-specific.

### 3. Central

In addition to dispersed fuels (or systems) and electrical technologies, centralized technologies may also apply to many of the same categories. For example, cogeneration systems may occur in central as well as dispersed locations; methanol and ethanol fuels can be either dispersed or centralized.

### 4. Renewable (Renewable Feedstocks)

In fuels and electricity, renewable characteristics refer to solar, biomass, wind, water and other renewable technologies. All of the fuels listed can be made from bio-feedstocks, so they are rated as low, medium or high potential for commercial production. Electrical technologies are characterized on a simple yes/no basis.

## 5. Feedstock/Fuel Flexibility

In fuels, high flexibility refers to use of a variety of feedstocks (biomass and fossil origin). In electricity, flexibility is high if different fuel sources can be used for each category of electrical technology.

## 6. Grid-Connected and Grid-Independent

Some fuels and electrical technologies may be either grid-connected or local, and not connected. If a fuel is normally distributed through central systems (pipelines and distribution), it is rated (Y) for grid-connected. In electrical systems, all the technologies can be grid-connected, but for grid independence, some are rated (E) for ease in isolated operation. Some systems are more difficult to operate outside the grid. However, all electrical systems can be designed for local operation, independent of central grids.

## 7. Local Fuels and Feedstocks

These fuels and sources for electrical power are rated (Y/N) for electricity, based on local availability. For fuels, use of locally available feedstocks is rated (L-H) low-high.

## 8. Site Limited and Site Dependent

Site dependent fuels require large fuel stocks and capital investment, as opposed to non-site dependent sources such as Low Btu gas, which can be made in a mobile gasifier transported to dispersed locations. Site dependent electrical technologies such as geothermal or wind are not flexible, like cogeneration systems.

## 9. Local and Regional Components

This refers to the availability of key components and spare parts of technologies which may be found either locally or within the region where the fuel/electrical process is located. As an example, the production of methanol requires a catalyst material usually not available locally. Likewise, small fossil plants require sophisticated components and spare parts that would not be available locally.

## 10. Local Maintenance

Some fuels and technologies can be produced and operated using the local/regional labor force. The ratings are based on the likelihood of availability of this expertise.

## 11. Capital Intensive

Capital intensity refers to the range of installed costs and the strategic material intensity of the fuel processes and technologies. As can be seen, the production and use of dispersed Low Btu gas is one of the highest rated dispersed fuels and technologies.



## 12. Short Lead Time

In general, this refers to fuel processes and technologies which can be ordered and delivered for energy production within three years. Gasoline and SNG facilities require many years to license and construct, as opposed to Low Btu gas facilities which can be built quickly. Likewise, micro-cogeneration systems can be built quickly, unlike geothermal or solar thermal facilities, which require years.

## 13. Mobility

This refers to fuels in cases where the production facility can be located at the source of the fuel. In electricity, mobility refers to the flexibility of the power plant's location. Some technologies, such as small hydro, are definitely not transferable from specific sites.

## 14. Operation and Maintenance Costs

These costs are rated H-L. Maintenance is self-explanatory; operations costs also include labor, capital depreciation, feedstocks and costs of transportation.

## 15. Storage (Fuels)

Storage capability is rated high if storage facilities are locally available, and if it makes sense to store the fuel. Hydrogen, for example, is rated low because it is difficult and expensive to store for an appreciable length of time.

## 16. End Use Flexibility (Fuels)

A fuel is considered to have a high flexibility if many different converters can be adapted to use of the fuel (boilers, turbines, internal combustion engines). Obviously, fuels such as gasoline have high flexibility.

## 17. Scale (Fuels)

The scale of production for fuels is rated L (large) for production processes which are greater than 3,000 tons/day (2.7 million kg) equivalent, M (medium) for processes operating at 1,000-3,000 tons/day (.9-2.7 million kg) equivalent, and S (small) for processes less than 1,000 tons/day (.9 million kg) equivalent.

## 18. Size Range (Electricity)

The size of average technologies and processes is expressed in MW (one megawatt = 1,000 kw); photovoltaics, for example, are used in an average configuration of panels that are small (a few kilowatts), but can be up to ten MW in power "farms." The same is true for wind generation.



19. Intermittent (Electricity)

This refers to technologies which may be seasonal in nature, such as small hydro, or operate only during sunlight (solar systems), thereby requiring energy storage for baseload operation.

20. Costs

Fuel costs are expressed in current dollars/million Btus for fuels at the refinery gate or production site. These costs include amortization of capital investments. Electricity costs are expressed in capital costs per installed kilowatt of capacity (\$/kw). These costs represent current costs, not estimates of future costs of the technologies.

These matrices are designed to be used by local, regional and national planners concerned with the local and regional implementation of decentralized, dispersed and renewable fuels and electric technologies. Prior civil defense studies of the energy system and local recovery characteristics encourage the development of training programs and early implementation of measures which will later become important in an emergency situation. We concur in this generic observation found in prior studies.

The Federal Emergency Management Agency (FEMA) is empowered to consider an attempt to mitigate the potential effects of a number of crisis situations ranging from hurricanes, earthquakes, and nuclear power emergencies to nuclear war. In almost all cases, an effective local and regional approach to dispersal and decentralization of energy sources will serve immediately and in the long range to mitigate effects of disruptions of central resource supply systems.

In addition to FEMA's responsibilities in the energy area, there are similar charges to other federal agencies, including the Department of Energy (DOE) and the Department of Transportation (DOT). The Emergency Energy Conservation Act (EECA) enacted in November 1979 created a framework for a national response to future energy supply interruptions. Title I establishes the basis for standby gasoline rationing to be implemented in the event of a twenty percent shortage of gasoline. Title II creates a federal-state system for dealing with severe, but lesser, shortages through voluntary and mandatory demand restraint or emergency conservation measures.

Title II of EECA authorizes the President to determine that the nation is faced with a severe energy supply interruption or that a severe interruption is imminent. In the event of such a finding, the President may establish national and state-by-state monthly emergency conservation targets for any fuels or energy sources affected by the interruption. Within 45 days after the establishment of emergency targets, the state governors are required to submit plans to the Secretary of Energy indicating the approach the states will take in meeting these targets.

As long as a state meets its targets, it would continue to implement its plan. However, if the President finds that a state is not substantially meeting its targets, and it is unlikely that they will be met, he may, after consultation with the governor, invoke any or all parts of a standby federal plan within the state. A state plan may incorporate virtually any measures which the governor finds suitable, subject to the approval of the Secretary of Energy, and may include measures contained in the standby federal plan.

In order to fully implement this federal conservation plan, DOE is considering the utilization of renewable fuels to meet petroleum shortages. The matrix developed by this Project indicates that local ethanol production facilities offer an available opportunity to increase self-reliance; this is one example of its use. Through effective coordination, local agencies can evaluate a range of energy measures which can reduce vulnerability and contribute to national security. On a national level, there is a demonstrated need for use of this information by FEMA, DOE and DOT (in addition to other federal groups). A coordinated federal effort would be helpful to local communities. The conclusions of this report suggest a mechanism to accomplish this.

## Conclusions and Recommendations (4.4)

The Energy and Defense Project has identified and ranked available dispersed, decentralized and renewable energy resources and technologies that can be utilized on a local and regional basis to enhance security and meet community needs in time of crisis. In order to initiate local, regional and national programs, a process for implementation should be identified and established within FEMA (acting in concert with other federal agencies).

Alternative energy technologies exist, and are commercially available for a wide variety of local and regional uses. However, no comprehensive programs exist to encourage their use for purposes of reducing national vulnerability, increasing self-reliance, and providing a local resource base in time of crisis.

Table 4.4-1 summarizes the recommendations of the Energy and Defense Project. This table is based on developing local and regional programs to (a) inventory energy resources within regions, and (b) implement available dispersed, decentralized and renewable technologies.

To initiate such programs on a local level, we suggest the creation of local/regional entities called "Defense Energy Districts" (DEDs), which would be administratively responsible for categorizing, inventorying, and coordinating the implementation of dispersed, decentralized and renewable energy resources technologies.

At present, the authority for emergency energy planning is split between a number of federal agencies (FEMA, DOE, DOT, etc.) on the national level and a wide variety of state and local agencies. As prior civil defense studies have shown, an essential need in emergency planning is developing data and workable plans well ahead of anticipated crises. The United States is facing a series of potential crises in supply of imported energy and materials at the present time, yet no coordinated effort has been developed to implement local and regional technologies and plans to counter this vulnerability.\* In fact, the existence of many uncoordinated federal programs may hinder the development of local self-sufficiency, rather than assist it.

Funding of DEDs need not be centralized in any one federal, state or local agency. Already established programs under a number of state and federal laws are in existence and provide funding for a range of conservation and alternative energy technologies and programs.

The responsibilities of Defense Energy Districts would include the following:

1. Conduct a complete local inventory of locally and regionally available alternate fuel sources, energy technologies, and energy conversion equipment (motors, cogeneration systems, power facilities, prime movers, critical components supplies, and necessary skills and personnel who have them).

Table 4.4-126

NATIONAL ACTIONS AND POLICIES TO  
ENHANCE REGIONAL ENERGY SECURITY

1980 - 1985

1. Conduct a national inventory of regional dispersed energy sources, fuels and technologies.
2. Integrate this inventory and consolidate energy planning into existing civil defense policies and plans.
3. Identify priority needs for energy supplies and technologies within regions (such priorities should be coordinated with needs for food, communication, other resources).
4. Identify and establish "Defense Energy Districts" within regions, based on energy inventory and priority energy needs criteria.
5. Within DEDs, accelerate implementation of federal, local, and state actions to increase energy conservation (to reduce overall demand) and promote widespread use of dispersed, renewable energy sources and technologies.
6. Establish regional demonstration programs for community energy systems. Establish stockpile and purchase program within regions for high-ranked, commercially available, dispersed energy technologies.
7. Accelerate R&D for all dispersed technologies and integrate purchase programs with ongoing government commercialization efforts.

1985 - 1990

1. Act on initial studies and demonstration programs to make programs available to all DEDs, including stockpiles and available technologies.
2. Accelerate demonstration programs to include all regions.
3. Bring more dispersed energy technologies into mass production; as this occurs, add to local stockpiles and programs.
4. Provide additional incentives and policies to fund DEDs for energy assistance efforts. Such incentives and policies would include acceleration of DOD purchase program for photovoltaics to local governments (and extension of program to include other dispersed energy sources).

2. Identify priority uses in event of crisis or central system disruption and conduct local training programs for use of existing alternate facilities and equipment.
3. Coordinate available funding and develop stockpiles of key energy components, fuel storages, parts and alternate equipment which would be needed in an emergency.
4. Serve as a local coordinating agency for federal emergency energy contingency programs. This would help eliminate wasteful, redundant current programs, and would improve local capability of response to a crisis (petroleum shortages, system disruptions, etc.).

---

\*The Energy Security Act, Title IV, provides for a short-term analysis of demonstrating "self-sufficiency in one or more states" within the next three years. This could be the starting point for a more unified national energy strategy in the interests of national security.

Already, many available alternative technologies are available which can be immediately implemented on the community level to provide dependable alternate fuel and power in time of crisis. In the field of emergency communications alone, photovoltaic technology provides a range of dependable power back-up for voice and data telecommunications equipment, emergency transmitters, field radios, distribution system equipment and various signal devices. This equipment can be purchased now by local and regional organizations concerned with emergency energy contingency planning. A new study for the Department of Energy, performed by Science Applications, Inc., points out that photovoltaic, wind and solar thermal systems will be available on a full commercial basis for the institutional market within five years. Table 4.4-2 compares the commercial readiness of these alternative energy technologies.

Table 4.4-2<sup>27</sup>

DISPERSED USER SOLAR ELECTRIC TECHNOLOGY OPTIONS

Technology	Appropriate scale (kWp)	Rating of case analyzed (kWp)	Year of commercial readiness for each market segment				
			Residential	Commercial	Institutional	Industrial	Agricultural
<b>Photovoltaics</b>							
• small flat panel	15-50	10	1985	1985			1985
• intermediate flat panel	50-5000	100		1985	1985	1985	1985
• intermediate line focus	50-5000	100		1985	1985	1985	1985
<b>Solar thermal</b>							
• dish organic Rankine	22-2200	220		1990	1990	1990	1990
<b>Wind</b>							
• small horizontal axis	15-40	10	1985	1985			1985
• small vertical axis	15-30	10	1990				1990
• intermediate horizontal axis	200-1500	300		1985	1985	1985	1985
• intermediate vertical axis	200-500	220		1985	1985	1985	1985



Many other technologies identified in this study are commercially available today and offer great potential in energy contingency planning. An example is load management technology, which can meet both the needs of energy conservation on a dispersed basis and also meet the needs of emergency communication. Remote devices connected to residences, commercial enterprises, public agencies and industries can accomplish load control as well as two-way communications. Such equipment is available today and tests are being performed by a number of electric utilities. An immediate use for such technologies is coordination of FEMA nuclear plant safety evacuation planning with remote load management devices designed for emergency communications. Thus, energy demand can be reduced simultaneously with the development of modern contingency communications technology.

Use of available alternative technologies by local and regional organizations is an important tool in energy emergency planning. The evaluation methodology (i.e., the fuels and electricity matrices) developed can be adapted for use by local and regional organizations.

### Summary

The Energy and Defense Project has evaluated a number of dispersed, decentralized and renewable energy sources which offer a potential for reducing of national vulnerability (energy, resources, materials, war), increasing the self-sufficiency of local communities, and strengthening national security.

Recognition of the strategic value of policies to implement local and regional energy decentralization and increase deployment of renewable sources is a primary consideration and conclusion of this study. In summary, the major findings are:

- Current U.S. energy systems (fuels and electricity) are highly vulnerable, due to requirements for imported resources and due to the centralized nature of the systems themselves.
- Dispersed, decentralized and renewable energy sources can reduce national vulnerability and the likelihood of war by substituting for vulnerable centralized resources.
- National policies and goals need to be developed to strengthen current inadequate energy emergency contingency planning and incorporate decentralized and renewable energy sources in planning.
- Local policies and goals need to be developed to implement the range of programs described in the concept of the Defense Energy District.

- National energy self-sufficiency programs (including synfuel development and the Strategic Petroleum Reserve) are highly centralized, thus highly vulnerable. A better strategic opportunity is the development of dispersed local and regional approaches.
- Current funding levels (both private and public) for decentralized and renewable energy are inadequate. National priorities should reflect the strategic value and importance of the decentralist/renewable energy opportunity.

## SECTION 4

### DISPERSED ENERGY SOURCES AND COMMUNITY SURVIVAL

#### FOOTNOTES

1. Civil Defense for the 1980's--Current Issues, Defense Civil Preparedness Agency, Washington, D.C., July 13, 1979, p. 35.
2. Garwin, Richard L., letter to Representative John Seiberling, February 4, 1980.
3. Calder, Nigel, Nuclear Nightmares, An Investigation into Possible Wars, Viking Press: New York, N.Y., 1980, p. 155.
4. Ibid.
5. Van Horn, W.H., G. Boyd, and C.R. Foget, Repair and Reclamation of Gas and Electric Utility Systems, URS Corporation, Burlingame, Ca., July, 1967.
6. Foget, C., W.H. Van Horn, Availability and Use of Emergency Power Sources in the Early Postattack Period, URS Research Corporation, Burlingame, Ca., August, 1969.
7. Black, R.H., Improvising Electric Power from Induction Generators During Prolonged Power Outages, URS Research Corporation, San Mateo, Ca., September, 1971.
8. Foget and Van Horn, op. cit.
9. Ibid.
10. Figure 4.2-1, "Conversion of Truck Engine to Induction Motor," Source: Black, op. cit.
11. Figure 4.2-2, "Schematic of Load Connections," Source: Ibid.
12. Ibid.
13. Calder, op. cit., p. 102.
14. Aviation Week and Space Technology, October 6, 1980, p. 27.
15. Stanek, E.K., Feasibility of Isolating Vulnerable Equipment of the Electric Power System from Sources of EMP, U.S. Department of Energy, ERA, March, 1978.
16. Ibid.

FOOTNOTES (Continued)

17. Figure 4.2-3, "Area of Coverage of EMP From High Altitude Detonations," Source: Ibid..
18. Ibid., p. 30.
19. Ibid., 33-34.
20. Ibid., 33-34.
21. Morable, J., P. Barnes, and D. Nelson, Power System EMP Protection, Oak Ridge National Laboratory, Oak Ridge, Te., March, 1975.
22. Stanek, op. cit., p. 36.
23. Telephone interviews, September 1980, SRI, International EMP Group; Solarex Corporation; Monegon Corporation; and others.
24. Figure 4.3-1, "Fuels Matrix," Source: Energy and Defense Project, developed at Technical Conference, Asilomar, Ca., September 18-21, 1980.
25. Figure 4.3-2, "Dispersed Electricity Matrix," Source: Ibid.
26. Table 4.4-1, "National Actions and Policies to Enhance Regional Energy Security," Source: Ibid.
27. "Regional Study Shows Significant Potential for Solar Electric Power," Solar Engineering, September, 1980, p. 16.

## DISTRIBUTION LIST

// Copies

<u>Organization</u>	<u>#Copies</u>	<u>Organization</u>
Federal Emergency Management Agency Litigation and Research Attn: Administrative Officer Washington, D.C. 20472	60	The Dikewood Corporation 1613 University Blvd., N.E. Albuquerque, NM 87102
Defense Technical Information Center Hampton Station Alexandria, VA 22314	12	Ohio State University Disaster Research Center 128 Derby 154 North Oval Mall Columbus, OH 43210
Civil Defense Research Project Oak Ridge National Laboratory Attn: Librarian Box X Oak Ridge, TN 37830	1	Dr. Gerald Klomglaan Dept. of Sociology & Anthropology Iowa State University Ames, IA 50010
Dr. William W. Chenault Human Sciences Research, Inc. Westgate Research Park 710 Old Springhouse Road McLean VA 22101	1	General Leslie Bray Suite 1200 8301 Greensboro Drive McLean, VA 22102
Dr. Jiri Nehnevajsa Professor of Sociology University of Pittsburgh Pittsburg, PA 15213	1	Mr. Howard McClennon, President Int'l Association of Fire Fighters 1750 New York Avenue, N.W., 3rd F. Washington, D.C. 20006
Dr. Conrad Chester RDA, Holifield Nat'l Laboratory O. Box X Oak Ridge, TN 37890	1	General Manager Int'l Association of Fire Chiefs 1329-18th Street, N.W. Washington, D.C. 20036
Dr. Walmer E. Strobe Center for Planning and Research 100 Columbia Pike Hillery Cross-Roads, VA 22041	1	Mr. Bjorn Pedersen Int'l Association of Chiefs of Police 11 Firstfield Road Gaithersburg, MD 20760
Dr. Don Johnston Research Triangle Institute O. Box 12194 Research Triangle Park, NC 27709	1	Mr. Ferris Lucas National Sheriff's Association 1250 Connecticut Ave., N.W., #300 Washington, D.C. 20036
Dr. Richard K. Laurino Center for Planning and Research, Inc. 33 East Bayshore Road Berkeley, CA 94303	1	Mr. Gerald W. Collins, Exec. V.P. National Defense Transportation Assn 1612 K Street, N.W., Suite 706 Washington, D.C. 20006
National Fire Protection Association Attn: Library 1 Atlantic Avenue Boston, MA 02210	1	Mr. Robert Harker SYSTAN, Inc. 343 Second Street P.O. Box U Los Altos, CA 94022

1

1

1

1

1

1

1

1

1

1

1

<u>Organization</u>	<u>#Copies</u>	<u>Organization</u>	<u>#Copies</u>
National Bureau of Standards Master Research Coordinator Attn: Mr. C.G. Culver Office of Federal Building Technology Center for Building Technology Washington, D.C. 20234	1	Mr. Marie Hayman International City Management Assn. 1140 Connecticut Ave., N.W. Washington, D.C. 20036	1
Command and Control Technical Center The Pentagon - BE 685 Washington, D.C. 20301	1	Ms. Clara Rubin Academy of Contemporary Problems 1501 Neil Avenue Columbus, Ohio 43201	1
Dr. Louis V. Spencer Radiation Theory Section National Bureau of Standards 4325, Room C-313 Washington, D.C. 20418	1	Mr. Cliff McLain System Planning Corporation 1500 Wilson Boulevard Suite 1500 Arlington, VA 22209	1
National Academy of Sciences (JH-312) Commission on Sociotechnical Systems SEP 11 Constitution Avenue, N.W. Washington, D.C. 20418	1	Dr. John R. Christiansen Department of Sociology 183 Faculty Office Bldg. Brigham Young University Provo, UT 84601	1
Dr. Leo A. Hoegh 10000 W. 10th Avenue Golden, CO 80811	1	Dr. Abner Sachs Science Applications, Inc. 1651 Old Meadow Road, #620 McLean, VA 22101	1
State Council of State Governments Attn: Mr. Hubert A. Gallagher Master Assistance Project 15 Connecticut Avenue, N.W., #300 Washington, D.C. 20036	1	Stanford Research Institute Attn: Librarian 333 Ravenswood Avenue Menlo Park, CA 94025	1
Dr. Joseph E. Minor Texas Tech University Department of Civil Engineering P.O. Box 4089 Lubbock, TX 79409	1	Dr. John W. Billheimer SYSTAN, Inc. 343 Second Street P.O. Box U Los Altos, CA 94022	1
Assistant Secretary of the Army (R&D) ATTN: Assistant for Research Washington, D.C. 20301	1	Chief of Naval Research Washington, D.C. 20301	1
Rockwell International National Laboratory ATTN: Librarian P.O. Box X Rockwell, TN 37830	1	Mr. Phillip M. Smith Associate Director, Natural Resources and Commercial Services Office of Science and Technology Policy Executive Office Building Washington, D.C. 20500	1
Los Alamos Scientific Laboratory ATTN: Document Library Los Alamos, N.M. 87544	1	The RAND Corporation ATTN: Document Library 1700 Main Street Santa Monica, CA 90401	1



DISPERSED, DECENTRALIZED AND RENEWABLE ENERGY SOURCES: ALTERNATIVES TO NATIONAL VULNERABILITY AND WAR, Unclassified

Energy & Defense Project, DCPA Contract 01-79-C-0320

Sections 1 & 2 of this report contain background information on centralized energy systems and the relationship between vulnerability of these systems, energy planning, and existing civil defense programs.

Sections 3 & 4 contain an extensive investigation, review and categorization of alternative approaches to centralized, vulnerable energy systems; a review of dispersed and renewable technologies which can be appropriately implemented at the local level; and matrices for evaluation of these technologies for emergency and crisis planning. Specific recommendations to the Federal Emergency Management Agency are included on the use of localized energy approaches for emergency response and recovery situations.

FEMA Work Unit #2314-F

340 pages

DISPERSED, DECENTRALIZED AND RENEWABLE ENERGY SOURCES: ALTERNATIVES TO NATIONAL VULNERABILITY AND WAR, Unclassified

Energy & Defense Project, DCPA Contract 01-79-C-0320

Sections 1 & 2 of this report contain background information on centralized energy systems and the relationship between vulnerability of these systems, energy planning, and existing civil defense programs.

Sections 3 & 4 contain an extensive investigation, review and categorization of alternative approaches to centralized, vulnerable energy systems; a review of dispersed and renewable technologies which can be appropriately implemented at the local level; and matrices for evaluation of these technologies for emergency and crisis planning. Specific recommendations to the Federal Emergency Management Agency are included on the use of localized energy approaches for emergency response and recovery situations.

DISPERSED, DECENTRALIZED AND RENEWABLE ENERGY SOURCES: ALTERNATIVES TO NATIONAL VULNERABILITY AND WAR, Unclassified

Energy & Defense Project, DCPA Contract 01-79-C-0320

Sections 1 & 2 of this report contain background information on centralized energy systems and the relationship between vulnerability of these systems, energy planning, and existing civil defense programs.

Sections 3 & 4 contain an extensive investigation, review and categorization of alternative approaches to centralized, vulnerable energy systems; a review of dispersed and renewable technologies which can be appropriately implemented at the local level; and matrices for evaluation of these technologies for emergency and crisis planning. Specific recommendations to the Federal Emergency Management Agency are included on the use of localized energy approaches for emergency response and recovery situations.

FEMA Work Unit #2314-F

340 pages

DISPERSED, DECENTRALIZED AND RENEWABLE ENERGY SOURCES: ALTERNATIVES TO NATIONAL VULNERABILITY AND WAR, Unclassified

Energy & Defense Project, DCPA Contract 01-79-C-0320

Sections 1 & 2 of this report contain background information on centralized energy systems and the relationship between vulnerability of these systems, energy planning, and existing civil defense programs.

Sections 3 & 4 contain an extensive investigation, review and categorization of alternative approaches to centralized, vulnerable energy systems; a review of dispersed and renewable technologies which can be appropriately implemented at the local level; and matrices for evaluation of these technologies for emergency and crisis planning. Specific recommendations to the Federal Emergency Management Agency are included on the use of localized energy approaches for emergency response and recovery situations.